

OUC 40425



**US Army Corps
of Engineers**

Interagency Expanded Site Investigation

**Evaluation of White Phosphorus
Contamination and Potential Treatability
at Eagle River Flats, Alaska**

FY 98 Report



**Cold Regions Research and
Engineering Laboratory**
72 Lyme Road • Hanover • New Hampshire 03755

**INTERAGENCY EXPANDED SITE INVESTIGATION:
EVALUATION OF WHITE PHOSPHORUS CONTAMINATION
AND POTENTIAL TREATABILITY AT EAGLE RIVER FLATS, ALASKA**

FY 98 REPORT

July 1999

**INTERAGENCY EXPANDED SITE INVESTIGATION:
EVALUATION OF WHITE PHOSPHORUS CONTAMINATION
AND POTENTIAL TREATABILITY AT EAGLE RIVER FLATS, ALASKA**

FY 98 REPORT

July 1999

Prepared for

U.S. ARMY, ALASKA
DIRECTORATE OF PUBLIC WORKS
William A. Gossweiler, Remedial Project Manager
and
U.S. ARMY ENGINEER DISTRICT, ALASKA
JoAnn T. Walls, Project Engineer

Prepared by

U.S. ARMY COLD REGIONS RESEARCH AND ENGINEERING LABORATORY
Charles M. Collins and Mark J. Hardenberg, Report Editors

CONTRIBUTORS

M.E. Walsh, C.H. Racine, C.M. Collins, M.R. Walsh, E.F. Chacho, R.N. Bailey, D.J. Lambert,
B. Tracy, P. Berger
U.S. Army Cold Regions Research and Engineering Laboratory

J.L. Cummings, R.E. Johnson, K.S. Gruver, P.A. Pochop, D.L. York, J.E. Davis, J.B. Bourassa
U.S. Department of Agriculture, National Wildlife Research Center, Fort Collins, CO

D.G. Robertson
WEST, Inc.

W.D. Eldridge
U.S. Fish and Wildlife Service, Division of Migratory Bird Management, Anchorage, AK

Points of Contact:

W.A. Gossweiler
Director of Public Works
600 Richardson Drive #6500
ATTN: APVR-PW-ENV
Fort Richardson, Alaska 99505
(907) 384-3017
(907) 384-3047 Fax

Charles M. Collins
CRREL
72 Lyme Road
Hanover, NH 03755
(907) 353-5180
(907) 353- 5142 Fax

TABLE OF CONTENTS

I. EXECUTIVE SUMMARY	1
 II. RISK ASSESSMENT	
II-1. Waterbird Utilization of Eagle River Flats: April–October 1998 <i>William D. Eldridge, and Donna G. Robertson</i>	7
II-2. Movements, Distribution, and Relative Risk of Waterfowl Using Eagle River Flats: 1998 <i>John L. Cummings, Richard E. Johnson, Kenneth S. Gruver, Patricia A. Pochop, Darryl L. York, James E. Davis, Jean B. Bourassa, and Charles H. Racine</i>	19
 III. TREATABILITY STUDIES	
III-1. Eagle River Flats Pond Pumping Treatability Study: Full-Scale Deployment of Remote Pumping Systems <i>Michael R. Walsh, Charles M. Collins, and Dennis J. Lambert</i>	31
III-2. Treatment Verification: Monitoring the Remediation of White Phosphorus Contaminated Sediments of Drained Ponds <i>Marianne E. Walsh, Charles M. Collins, and Ronald N. Bailey</i>	57
III-3. Weather Data for Eagle River Flats <i>Charles M. Collins</i>	99
 IV. EAGLE RIVER FLATS SPATIAL DATABASE	
IV-1. Monitoring Physical and Biological Changes in Eagle River Flats <i>Charles H. Racine, Edward F. Chacho, Brian Tracy, and Peter Berger</i>	109
IV-2. Database for Monitoring Remediation Efforts and Success at Eagle River Flats <i>Charles H. Racine and Peter Berger</i>	121

I. EXECUTIVE SUMMARY

INTRODUCTION

This is the ninth annual contract report prepared by researchers from CRREL and other Federal agencies for U.S. Army Engineer District, Alaska, and U.S. Army Alaska–Public Works, describing the results of white phosphorus contamination studies in Eagle River Flats, an 865-ha estuarine salt marsh on Fort Richardson, Alaska. Fort Richardson is on the National Priority List and Eagle River Flats is designated as part of Operable Unit C (OU-C) under the *Comprehensive Environmental Response, Compensation, and Liability Act* (CERCLA). Documents produced under CERCLA, such as the Ecological Risk Assessment, Remedial Investigation Report, Feasibility Study Report, the Proposed Plan, and the Record of Decision, have used the research results first published in this series of annual contract reports.

Of special interest in this year's report is the full-scale treatability study using six remote-controlled pumps to temporarily drain contaminated ponds within several areas of Eagle River Flats. The pumps keep the ponds drained for an extended period during the summer, thus allowing the pond bottom sediments to dry and the white phosphorus to sublime and oxidize. This treatability study expanded on the study conducted last year, when we first used a 2000-gal./min pump in Pond 183 in Area C. That study was highly successful, exceeding our most optimistic expectation. This year we deployed five additional pumps and generators to several pond locations. As part of the treatability study, we had to work out the logistics of deploying, refueling, monitoring, and recovering these systems from remote sites within Eagle River Flats. The success of the pumping treatability studies resulted in pond pumping being chosen as the preferred alternative in the Record of Decision for OU-C, signed in October 1998.

Despite a very cool and rainy summer, the pond pumping resulted in significant sediment drying and loss of white phosphorus in treated ponds. Composite sampling of the pond bottom sediments before and after treatment showed a reduction of over 50% in the average white phosphorus concentration levels in Pond 183 and lesser levels in other locations. Other studies reported on this year are the waterfowl use and mortality studies, the monitoring of reduction of white phosphorus contamination in the various treatability study areas, monitoring of drained pond habitats, and associated vegetation and erosional changes, and the management of all the data collected for Eagle River Flats in the ERF GIS database.

II-1. WATERBIRD UTILIZATION OF EAGLE RIVER FLATS: APRIL–OCTOBER 1998

William D. Eldridge and Donna G. Robertson

The U.S. Fish and Wildlife Service conducted 36 aerial surveys of waterbirds at Eagle River Flats (ERF) from April through October 1998 as part of the on-going waterbird mortality and monitoring program sponsored by the U.S. Army at Fort Richardson. Fixed-wing airplanes obtained complete coverage of ERF during all surveys. Waterbirds were counted by species or species groups and classified in standardized study areas and individual ponds, when possible.

ERF experienced an early spring breakup, a wet summer, and a normal fall, with a final freezeup in late October. Migration phenology was within the normal range, and species composition of waterbirds was similar to previous years. Mean spring and fall use by swans was below the long-term average. Areas A and B were important to swans in the spring, but Areas B and D were most important in fall. Ponds of Areas B, CD, and D were important to ducks in spring and fall, and the tide flats of Coastal East and West also were important to ducks in the fall. Fall use by ducks was 28% below the long-term average. Areas CD and B had the highest densities of ducks on ponded areas in the fall.

There were important changes in fall use of ERF between 1997 and 1998. A 62% reduction in use of Area A occurred in 1998, with a 100% reduction in use of Pond 290, which was drained by pumping this year. Area C also saw decreased use. Area CD experienced a 34% increase in use, and Coastal East and West also experienced more use, primarily from ducks loafing on the tideline. It appears that the goal of moving ducks from Areas A and C to other areas of ERF is succeeding. What is not clear is the white phosphorus contamination levels of some of the areas where increased duck use is occurring.

II-2. MOVEMENTS, DISTRIBUTION, AND RELATIVE RISK OF WATERFOWL USING EAGLE RIVER FLATS: 1998

John L. Cummings, Richard E. Johnson, Kenneth S. Gruver,
Patricia A. Pochop, Darryl L. York, James E. Davis,
Jean B. Bourassa, and Charles H. Racine

We determined spatial distribution, movements, turnover rate, and mortality of mallards using Eagle River Flats, Fort Richardson, Alaska, during fall migration, 4 August to 22 October 1998. Using a net-gun from a Bell 212 helicopter, we randomly captured 109 mallards between 4 and 13 August on ERF. Each mallard was banded and fitted with a 9.1-g backpack transmitter and released at its capture site. Of the 109 mallards, 60 were fitted with standard transmitters and 49 were fitted with mortality transmitters. Tracking data indicated that transmitters did not appear to inhibit mallard movements or activities. LOCATE II was used to map telemetry locations. Mallard movements and distribution indicate that they spent about 75% of their time in Areas A, B, C, and C/D. In addition, mallards spent about 65% of their time in areas that are considered contaminated (A, Bread Truck, C, C/D, and Racine Island). The average daily turnover rate for waterfowl

was about 1.3%. The greatest turnover of waterfowl occurred from 12–19 August and from 13–16 October, when 24% and 54% of the mallards, respectively, departed ERF. Mortality of instrumented mallards that used ERF from 4 August to 22 October was 33. Of those, 29 were attributed to white phosphorus ingestion. The greatest mortality occurred in Area C/D, with 12 of 29 (41%); Area A, with 5 of 29 (17%); and Area C, with 5 of 29 (17%). Overall, these areas accounted for 82% of the mallard mortality on ERF. No mallard mortality was noted from capture, handling, or the transmitter. We recovered 13 whole duck bodies from the 29 white phosphorus mortalities. Analysis showed 10 were positive for WP. A mortality model was developed for ERF to estimate the total individual dabblers using ERF, the peak number of dabblers using ERF, and the total number of duck mortalities on ERF during the fall migration period. In 1996, 5413 individual dabblers used ERF from 3 August to 16 October, peaking at 2333 between 13 and 16 September. The overall mortality of dabblers was 655. In 1997, 6063 individuals dabblers used ERF from 2 August to 22 October, peaking at 4398 between 9 and 10 September. The overall mortality of dabblers was 240. In 1998, 3722 individual dabblers used ERF from 4 August to 22 October, peaking at 1583 between 27 August and 2 September. The overall mortality of dabblers was 355. These data represent a minimum number of mortalities on ERF during the fall migration. In conclusion, we feel that the baseline data collected in 1996, 1997, and 1998 can be used to measure the effects of future remediation actions.

III-1. EAGLE RIVER FLATS POND PUMPING TREATABILITY STUDY: FULL-SCALE DEPLOYMENT OF REMOTE PUMPING SYSTEMS

Michael R. Walsh, Charles M. Collins, and Dennis J. Lambert

The success of the first deployment of a remote pumping system in Pond 183, Area C, of Eagle River Flats, indicated that this may be the best remediation method for the white phosphorus contamination in permanent ponds. To determine if this method is feasible under different operating parameters, six pump systems were deployed in 1998. Of these, four were installed at previously prepared sites in May and two were installed in newly prepared sites at the end of June. In May, the pump system deployed earlier in Pond 183 was returned, along with a smaller pump in the adjacent Pond 155 and a large capacity tandem pump in a dredged area of Pond 146. These three pump systems worked together to pump down Area C after a flooding event. The system in Pond 146 is shore-based, while the system in Pond 155 is remote but easily accessible. An additional pump system was placed in Pond 290 in Area A, a remote site across the Eagle River, to help develop logistical procedures for the deployment of additional remote systems in that area. Four tide gates were installed in Area C to try to extend the period between flooding tides.

In late June, sumps were blown in Ponds 256 and 258, Area A. Pump systems were installed at those sites and all were refueled using Blackhawk helicopters and double-walled fuel tanks. Logic errors in the controls were corrected at this time, and all systems were fully operational at the end of the month.

In August, drainage ditches were blasted using detonation cord, a quick and safe method for enhancing drainage in the ponds. The equipment was shut down in late August and retrograded by the end of the first week of September, prior to the flooding tide. Deployment and retrograde procedures have been developed to minimize the amount of helicopter time required. A total of only 2.5 hours was required to retrograde five pump systems and two fuel tanks in the fall.

Results of the 1998 field season are generally good. Poor weather inhibited drying throughout the normally dry months of May and June. A fuel spill near Pond 146 shut that system down for over two weeks. Only one tide defeated the tide gates all summer, but the area was easily pumped out over the course of a day. The remote fuelling operations ran much smoother than anticipated, and three more tanks have been acquired for future operations. Some site work still needs to be done before deployment next spring, with a sump in Pond 146 being the major task. Overall, 8.7 ha of permanent ponds and 10 ha of adjacent mudflats were addressed this year.

III-2. TREATMENT VERIFICATION: MONITORING THE REMEDIATION OF WHITE PHOSPHORUS CONTAMINATED SEDIMENTS OF DRAINED PONDS

Marianne E. Walsh, Charles M. Collins, and Ronald N. Bailey

We continued to monitor the effectiveness of pond draining on the remediation of sediments contaminated with white phosphorus by recording sublimation-oxidation conditions and changes in white phosphorus over time. In the drained ponds, we measured: 1) sediment temperature and moisture conditions at hourly intervals using sensors linked to a datalogger; 2) white phosphorus concentrations remaining from past training with white phosphorus munitions; and 3) residual white phosphorus from particles we planted in the surface sediment.

In the main pond of Area C (Pond 183), which was drained by pumping, the sediments were not saturated with water for the last half of June and most of July of 1998 despite frequent precipitation. However, sediment temperatures were lower than in previous years. Nonetheless, all measurements of white phosphorus (concentrations in composite and discrete samples, percentage of positive samples, masses of planted particles) show a reduction in the contamination. Owing to heterogeneity of the size of munitions-derived white phosphorus particles and sediment moisture conditions, a precise rate of decline in mass of white phosphorus is impossible to determine. However, based on data we obtained from repeated sampling in an intermittently flooded pond, complete decontamination of the surface sediment can be attained in 7 years.

Pond 290 of Area A was also drained by pumping as part of a treatability study to demonstrate the feasibility of pumping in a remote location. This pond was identified as a "hot pond" because of the presence of craters, permanent water, and waterfowl. While previous sampling did not indicate widespread contamination with white phosphorus (of the six samples taken, only one sample was positive, a sample collected by CHPPM and the concentration was four times lower than the reported method detection

limit), the pond was sufficiently similar to other contaminated areas to warrant further sampling. Once it was pumped, we intensively sampled the surface sediments. Confirming the results of previous discrete sampling, we did not find widespread white phosphorus contamination; none of the samples we collected had detectable white phosphorus from past Army training. During the summer, the middle of the pond, nearest the pump, dried significantly, resulting in loss of most of the mass of white phosphorus particles we planted. Owing to constant groundwater recharge, drying was less at the north and south ends of the pond, leaving most of the white phosphorus particles we planted 80 m north and south of the sump.

Ponds 258 and 256 of Area A were drained late in the season. We intensively sampled pond 258, and, again confirming previous discrete sampling, we found low concentrations of white phosphorus in just a few samples (3 out of 44 composite samples).

We continued monitoring in Bread Truck Pond, which is drained by ditching. The gully continues to advance from the north into the pond, and the surface sediment surrounding the gully has eroded several centimeters down to an organic layer. The sediments of the north side of the pond dried, and loss of mass of planted white phosphorus particles was greatest adjacent to the gully. Discrete samples taken from locations that had very high white phosphorus concentrations in 1991 were blank when sampled in August 1998. The surface topography of Bread Truck Pond hampers draining, especially from its south side.

Racine Island Pond 297 is still severely contaminated with white phosphorus particles. Additional remedial actions, such as filling, may be needed for this small pond.

III-3. WEATHER DATA FOR EAGLE RIVER FLATS

Charles M. Collins

The meteorological station located on the edge of the EOD pad in Eagle River Flats, originally installed in 1994, was removed, recalibrated, and reinstalled in May 1998. The station ran the entire summer without a problem. It also served as the base station for the relay of data from the remote dataloggers in ERF. Data from those dataloggers were relayed through the base station via radio and mobile phone to a computer server at CRREL. Both the weather data and the soil moisture and temperature data from four remote sites were made available daily on the CRREL web site, allowing researchers to regularly monitor conditions in the Flats even when no one was in the field.

The summer of 1998 was one of the wetter summers on record, with especially heavy rainfall events in late May, June, and August. May and June are normally the driest months of the core drying season needed for treatment of contaminated sediments from the pond bottoms. The late flooding tides of May eliminated any effective drying that month, and June was one of the wettest on record, with over twice the normal rainfall. Precipitation in August was also well above normal. Air temperatures were normal for the last week of May and for June but were below normal for July and August. There were only 18 days during the entire summer when the maxi-

mum air temperature exceeded 20°C. The radiation record indicates that the skies were cloudy for almost the entire 3 months from mid-May through August. Rain fell regularly throughout late May and June. During early August, a large rainfall event occurred on the 5th and 6th, totaling 44 mm (1.74 in). There was another large rain event on the 21st with 10.2 mm (0.41 in).

IV-1. MONITORING PHYSICAL AND BIOLOGICAL CHANGES IN EAGLE RIVER FLATS

Charles H. Racine, Edward F. Chacho, Brian Tracy, and Peter Berger

Methods for monitoring environmental change associated with remediation and natural erosional processes at Eagle River Flats were developed and applied. Both remote sensing and plot monitoring techniques were used to determine habitat change. Aquatic submerged vegetation has been lost from all dewatered (pumped or ditched) ponds. In addition some emergent species, such as four-leaved mare's tail colonies, have died back in a pond pumped for 2 years. Analysis of spectral data from 1995, 1997, and 1998 suggests loss of vegetation cover over a broad area bordering pumped and ditched ponds (183 and 109). In deeper ponds (146 and 155), pumped during summer 1998, there is evidence of vegetation expansion onto the exposed organic sediments of the pond bottom. Headward gully erosion rates of 64 m from 1991 to 1995 and 13 m from 1995 to 1998 were measured on a tidal creek using scanned and georeferenced aerial photos. Good agreement was obtained between remote sensing-GIS and field measured lateral erosion rates from 1995 to 1998 along the same gully section, supporting the use of this method for future erosion monitoring.

IV-2. DATABASE FOR MONITORING REMEDIATION EFFORTS AND SUCCESS AT EAGLE RIVER FLATS

Charles H. Racine and Peter Berger

The Eagle River Flats database currently consists of six libraries containing over 100 GIS coverages, together with about 37 aerial images. The database is useful for evaluating the success of the remediation effort as well as for assessing change in habitat. New additions and revisions of the database made during 1998 are described. These include several methods of white phosphorus sampling, such as composited samples, point samples, and planted particles. Other additions include a pond remediation coverage that tracks ponds where remediation actions are being conducted. Monitoring sites where soil moisture and temperature are measured during the summer are also being added.

II-1. WATERBIRD UTILIZATION OF EAGLE RIVER FLATS: APRIL–OCTOBER 1998

William D. Eldridge
U.S. Fish and Wildlife Service

Donna G. Robertson
WEST, Inc.

INTRODUCTION

Aerial surveys to monitor waterbird use of Eagle River Flats (ERF) during the spring, summer, and fall of 1998 were conducted by the U.S. Fish and Wildlife Service as part of the ongoing mortality and monitoring studies of ERF sponsored by the U.S. Army. The purpose, history, and status of these investigations have been presented elsewhere (Racine and Cate 1996).

STUDY AREA

Eagle River Flats is a salt marsh complex comprising 870 ha located on the southern side of Knik Arm, approximately 10 km east of Anchorage (Fig. II-1-1). A detailed description of this area is presented in Racine and Cate (1996).

METHODS

Aerial surveys of ERF were flown from April through October 1998. Surveys were conducted twice per week during spring and fall and once per week during summer, except when weather or airspace restrictions precluded flights. Surveys were flown using fixed-wing aircraft at an airspeed of 100–120 km/hr and at an altitude of 70–75 m. Total coverage of ERF was obtained by overlapping transects. Numbers of waterbirds were

counted or estimated and recorded by species or species group with a cassette tape recorder. Waterfowl numbers were classified by locations on ERF, using standardized study areas (Fig. II-1-1). When possible, birds were also recorded by individual ponds within the study areas, using a standardized pond numbering system. Areas (ha) of permanent and intermittent study ponds were obtained from digitized maps provided by CRREL and used to convert bird numbers to densities within the study areas.

RESULTS AND DISCUSSION

Moisture conditions

Spring of 1998 was very mild with an early breakup. This created favorable conditions in April throughout Cook Inlet marshes. Cooler weather predominated later in spring, but much of the waterbird habitat was already available. ERF had open habitat much earlier than normal, with 90% of the area ice free by mid-April. Areas A and C/D were nearly completely open in mid-April, while parts of D and B remained frozen. Late April tides flooded most ponds.

Summer of 1998 was wetter than recent years. Water conditions in marshes throughout Cook Inlet were the best they have been in years, and ERF marshes also were wet, except where they were being pumped or drained.

Fall in Cook Inlet was generally mild.

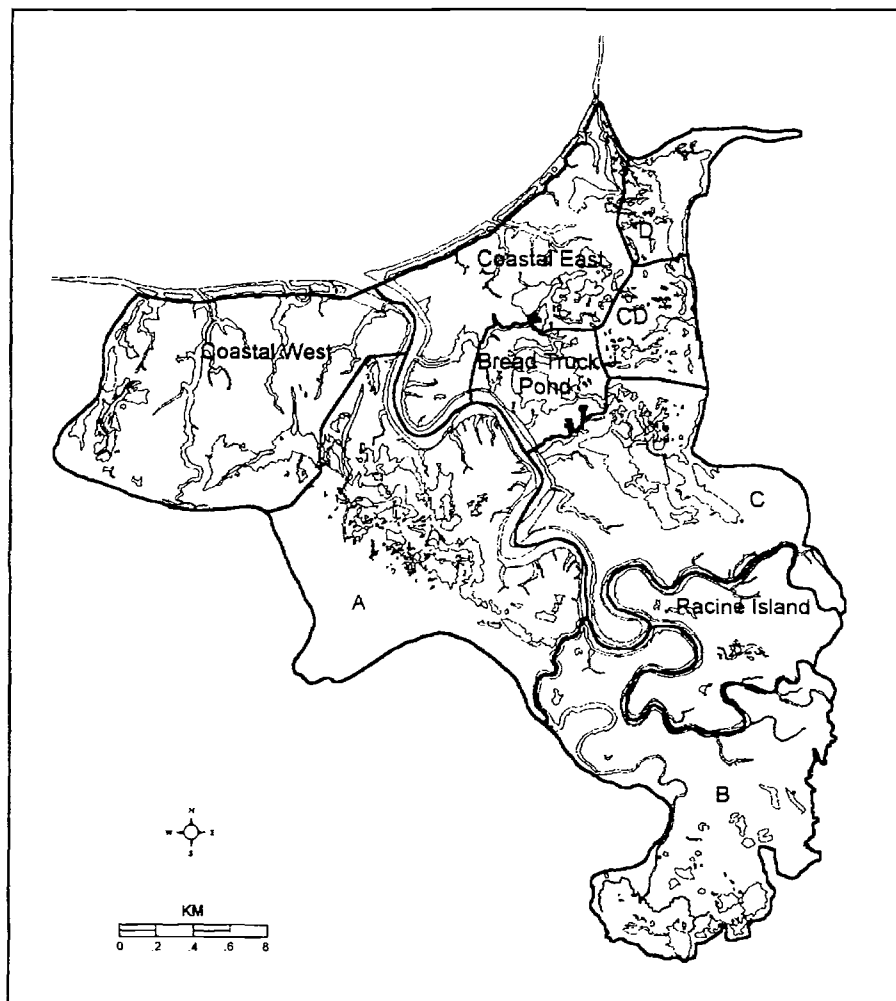

Figure II-1-1. Standardized ERF study areas surveyed for waterfowl.

While some skim ice appeared over most of the ERF ponds on 2 October, it was short-lived and flood tides opened the area within a few days. Regardless of tides, skim ice generally melts in the afternoon at this time of year if temperatures are not extreme. ERF continued to periodically freeze and thaw until 21 October, when 80% of ERF was frozen for good. A few ducks remained in the area when surveys ended on 30 October, utilizing tide sloughs after all ponds had frozen. Elsewhere in Cook Inlet, mild weather combined with favorable tides permitted a significant number of mallards to remain, utilizing coastal mudflats until mid-November.

Abundance and distribution of waterbirds on ERF

In 1998, 36 aerial surveys were conducted. Numbers of birds by species or species groups are listed by survey date in Table II-1-1 and Figure II-1-2. Utilization of ERF study areas by major waterfowl groups by season is presented in Tables II-1-2 and II-1-3. A discussion of utilization of ERF by species or species groups is presented below.

Swans

Tundra (*Columbus columbianus*) and trumpeter swans (*C. buccinator*) utilized ERF in small numbers during spring of 1998, with a

Table II-1-1. Numbers of birds, by species or species group, observed during aerial surveys of ERF in 1998.

	4/15	4/21	4/24	4/28	4/30	5/4	5/6	5/11	5/18	5/21	5/27	6/1	6/12	6/29	7/6	7/14	7/26
Swans	0	12	67	30	5	0	0	2	1	0	0	0	0	0	0	0	0
Geese																	
Greater white-fronted	0	7	2	0	12	5	5	0	0	0	2	0	0	0	0	0	0
Lesser snow	525	800	475	400	400	0	0	0	0	0	0	0	0	0	0	0	0
Canada	634	651	238	22	27	115	72	18	0	6	0	0	25	22	0	0	0
Subtotal geese	1,159	1,458	715	422	439	120	77	18	0	6	2	0	25	22	0	0	0
Ducks																	
Green-winged teal	0	0	64	8	73	220	130	84	62	29	19	47	17	13	9	27	2
Mallard	22	63	167	114	51	36	13	32	41	12	30	21	52	4	8	22	34
Northern pintail	42	173	611	290	198	412	190	79	17	21	13	6	27	0	0	8	0
Northern shoveler	0	0	0	0	3	4	12	32	12	21	3	14	20	6	0	0	0
American wigeon	0	0	0	66	63	59	24	63	43	62	96	10	19	27	32	4	2
Scaup	0	0	0	0	0	0	0	0	0	0	0	0	0	0	0	0	0
Bufflehead	0	0	0	5	5	0	2	5	0	0	0	0	0	0	0	0	0
Unidentified duck	0	0	0	0	0	0	0	0	0	0	0	0	0	2	37	0	0
Subtotal ducks	64	236	842	483	393	731	371	295	175	145	161	98	135	52	86	61	38
Other birds																	
Loon	0	0	0	0	0	0	0	0	0	0	0	0	0	0	0	0	0
Bald eagle	2	2	2	0	0	1	3	1	0	0	0	0	1	1	0	0	1
Northern harrier	0	0	0	0	0	0	0	1	0	0	0	0	0	0	0	0	0
Peregrine falcon	0	0	0	0	0	0	1	0	0	0	0	0	0	0	0	0	0
Sandhill crane	0	0	5	4	9	2	5	2	2		16	2	6	6	4	0	0
Shorebird	0	2	0	5	0	56	107	195	31	59	177	61	17	256	50	92	119
Gull	85	129	132	93	66	55	55	31	19	7	27	57	36	19	34	0	0
Arctic tern	0	0	0	4	0	6	10	10	4	8	21	4	6	2	7	29	6
Common raven	0	0	0	0	0	0	2	0	0	0	0	0	0	0	0	0	0

II-1. WATERBIRD UTILIZATION

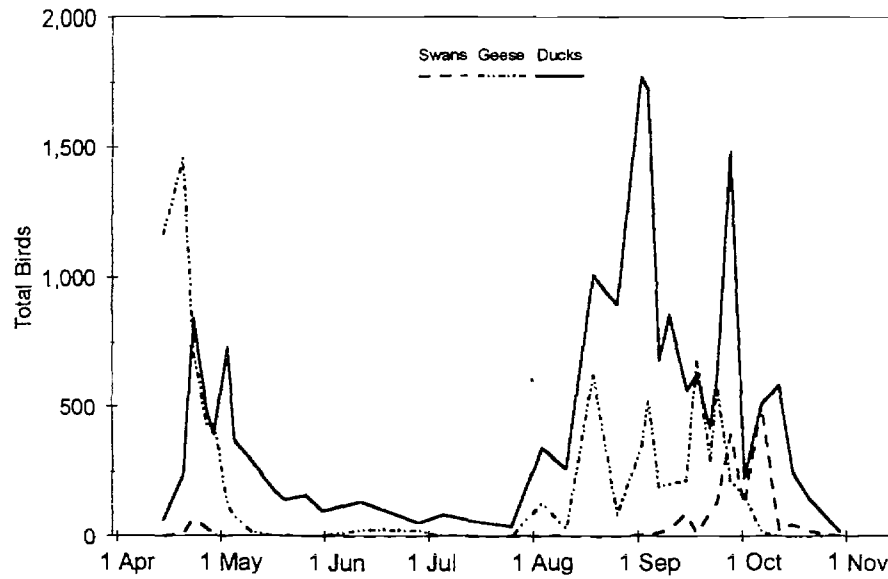

Figure II-1-2. Numbers of swans, geese, and ducks counted on ERF during aerial surveys in 1998.

Table II-1-2. Mean numbers of waterfowl groups in 1998 by season. The number of complete surveys used to classify observations by area, for spring, summer, and fall were 11, 6, and 19, respectively.

	Coastal West	A	B	Racine Island	C	CD	Bread Truck Pond	Coastal East	D
Spring									
Swans	0.0	5.1	2.5	0.0	1.3	0.0	0.0	0.2	1.5
Geese	101.5	83.4	133.4	1.4	18.6	0.4	2.2	12.3	0.2
Greater white-fronted	0.0	0.0	2.4	0.0	0.5	0.0	0.0	0.0	0.2
Lesser snow	31.8	75.0	113.6	0.0	0.0	0.0	0.0	0.0	0.0
Canada	69.7	8.4	17.4	1.4	18.2	0.4	2.2	12.3	0.0
Ducks	19.2	98.0	69.5	10.5	50.5	29.2	9.3	11.3	56.6
Summer									
Swans	0.0	0.0	0.0	0.0	0.0	0.0	0.0	0.0	0.0
Geese	0.0	0.0	0.0	7.8	0.0	0.0	0.0	0.0	0.0
Greater white-fronted	0.0	0.0	0.0	0.0	0.0	0.0	0.0	0.0	0.0
Lesser snow	0.0	0.0	0.0	0.0	0.0	0.0	0.0	0.0	0.0
Canada	0.0	0.0	0.0	0.0	0.0	0.0	0.0	0.0	0.0
Ducks	3.5	18.0	15.0	0.7	7.8	21.8	0.0	2.8	8.7
Fall									
Swans	0.4	3.7	23.9	0.0	0.0	4.2	0.1	13.0	33.7
Geese	136.0	13.5	5.1	2.8	11.6	1.6	4.7	50.9	0.4
Greater white-fronted	2.2	1.5	3.2	0.0	2.4	1.6	0.8	3.8	0.0
Lesser snow	0.0	0.0	0.0	0.0	0.0	0.0	0.0	0.0	0.0
Canada	133.8	12.0	1.9	2.8	9.2	0.0	3.8	47.1	0.4
Ducks	115.0	36.2	157.7	7.1	31.4	99.9	12.5	137.5	87.2

Table II-1-3. Percent duck use of major habitat types by season on ERF in 1998. Four surveys conducted in the fall did not classify ducks to habitat type, and are not included in calculations.

	(n)	Ponds	Krik shoreline	Eagle River	Tidal sloughs
Spring	(3,896)	99	0	1	0
Summer	(470)	93	0	7	0
Fall	(10,543)	73	23	2	2

maximum of 67 observed on 24 April. The mean spring count of 10 swans per survey is above the 3 birds per survey of 1997, but still considerably below the 1988–95 mean of 38. Swans used permanent ponds in Areas A and B most in spring 1998, similar to 1997 (Table II-1-1, Fig. II-1-3).

In fall, swan numbers peaked on 7 October at 507 birds. The mean fall count of 77 swans was higher than the 36 swans per survey of 1997, which was the lowest recorded, but still considerably below the 1988–95 mean of 213 birds per survey. Swans were recorded on ERF until 21 October. Swans used areas D

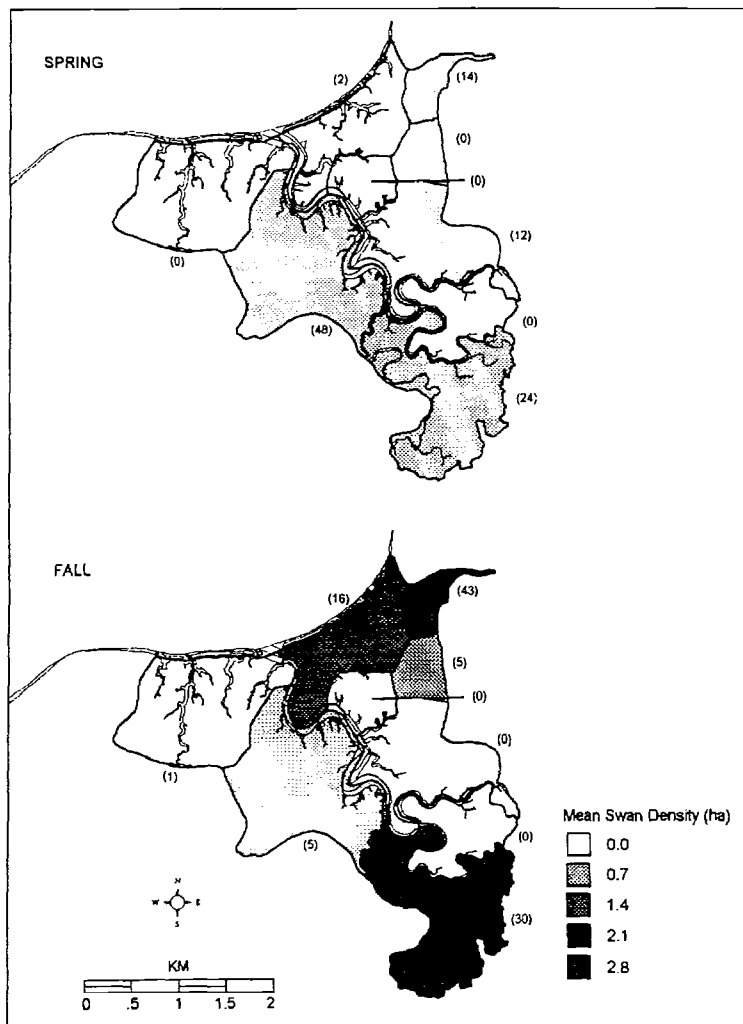

Figure II-1-3. Mean densities of swans on ERF study areas in spring and fall 1998. Numbers in parentheses are the percentage of total swans observed in each area. The number (ha) of permanent and intermittent ponds in each area was used to calculate densities.

and B most during fall (Table II-1-1, Fig. II-1-3), similar to other years. Two dead swans were observed during aerial surveys in the fall, one each in Areas B and D.

Geese

Counts of geese peaked during the third week of April, primarily because of lesser snow geese (*Chen caerulescens caerulescens*) (Table II-1-1, Fig. II-1-4). Snow geese composed 59% of the total geese counted in spring, followed by Canada geese (*Branta canadensis*). Small numbers of Pacific white-fronted geese (*Anser albifrons frontalis*) and Tule white-fronted geese (*A. a. gambelli*) were observed, similar to other years. Mean spring numbers of geese were highest in Area B, Coastal West and Area A (Table II-1-2, Fig. II-1-4).

A small number of Canada geese usually use ERF during summer for breeding or brood rearing, but none were observed in 1998. Fall goose migration phenology was similar to other years, peaking in mid-September (Table II-1-1, Fig. II-1-4). Tule white-fronted geese made up 5% and Canada geese 95% of the total fall numbers of geese. Snow geese and Pacific white-fronted geese rarely migrate through Cook Inlet during fall. Coastal West was the most important area for geese in fall (Table II-1-2, Fig. II-1-4), similar to other years.

Ducks

Duck species utilizing ERF in 1998 were similar to other years (Table II-1-1). Of the four major habitat types used to classify duck locations, ponds were the most important (Table II-1-3). Dabbling ducks composed 96% of the

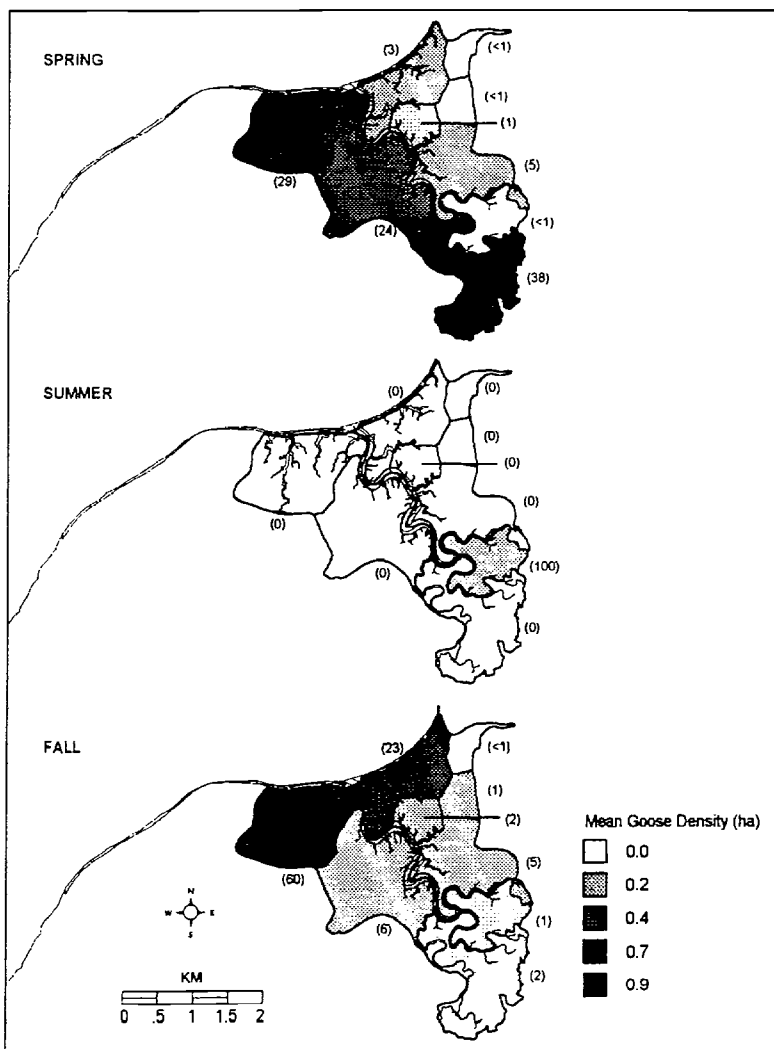

Figure II-1-4. Mean densities of geese on ERF study areas in spring, summer, and fall 1998. Numbers in parentheses are the percentage of total geese observed in each area.

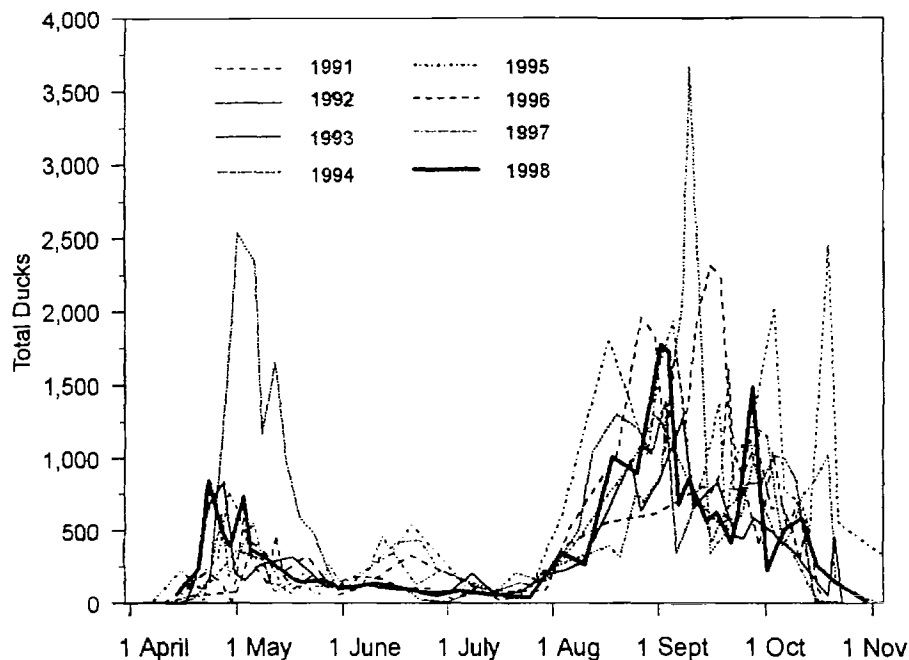

Figure II-1-5. Numbers of ducks observed during aerial surveys of ERF, 1991–1998.

ducks counted through the season. Mallards (*Anas platyrhynchos*), American wigeon (*A. americana*), American green-winged teal (*A. crecca*), northern pintail (*A. acuta*) and northern shoveler (*A. chlypeata*) were the most common species observed. Numbers of all species of ducks combined are presented for 1991–98 (Fig. II-1-5).

In spring the numbers of ducks peaked on 24 April and 4 May (Table II-1-1, Fig. II-1-5). The mean number of ducks in spring, 354, was similar to the 1988–97 mean of 304. Ducks utilized Areas A and B most during spring (Table II-1-2, Fig. II-1-6).

The mean number of ducks per survey in summer, 78, was considerably lower than the 1988–97 mean of 190. Excellent water conditions elsewhere in Cook Inlet may have encouraged birds to use other marshes during 1998. Ducks utilized the CD area most during summer, followed by Areas A and B (Table II-1-2, Fig. II-1-6). As in previous years, broods of American wigeon and mallards were observed on ERF during summer.

Migration phenology for ducks in fall 1998

was similar to other years, with peak counts occurring on 2, 4, and 28 September (Table II-1-1, Fig. II-1-6). The mean number of ducks observed in the fall, 684, was approximately 30% lower than the 1988–97 mean of 836. Ducks utilized Areas B, Coastal East, and Coastal West most during fall (Table II-1-2), with highest densities in Areas CD, B, and Coastal West (Fig. II-1-6). The high values recorded for Coastal West and East reflect numbers recorded along the Cook Inlet shoreline rather than actual use of ponds within these areas. Observations of ducks were also recorded by individual pond, as well as study area, when possible. While it was not possible to separate small ponds in complex systems, use of important, distinguishable ponds was recorded (Fig. II-1-7). The large permanent ponds of Areas B and D were important (Fig. II-1-7), similar to other years.

Changes in fall pond use by ducks

Because of the ongoing treatability studies and attempts to reduce exposure of ducks to white phosphorus, differences between 1997

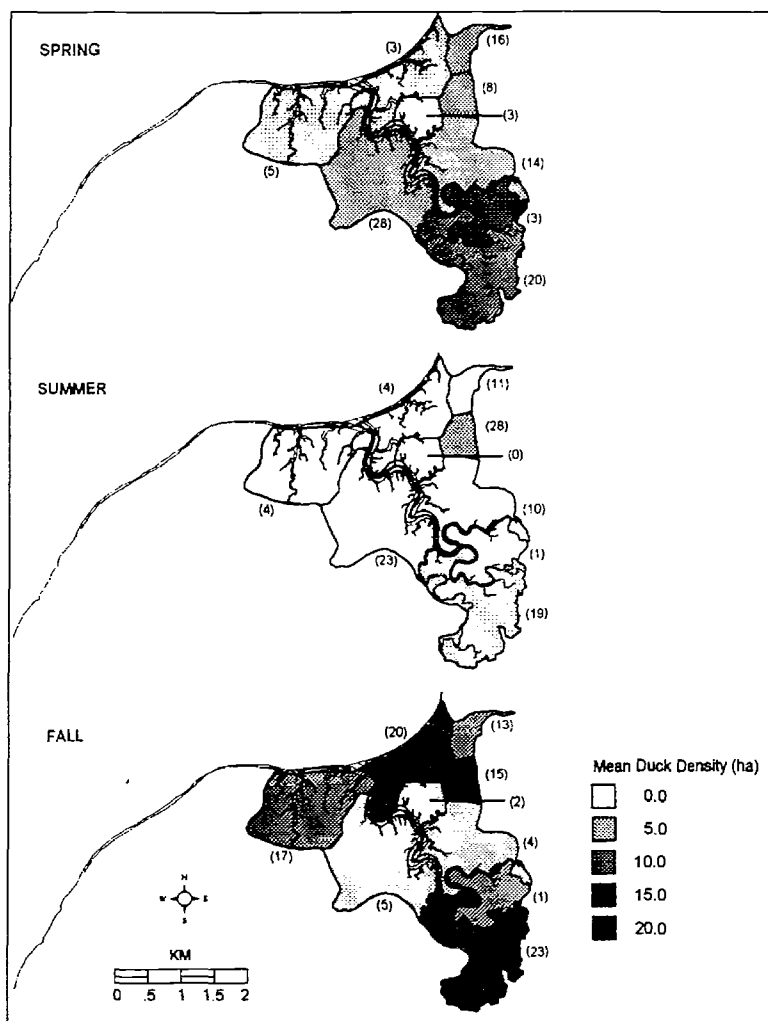

Figure II-1-6. Mean densities of ducks on ERF study areas in spring, summer, and fall 1998. Numbers in parentheses are the percentage of total ducks observed in each area. The number (ha) of permanent and intermittent ponds in each area was used to calculate densities.

and 1998 duck use of study areas and individual ponds were calculated (Table II-1-4). The most important difference was found in Area A, where there was a nearly 62% decrease in duck use. Some of the decrease can be explained by the reduction of water and increased human activity resulting from pumping of some ponds in Area A. These ponds saw reductions in duck use of up to 100% during fall of 1998. The reduced use in other Area A ponds may have been attributable to increased human activity, or a function of the timing of aerial surveys. There was an increase of 34% in Area CD, which could explain increased mortality if this area contains areas or "hot spots" contaminated with

white phosphorus. It appears that efforts to move ducks from Areas A and C to Areas B and D and CD are successful. What is not clear is if ducks are moving to other areas contaminated with white phosphorus and increasing or maintaining their exposure.

Bald eagles

Numbers of bald eagles (*Haliaeetus leucocephalus*) were low, similar to recent years. While specific shoreline surveys for eagles were not conducted, concentrations similar to earlier years of 50 or more eagles would have been noticed. Ground crews counted a maximum of 13 at one time (Cummings, pers. comm.). The nest near the entrance of Eagle

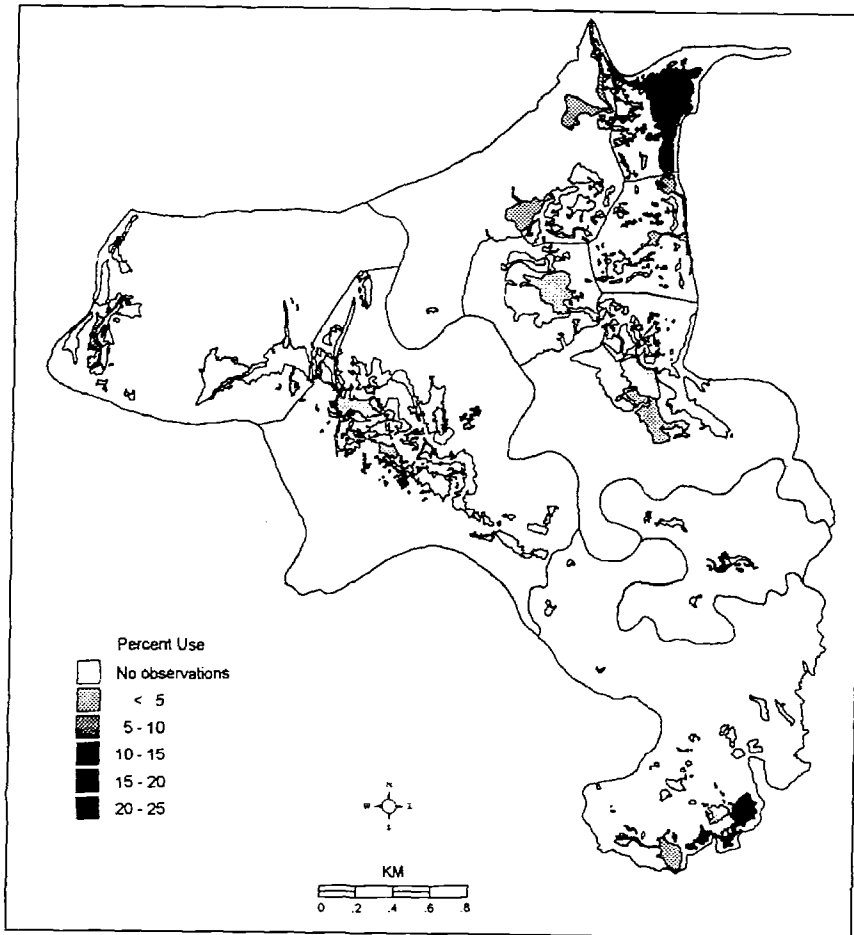

Figure II-1-7. Percentage use of ponds by ducks classified to ponds during aerial surveys in fall 1989.

Table II-1-4. Changes in percent use of ERF study areas and major habitat types by ducks from fall 1997 to fall 1998. Habitat types within study areas used by $\leq 1\%$ of ducks in both years are not listed.

Area/habitat	Percent use		Percent change
	1997	1998	
Coastal West	9.9	17.6	77.8
Ponds	5.6	9.1	62.5
Knik shoreline	4.3	7.6	76.7
A	14.6	5.6	-61.6
Ponds	14.5	5.0	-65.5
B	25.0	19.2	-23.2
Ponds	19.2	18.2	-5.2
Eagle River	5.8	1.0	-82.8
Racine Island	0.6	1.1	83.3
C	17.9	4.8	-73.2
Ponds	2.4	4.7	95.8
Eagle River	15.5	0.1	-99.4
CD	11.4	15.3	34.2
Ponds	11.4	15.3	34.2
Bread Truck Pond	1.3	1.9	46.2
Ponds	1.3	1.9	46.2
Coastal East	9.1	21.1	131.9
Ponds	2.8	9.3	232.1
Knik shoreline	6.3	11.7	85.7
D	10.7	13.4	25.2
Ponds	10.7	13.4	25.2

River onto the flats was not occupied, unlike previous years. The nest on the point west of Coastal West was occupied but not successfully. Lower numbers of eagles in recent years may be attributable to decreased mortality of waterbirds on ERF.

Shorebirds

Numbers of shorebirds were combined for all species since individual species were not

identified from the airplane (Table II-1-1). Numbers of shorebirds were similar to 1997 and lower than other recent years. Common species on ERF include least sandpipers (*Calidris minutilla*), semi-palmated sandpipers (*C. pusilla*), western sandpipers (*C. mauri*), dowitchers (*Limnodromus* spp.), and greater and lesser yellowlegs (*Tringa* spp.). Less common species include red-necked phalarope (*Phalaropus lobatus*) and pectoral sandpiper (*calidris melanotos*).

Gulls and terns

Gull species were combined for aerial surveys (Table II-1-1). They include mew gulls (*Larus canus*), glaucous-winged gulls (*L. glaucescens*), and herring gulls (*L. argentatus*). Arctic terns (*Sterna paradisaea*) were common into July. The mew colony in Area D, formerly numbering up to 25 pairs, now consists of just a few pairs.

Sandhill cranes

Sandhill cranes (*Grus canadensis*) were observed on ERF in small numbers from spring to mid-September, when most leave the state (Table II-1-1). Sandhill cranes often breed on ERF, but no chicks were observed this year during aerial surveys. (Several sandhill crane chicks were observed in Area A during ground-based operations.)

REFERENCES

Racine, C.H. and D.W. Cate (Eds.) (1996) Interagency expanded site investigation: Evaluation of white phosphorous contamination and potential treatability at Eagle River Flats, Alaska. FY 95 Final Report. CRREL Contract Report to U.S. Army, Alaska Directorate of Public Works.

II-2. MOVEMENTS, DISTRIBUTION, AND RELATIVE RISK OF WATERFOWL USING EAGLE RIVER FLATS: 1998

John L. Cummings, Richard E. Johnson, Kenneth S. Gruver, Patricia A. Pochop, Darryl L. York, James E. Davis, and Jean B. Bourassa
National Wildlife Research Center, U.S. Dept. of Agriculture, Wildlife Services, Fort Collins, CO

Charles H. Racine
U.S. Army Cold Regions Research and Engineering Laboratory,
Hanover, NH

INTRODUCTION

The U.S. Army has used Eagle River Flats (ERF), Fort Richardson, Alaska, since 1945 as an impact area for artillery shells, mortar rounds, rockets, grenades, illumination flares, and Army/Air Force Door Gunnery Exercises. In August 1981, hunters discovered large numbers of duck carcasses in ERF. Since that time, the Army and other Federal and state agencies have been involved in identifying the cause of the waterfowl mortality. On 8 February 1990, the Army temporarily suspended firing into Eagle River Flats because of the suspected correlation between explosives and duck deaths. In July 1990, a sediment sample collected from ERF was suspected of containing white phosphorus. By February 1991, it was concluded that white phosphorus in ERF was the cause of waterfowl mortality.

Waterfowl populations, overall, have been decreasing continent-wide. Many factors affect their numbers, such as the availability of breeding, loafing, and feeding habitat. ERF is an important spring (April to May) and fall (August to October) waterfowl feeding and staging area. Contamination of waterfowl feeding areas in ERF with white phosphorus represents a serious hazard.

In 1996, during fall migration, 158 ducks were captured on ERF using various tech-

niques. Of these, 107 mallards and 29 northern pintails were fitted with radio transmitters. Movements and distribution of mallards indicated that they spent about 91% of their time in Areas A, B, C, and C/D. In addition, mallards spent about 83% of their time in areas that are considered contaminated (A, Bread Truck, C, C/D, EOD, and Racine Island). The average number of days spent on ERF by mallards was 47. The average daily turnover rate for waterfowl was about 1.4%. The greatest turnover of waterfowl occurred from 1 to 15 October, when 62% of the mallards departed ERF. The number of mortalities of instrumented mallards using ERF from 3 August to 15 October was 37, or about 35%. The greatest mortality occurred in Area C (35%), Area A (22%), and Areas C/D and Racine Island (16%, respectively). The mortality model estimated that 5413 individual dabblers used ERF from 3 August to 16 October. Dabblers peaked at 2333 individuals between 13 and 16 September. The overall mortality that occurred on ERF was 655 dabblers.

In 1997, 136 mallards were captured; 55 were fitted with standard transmitters and 82 were fitted with mortality transmitters. Mallard movements and distribution indicate that they spent about 88% of their time in Areas A, B, C, and C/D. In addition, mallards spent about 69% of their time in areas that are con-

sidered contaminated (A, Bread Truck, C, C/D, and Racine Island). The average number of days spent on ERF by mallards was 42. The average daily turnover rate for waterfowl was about 1.1%. The greatest turnover of waterfowl occurred from 7 to 16 October, when 52% of the mallards departed ERF. The mortality of instrumented mallards that used ERF from 2 August to 22 October was 35. Of those, 21 were attributed to white phosphorus ingestion. We recovered 15 ducks, 7 of which we analyzed for white phosphorus—5 were positive. The mortality model estimated that 6063 individual dabblers used ERF from 2 August to 22 October. Dabblers peaked at 4398 individuals between 9 and 10 September. The overall mortality on ERF was 240 dabblers.

In 1998, we continued to focus on issues outlined under the CERCLA process for ERF. In the conceptual site model, waterfowl and bald eagles are listed as receptors of the exposure and effects of white phosphorus. On ERF, mallards have been selected as the indicator species to evaluate the effects of white phosphorus on waterfowl. Bald eagles are considered the top avian scavengers of waterfowl poisoned by white phosphorus. In this case, both mallards and bald eagles are considered to be prime species in the ERF food chain that would have direct exposure to white phosphorus and be a significant part of the Ecological Risk Assessment. Telemetry studies have shown that bald eagles are not affected by scavenging dead waterfowl on ERF. Thus, the objectives will address waterfowl only. The objectives, as outlined below, of this study are designed to contribute to remedial decisions concerning ERF.

The objectives for 1998 were to:

1. Determine the daily and seasonal movements and distribution, turnover, and mortality rates of mallards using ERF.
2. Establish baseline data for mallards with respect to proposed remediation actions.

METHODS

Beginning 4 August 1998, we randomly captured mallards from random locations on

ERF using a net-gun from a Bell 212 helicopter. Ducks were individually banded with U.S. Fish and Wildlife Service bands. The capture and release location and date, band number, age, and sex were recorded for each bird. All ducks were also fitted with a radio transmitter (standard or mortality) weighing 9.1 g. All mallards captured were fitted with standard transmitters that provided daily movement, distribution, and mortality data. However, only 60 were monitored for these data; the remaining mallards were used to determine mortality only. Each transmitter was positioned on the upper back of the duck and attached with a Teflon ribbon harness (Cummings et al. 1993).

Mallards were tracked from three fixed telemetry towers that were strategically located on ERF (Fig. II-2-1). Each tracking tower was equipped with a notebook containing radio tracking forms, a directional yagi antenna, a compass for determining telemetry bearings, and a two-way radio for communications. Birds were located simultaneously from each tracking tower. The birds were assumed to be near the point where the bearings crossed, and each bearing location was entered onto a radio tracking form. Also, the Cole Point tower tracker was radioed the telemetry locations for each mallard from the other two tracking towers. The data were immediately entered into the computer program LOCATE II (Pacer, Truro, Nova Scotia, Canada). The program imports each telemetry reading from each telemetry tower and triangulates the location of the duck on a map of ERF. The program uses the length technique, which estimates the most likely true location of the duck (Nams 1990). Data that had an error polygon of greater than 50,000 m² were not included in the data set. The average and median error polygons for mallards on ERF were 11,828 and 4443 m². The data set was transferred from LOCATE to EXCEL and mapped using the GIS software ARCINFO or ARCVIEW, or both.

Birds were also tracked on foot, from hovercraft, or from National Guard helicopters to determine their status. Towers could receive radio-equipped birds up to 25 km

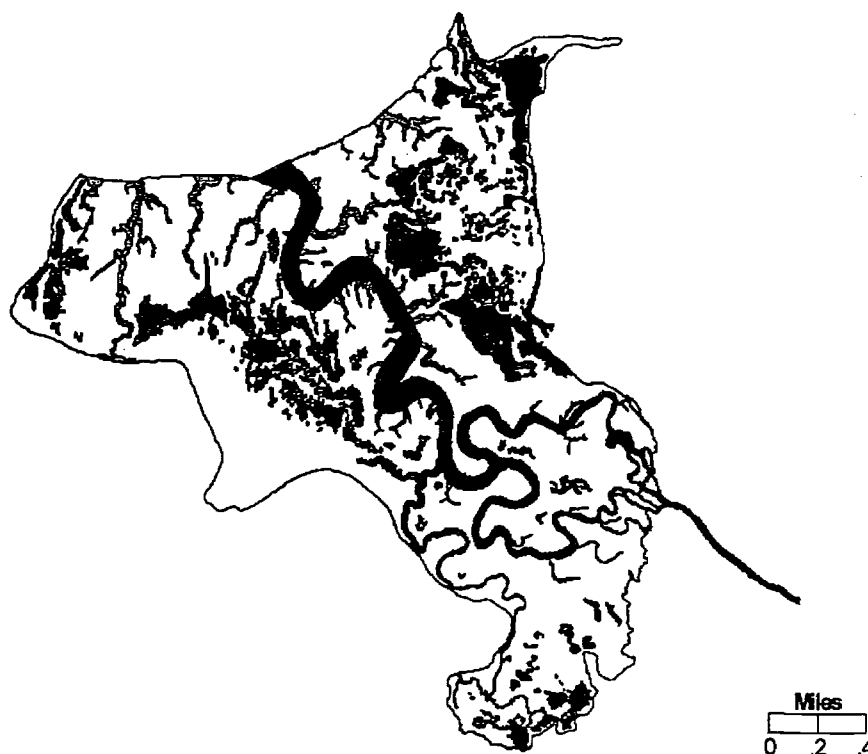

Figure II-2-1. Geographic information system map depicting Eagle River Flats.

from the Flats. Helicopters were used to track birds up to 90 km from the Flats in areas such as the Susitna Flats, Palmer Hay Flats, and Chickaloon Flats.

Telemetry locations were determined daily between 0700 to 1000 and 1500 to 2000 during August, September, and October. Birds that could not be detected as moving or did not move more than 10° in 2–3 days were visually located to determine their status. Mortality radios were recovered once they activated. Dead birds were recovered to determine the cause of death and the location of each was recorded with a Global Positioning System.

In 1995, ERF was divided into ten areas representing sites that waterfowl used for foraging and loafing (Fig. II-2-1). Since that time, telemetry data have been plotted and analyzed on the basis of these ten areas, which are synonymous with areas used by the U.S. Army to identify specific locations on ERF. The ten areas are A, B, RI (Racine Island), C, C/D, D, BT (Bread Truck), EOD, Coastal West, and Coastal East. Areas A, RI, C, and BT have documented high levels of white phosphorus.

In 1998, mallard activity in different areas of ERF was determined by counting the number of telemetry locations within an area, divided by the total number of telemetry locations for that bird and expressing it as a percentage. These data were used to address concerns about the relative risk to mallards and to establish baselines with respect to proposed remediation actions.

The daily turnover rate of instrumented mallards on ERF was determined by dividing the number of radio-instrumented mallards that departed ERF each day by the total mallards instrumented. The daily turnover rate was used to determine the relative white phosphorus risk to birds using ERF.

Mallard mortality and its location were determined by telemetry. The mortality rate was determined by dividing the number of mallard mortalities by the total number of mallards captured and given radios. A mortality model was developed for ERF to determine the number of dabbling ducks that die from ingesting white phosphorus during the fall migration period. Duck census data (Eldridge 1998, unpublished data) and telem-

etry, turnover, and mortality data from 1998 were used in the model. The model formula is:

$$A_1 = A_2 / (D/R) - 1 \rightarrow M = A_1 (M_1) / R$$

where

A_1 = actual number of dabblers using ERF

A_2 = number of dabblers surveyed

D = number of dabblers departing ERF

R = number of radio-equipped ducks

M = projected number of dabbler mortalities on ERF

M_1 = number of radioed duck mortalities.

RESULTS

From 4–13 August 1998, 109 mallards were randomly captured on ERF using a net-gun from a Bell UH1 helicopter. We used 27 hours of helicopter time to capture the mallards. The best capture was 12 mallards in 1 hour. Each mallard was banded and fitted with a 9.1-g backpack transmitter and released at its capture site. All 109 mallards were fitted with standard transmitters but only 60 were continuously monitored. The remaining 49 mallards were monitored for mortality only (Table II-2-1). The behavior of instrumented mallards following release indicated that the transmitters did not inhibit movements or activities. Observations indicated that the behavior of instrumented mallards did not differ from that of other ducks in its associated flock. On some occasions, instrumented birds were observed leading flights of ducks. However, about 4% of the instrumented mallards were in final stages of molt when captured. These ducks remained in the capture–release areas

Table II-2-1. Radio transmitters fitted to mallards since 1996 on Eagle River Flats, Fort Richardson, Alaska.

Year	Standard	Mortality	Total
1996	53	54	107
1997	55	81	136
1998	60	49	109

longer than the same species that had completed molt.

The GIS system produced two types of maps for each mallard. The first map showed mallard telemetry points before and after 26 August, which coincides with pumping remediation (Fig. II-2-2, which is an actual example). The second map depicts the last 5 to 10 telemetry locations of mallards that died from white phosphorus (Fig. II-2-3, which is an actual example). These maps ($n = 23$) were useful in determining a general area in which the mallards could have been exposed to white phosphorus. Exact locations and, on occasion, even the general location of where the duck might have ingested white phosphorus were difficult to discern because a duck may have died on the weekend when personnel did not work.

Mallard ($n = 60$) movements and distribution on ERF during the fall indicate that they spent the majority (75%) of their time from 4 August to 22 October in Areas A, B, C, and C/D (Fig. II-2-4). In addition, mallards spent about 65% of their time in areas that are considered to be contaminated (A, BT, C, C/D, and RI). Of the 2758 telemetry locations, 276 were in the Racine quadrant, 653 were in the A quadrant, 14 were in the BT quadrant, 404 were in the C quadrant, and 399 in the C/D quadrant. Mallards were only located 6 of 276 times in the actual Racine Pond and 2 of 14 times in the actual Bread Truck Pond. Several mallards were documented moving to various locations near ERF, such as Gwen, Otter, and Six Mile lakes, Palmer Hay Flats, Susitna Flats and the Anchorage Bowl.

To evaluate the effects of pumping on mallards, we compared mallard movements and distribution during (from 26 August to 22 October) and following pond pumping in 1998 (Fig. II-2-5). We also compared mallard activity from 1998 to 1996 and 1997. In Area A, two pumps were installed in 1998. In 1996 and 1997, mallards used Area A about 28% of the time. In 1998, mallards use of the same area, during the same time, was about 8%, which is a significant decrease in use that can be attributed to pumping. Mallard activity in Area A following the shut down of the pumps

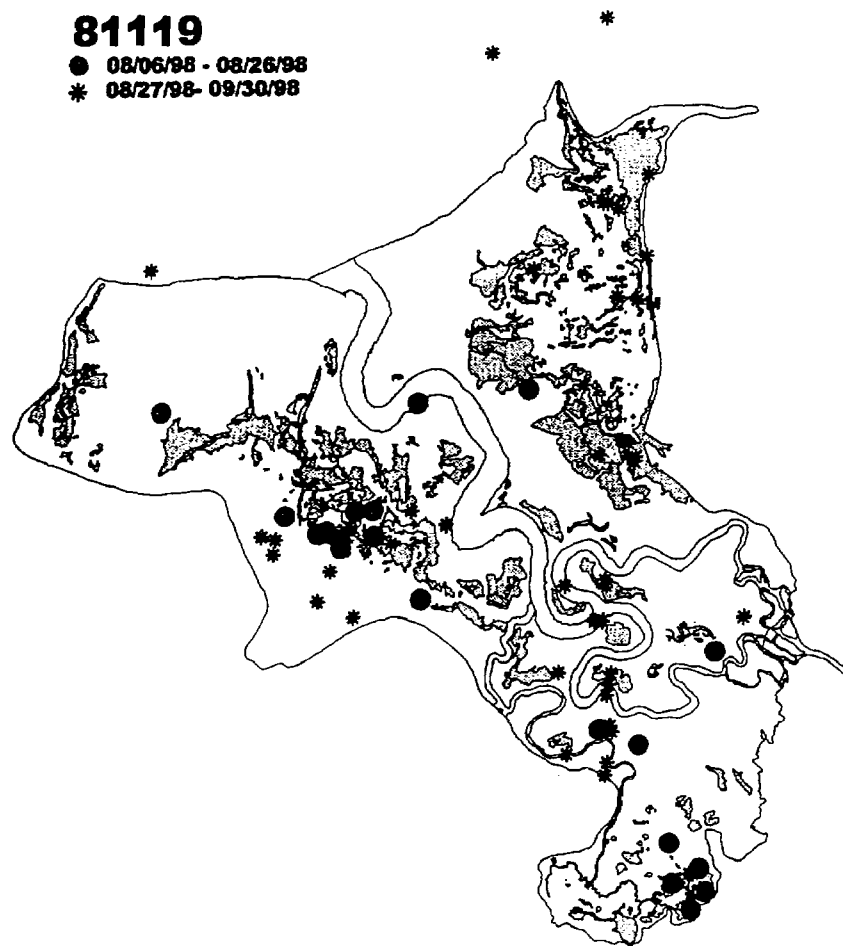

Figure II-2-2. Example of a GIS map of radiotelemetry results on Eagle River Flats showing the movement patterns of a mallard from 4 August to 22 October 1998. Circles represent movements from 4 to 26 August and stars represent movements from 27 August to 22 October. One symbol may represent several telemetry locations.

in 1998 was similar to 1996 (18%) and 1997 (22%). Mallard activity in Area C in 1998 increased about five-fold when the pumps were shut down. All areas that were directly pumped saw no use by waterfowl when the pumping system was in operation. In 1996, mallards spent 33% of their time in Areas A, C, C/D, and BT prior to 6 September and 46% of their time in the same areas after 6 September. In 1997, mallards spent 39% of their time in Areas A, C, C/D, and BT prior to 6 September and 23% of their time in the same areas after.

The average and median number of days mallards ($n = 60$) spent on ERF were 48 and 53, respectively. The range was from 1–75 days. At the conclusion of the study, 22 Octo-

ber, 22 mallards remained on ERF. These birds were using the Eagle River and some open water in Areas B, C/D, and D. In previous years, the ponded areas on ERF were completely frozen, which caused most ducks to leave the area. The average daily turnover rate for mallards was about 1.4%. The greatest turnover of mallards occurred from 4 to 19 August and from 13 to 22 October, where 75 (68%) of the mallards departed ERF during these periods (see Table II-2-4).

Thirty-five radio-instrumented mallards that used ERF between 2 August and 22 October died (Table II-2-2). Of those, 29 were attributed to white phosphorus, 5 were shot by hunters, and 1 was caught by a falcon. Mal-

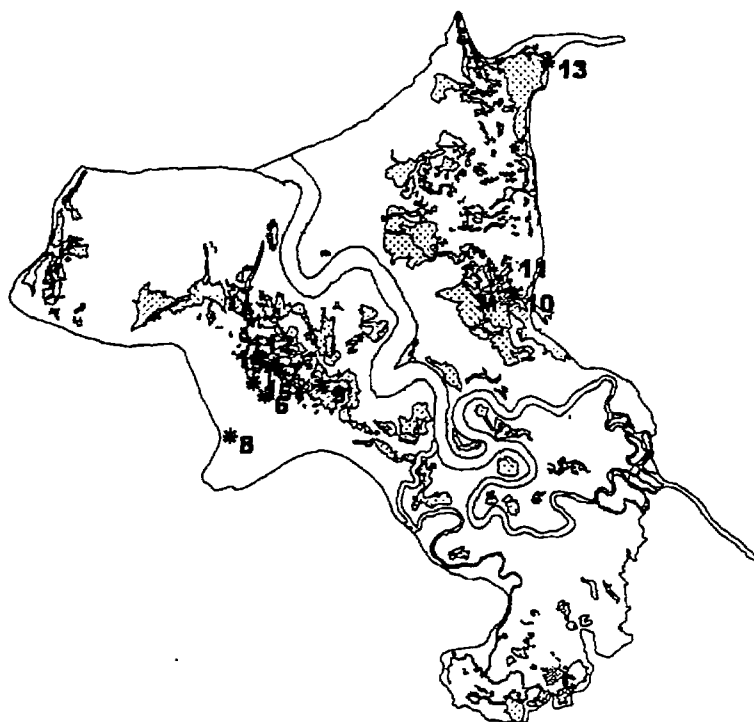

Figure II-2-3. Example of a GIS map depicting radiotelemetry results of a mallard that died from ingesting white phosphorus. Numbered dots represent movements prior to death.

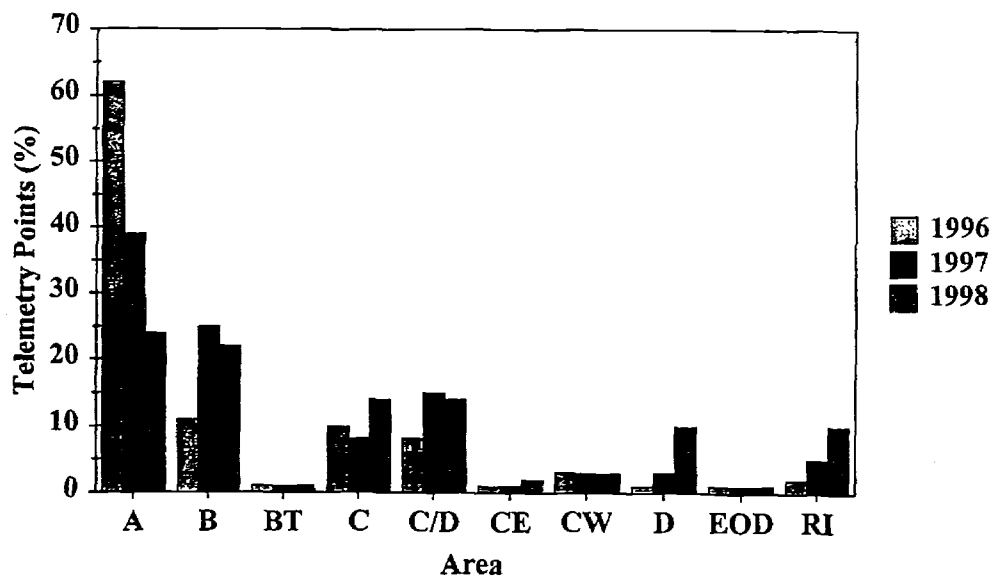

Figure II-2-4. Distribution of radio-equipped mallards on Eagle River Flats during August, September, and October, 1996 to 1998 (middle histograms are 1997).

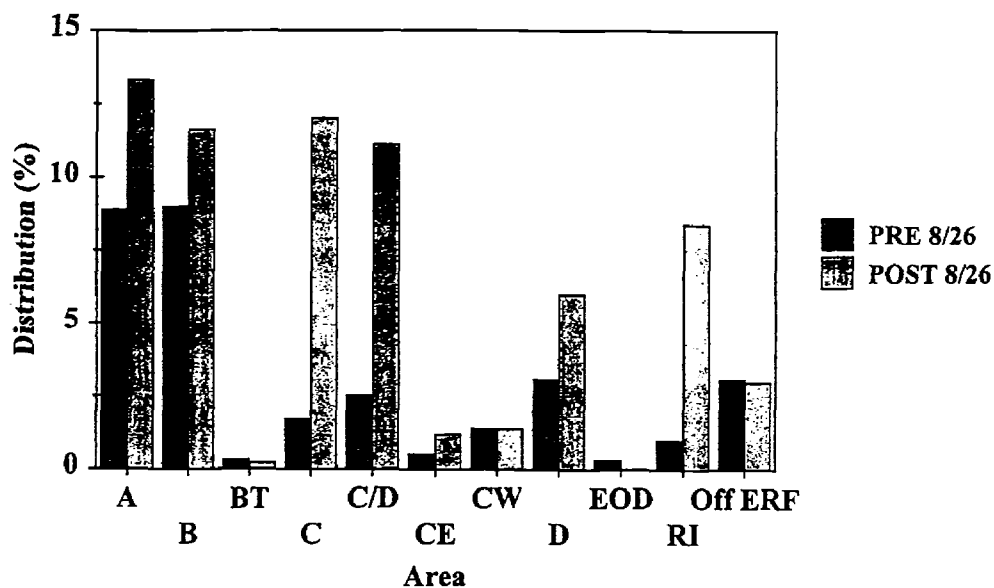

Figure II-2-5. Distribution of mallards relative to pond pumping on Eagle River Flats before 26 August and after 26 August 1998.

lards that were found dead on ERF had used the Flats from 4 to 72 days. The average exposure before mortality was 27 days. Mortality occurred as follows: in Area C/D, 12 of 29 (41%); in Area A, 5 of 29 (17%); in Area C, 5 of 29 (17%); in Area RI, 4 of 29 (14%); and in Area B, 3 of 29 (10%) (Fig. II-2-6). These areas accounted for all mallard mortalities on ERF. No mallards died in Bread Truck Pond, but three died in the ponded areas on Racine Island. No mallard mortality was noted from capture, handling, or the transmitter. First duck mortalities occurred 8 days after capture. In most telemetry studies, mortality from capture, handling, or the transmitter will occur within 2 days. Of the 11 duck mortalities during the first monitoring period (14 days), 7 contained WP and 4 were scavenged. The distribution of mallards varied by year (Fig II-2-7). We recovered 13 whole duck bodies from the 29 white phosphorus mortalities. Analysis showed that 10 were positive for white phosphorus (Table II-2-3). White phosphorus levels in eight waterfowl (3 MLD, 3 PNT, 1 AWG, 1 GWT) collected from Area A were $x = 28.5$ $\mu\text{g/g}$ (range 0.05 to 72.8 $\mu\text{g/g}$); in one collected in Area C (1 MLD) was 0.41 $\mu\text{g/g}$; in

one collected in Area C/D (1 PNT) was less than MLOD; in one collected in Area RI (1 GWT) was 0.46 $\mu\text{g/g}$; and in one collected in area D (1 Tundra swan) was 95.9 $\mu\text{g/g}$.

A mortality model was developed for ERF to estimate the total individual number of dabblers using ERF, the peak number of dabblers using ERF, and the total number of dabbler mortalities on ERF during the fall migration period. We used the number of mallards with radios, the aerial census counts of waterfowl on ERF, and the number of mallard mortalities on ERF in the model. In 1996, 5413 individual dabblers used ERF from 3 August to 16 October. Dabblers peaked at 2333 indi-

Table II-2-2. Mallard mortalities from white phosphorus (WP) during August, September, and October on Eagle River Flats from 1996 to 1998.

Year	Captured	Mortalities	WP mortalities
1996	107	42	37
1997	136	35	21
1998	109	35	29



Figure II-2-6. Mallard mortality locations on Eagle River Flats in 1998.

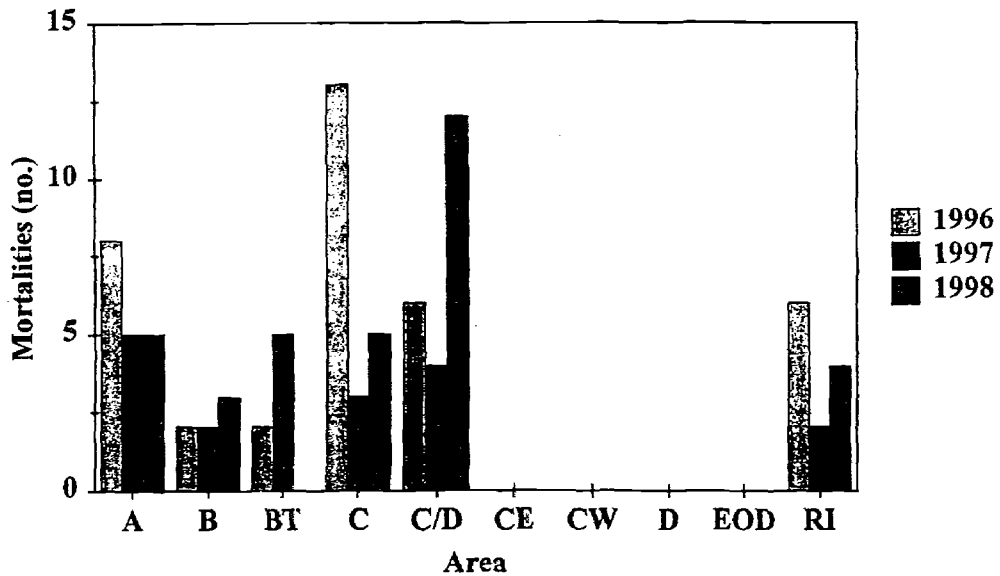

Figure II-2-7. Distribution of mallard mortalities on Eagle River Flats during August, September, and October 1996 to 1998 (middle histogram is 1997, except in the case of BT, where it is the second).

II-2. MOVEMENTS, DISTRIBUTION, AND RISK

Table II-2-3. Mallards recovered from Eagle River Flats and tested for white phosphorus, 1996 to 1998.

Year	Mortalities	Tested	Positive
1996*	37	8	8
1997	21	7	5
1998	29	13	10

*One mallard captured in 1996 died in 1998, but is included in the 1996 data.

viduals between 13 and 16 September. The overall mortality that occurred on ERF was 655 dabblers. In 1997, 6063 individual dabblers used ERF from 2 August to 22 October. Dabblers peaked at 4398 individuals between 9 and 10 September. The overall mortality that occurred on ERF was 240 dabblers. In 1998, 3772 individual dabblers used ERF from 4 August to 22 October. Dabblers peaked at 1583 individuals between 27 August and 28 September. The overall mortality that occurred on ERF was 355 dabblers (Table II-2-

4). These data represent a minimum number of mortalities on ERF during the fall migration period. Mallard mortality during the spring migration has been estimated at about 50% of the fall migration period (Cummings et al. 1994, 1995, 1996). Thus, overall mortality for 1996 was 983 dabblers, for 1997 was 360 dabblers, and for 1998 was 532 dabblers. Mortality decreased about 63% from 1996 to 1997 but increased about 48% from 1997 to 1998. The decrease is attributed to remediation actions such as pumping, draining, and aqua-blok. The increase in mortality in 1998 might be caused by a redistribution of a greater number of waterfowl into contaminated areas.

DISCUSSION

In 1996, 1997, and 1998, mallards were selected as the indicator species to measure the effects of any treatability studies or remediation actions on ERF. The 1996, 1997, and 1998 sample sizes of 107, 136, and 109,

Table II-2-4. Mortality model for Eagle River Flats, 4 August to 22 October 1998.

Date	Radio-equipped birds (no.)	Turnover (no.)	Mortality (no.)	Dabblers surveyed			Adjusted for turnover (no.)	Projected mortality ² (no.)
				Aerial counts (no.)	Unknown dabblers ¹ (no.)	Total dabblers (no.)		
08/04-08/19	109	27	11	270	585	855	1,137	114
08/20-08/26	82	9	3	242	617	859	965	35
08/27-09/02	73	3	1	319	1,199	1,518	1,583	22
09/03-09/04	70	7	3	665	589	1,254	1,393	60
09/05-09/07	63	0	0	426	10	436	436	0
09/08-09/10	63	0	0	838	0	838	838	0
09/11-09/15	63	0	0	490	0	490	490	0
09/16-09/18	63	3	2	605	0	605	635	20
09/19-09/22	60	3	2	302	1	303	319	11
09/23-09/24	57	0	0	515	38	553	553	0
09/25-09/28	57	3	2	1,148	190	1,338	1,412	49
09/29-10/02	54	2	1	181	45	226	234	4
10/03-10/07	52	3	2	448	0	488	517	20
10/08-10/12	49	1	0	481	69	550	561	0
10/13-10/16	48	26	2	224	0	224	489	20
10/17-10/22	22	22	0	148	0	148	148	0
Total	109	109	29	7,302	4,181	9,847	11,710	355

¹Dabblers represent 95% of unknown ducks.

²Minimum number of dabbler duck mortalities on ERF during fall migration, 4 August to 22 October 1998.

respectively, radio-equipped mallards were large enough to establish a baseline against which future changes in mallard movements, distribution, turnover, and mortality can be detected with confidence. Any comparison of the data from 1996, 1997, and 1998 with those of 1993, 1994, and 1995 must be carefully interpreted because of the small sample size of captured mallards in 1993, 1994, and 1995. Also, other activities on the Flats during those years, such as hazing, data collection, and movement of personnel are all factors that may influence waterfowl behavior. However, we feel confident that data from 1996, 1997, and 1998 can be used to make decisions about future remediation actions.

Mallards highly preferred area A in 1998, followed by areas B, C, and C/D. These were the same areas that mallards preferred in 1996 and 1997. The distribution of mallards in 1996 and 1997 showed a larger use of ERF in August than in September and October. Remediation actions such as draining and pumping caused ducks to redistribute to other ponded areas. In 1998, these activities may have caused more ducks to concentrate in contaminated areas (A, C, and C/D).

The average number of days mallards spent on ERF was 47 in 1996, 42 in 1997 and 48 in 1998. Weather is a factor that affects the length of time mallards spend on the Flats. In 1997, ponded areas started freezing in the latter part of September, which caused ducks to leave ERF for open water. In many cases ducks moved to the river until ice flows eliminated foraging opportunities. The average daily turnover rate was 1.4% in 1996, 1.1% in 1997, and 1.4% in 1998.

The mortality model predicted 655 duck deaths during the fall migration period in 1996, 240 in 1997, and 355 in 1998. The increase of mallard mortalities on ERF from 1997 to 1998 can be attributed to remediation actions, which caused more ducks to concentrate in contaminated areas. However, overall duck mortality has decreased 47% from 1996.

The mortality model for ERF is a more accurate predictor of the actual numbers of ducks that die from white phosphorus ingestion than trying to extrapolate the percentage of telemetry mortalities to the ERF duck population. The model combines all the data from telemetry-monitored ducks, which includes numbers, mortality, and turnover, and the aerial census, to predict the actual number of ducks that die from white phosphorus ingestion. The advantage of the model is that it uses the above factors to project the mortality by day, week, or month. In trying to extrapolate the percent mortality from telemetry-monitored ducks to the ERF duck population, we encounter the problem that this percentage represents what has occurred over the entire period and does not take into account when ducks use the Flats, the exact number of individual ducks using the Flats, and the turnover rates.

In conclusion, we feel that the baseline data collected in 1996, 1997, and 1998 can be used to measure the effects of future remediation actions. Showing a significant effect will depend on having a sample size that exceeds 100 mallards captured in a relatively short period.

RECOMMENDATIONS

Assessment endpoints

The biological assessment endpoint for ERF is the reduction in waterfowl mortality. To measure this, we suggest that mallards continue to be used as the indicator species for ERF and that telemetry be used to monitor their activities. Increasing the number of transmitters by 50 will only reduce the standard deviation by about 2%. In addition, a mix of standard and mortality transmitters will allow a broad evaluation of factors affected by remediation actions.

Of importance is being able to determine if remediation actions reduce mortality. Be-

cause waterfowl use the entire ERF, remediation of one area doesn't necessarily mean that mortality will decrease. Waterfowl might redistribute to other sites. It has been shown that telemetry can account for factors affecting mortality, whereas transects that are tied to a specific ponded site cannot. It is recommended that we continue to integrate telemetry data into the risk assessment process, that future remediation actions be assessed with telemetry-monitored birds, and that mortality on ERF be assessed by instrumenting more than 100 waterfowl with mortality transmitters.

Use of telemetry

Monitoring ducks with telemetry does the following:

- Reduces human exposure to UXO's.
- Supports measuring the assessment endpoints with relatively good confidence limits, i.e., to reach 17% WP mortality in 2006, with a 150-radioed-mallards sample, $cf = \pm 6\%$.

REFERENCES

- Cummings, J.L., et al.** (1993) U.S. Army Eagle River Flats: Protecting waterfowl from ingesting white phosphorus. National Wildlife Research Center, Final Report 94-1.
- Cummings, J.L., et al.** (1994) U.S. Army Eagle River Flats: Protecting waterfowl from ingesting white phosphorus. National Wildlife Research Center, Final Report 94-2.
- Cummings, J.L., et al.** (1995) U.S. Army Eagle River Flats: Protecting waterfowl from ingesting white phosphorus. National Wildlife Research Center, Final Report 95-1.
- Cummings, J.L., et al.** (1996) U.S. Army Eagle River Flats: Protecting waterfowl from ingesting white phosphorus. National Wildlife Research Center, Final Report 96-1.
- Cummings, J.L., et al.** (1997) U.S. Army Eagle River Flats: Protecting waterfowl from ingesting white phosphorus. National Wildlife Research Center, Final Report 97-1.
- Nams, V.O.** (1990) LOCATE II user's guide. Pacer Publications.

III-1. Eagle River Flats Pond Pumping Treatability Study: Full-Scale Deployment of Remote Pumping Systems

Michael R. Walsh, Charles M. Collins, and Dennis J. Lambert
U.S. Army Cold Regions Research and Engineering Laboratory,
Hanover, NH

INTRODUCTION

White phosphorus is a highly toxic chemical that does not normally occur in the natural environment. When ingested in small quantities, mg/kg amounts, by waterfowl, its effects can be devastating. In Eagle River Flats, an estuarine salt marsh off Knik Arm near Anchorage, Alaska, this devastation manifested itself in the deaths of thousands of waterfowl a year. Eagle River Flats, situated on Ft. Richardson, has been used for many years by the U.S. military as an artillery impact area. The use of white phosphorus rounds for targeting and practice has resulted in the deposition of unburned material in the many permanent ponds scattered throughout the area (Racine et al. 1992, 1993).

After an extensive Remedial Investigation, which determined the cause of the die-offs, the effects of WP on native flora and fauna, the extent of contamination, and the interaction of the physical environment at the Flats with the persistence of the contaminant, feasibility studies were begun to examine alternative methods of remediation. One alternative under consideration is to pump water out of permanently ponded areas, thus allowing the saturated sediments to desaturate and warm. This process, according to a theory advanced by M.E. Walsh et al. (1995), may enhance the natural attenuation observed in the intermittently ponded borders of the permanent ponds. In 1997, a system was set up in a large, representative pond and run

throughout the summer (Fig. III-1-1). Results were much better than predicted, thus verifying the theory of enhanced natural attenuation by pumping (M.R. Walsh et al. 1998). The method also proved very feasible for a single, easily accessible pond.

The next step in the regulatory process is a treatability study, which entails the development of the methods and technology for deploying multiple systems throughout Eagle River Flats. A total of six sites was chosen, two near the edge of the Flats and easily accessible, one away from shore but still easily accessible, and three across the Eagle River in an area accessible only by helicopter or a long walk. This report describes the work conducted during the treatability study this year and summarizes the results of the field effort. More complete results determining the rates of attenuation attained in the drained ponds can be found in Marianne Walsh's report (M.E. Walsh et al., this volume).

BACKGROUND

Several methods for remediation of white phosphorus at Eagle River Flats have been tested and assessed since 1993. Original efforts concentrated on breaking the contaminant pathway, either through chemical or physical means. Of these methods, covering contaminated areas using a crushed stone or gravel and bentonite mixture was determined to be the most effective (Fig. III-1-2). However,

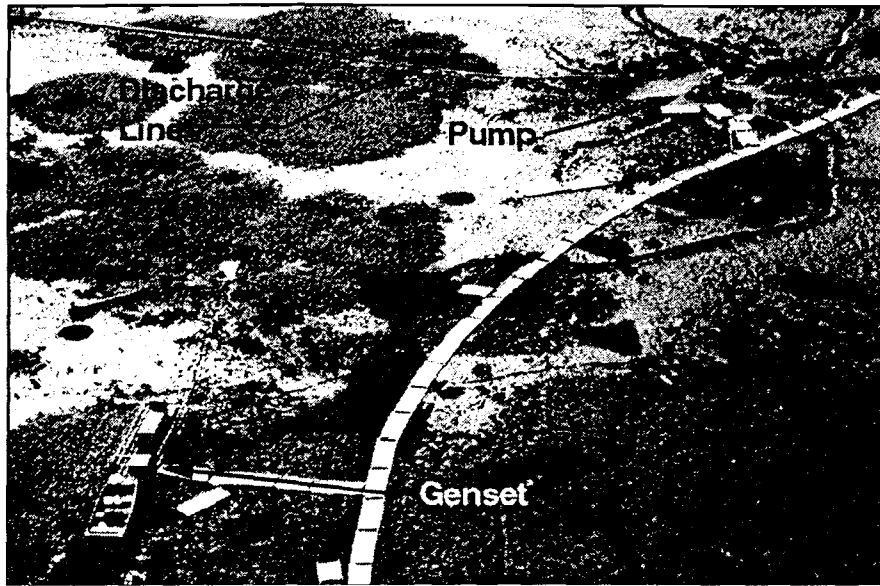

Figure III-1-1. Deployment of pump system in Pond 183, Area C (1997).

this treatment method does not remove the contaminant, and the physical environment's interaction with the covering may be problematic (Lawson et al. 1996). In 1994, a feasibility study was initiated that employed a small 2.5- by 8-m remote-control dredge for removing contaminated sediments from the permanent ponds (M.R. Walsh et al. 1996, 1998). After several technical obstacles were

overcome, an operational dredge was turned over to a local contractor (Fig. III-1-3). Progress was slow and expensive, and problems with the contractor led the Remedial Project Managers (RPMs) to take a harder look at the dredging option.

By the end of the 1996 field season, it became clear to both the RPMs and the investigators involved with the dredge project that

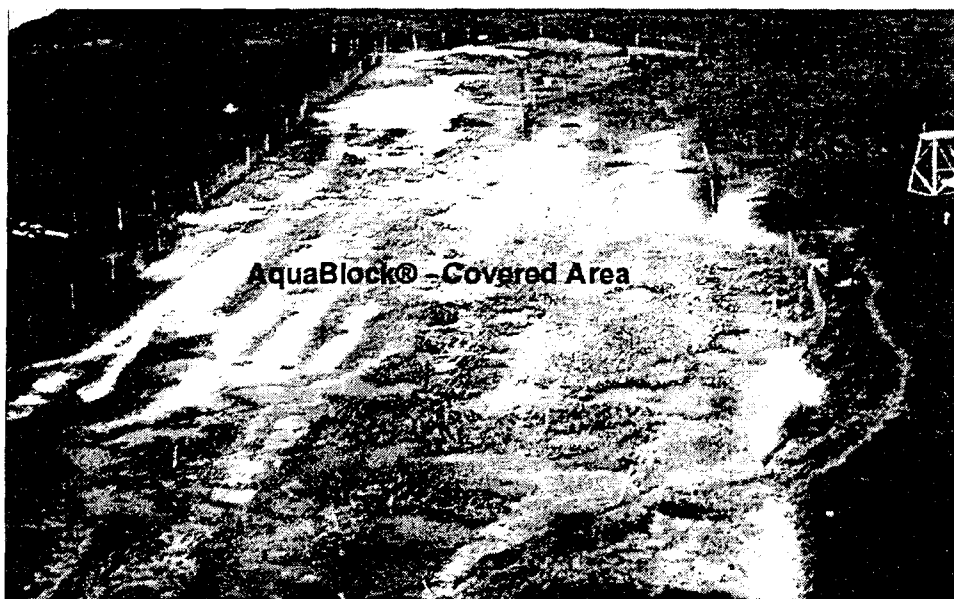

Figure III-1-2. AquaBlock® application in Pond 285, Racine Island (1995).



Figure III-1-3. Dredge in Pond 146 (1996).

full-scale dredging was not going to be feasible at the Flats. The widely scattered contaminant, the presence of large amounts of vegetation and woody debris, the danger from unexploded ordnance, the time and manpower requirements, and the environmental impact all served to reduce the desirability of this option. Although effective in removing the contaminant, it was too time consuming, dangerous, and costly to be considered further. The one remediation option remaining to be tried was wide-scale pond pumping to enhance natural attenuation.

A 126-L/s pump system had been built to order for the initial pond pumping project in 1995 (Collins et al. 1996). This system had originally been designed to operate in Pond 109 (Bread Truck Pond). The pumping feasibility study in 1996 for Pond 109 was cancelled because of funding constraints. Instead, a permanent drainage ditch was excavated using explosives in the spring of 1996. The pump was put into storage until funding became available to test it. In the Spring of 1997, a feasibility study was initiated to test the pond pumping technology in Pond 183, the largest of the permanent ponds in Area C, and one of the most contaminated ponds in the Flats (M.R. Walsh and Collins 1998).

The pump system consists of two units: a 15-cm (6-in.) open-impeller centrifugal pump on floats and an 80-kW generator set (genset) with fuel tanks, also on floats. The two units are tied together by a 70-m-long four-conductor power cord and a control wire. The control wire interfaces between the genset controls and float switches mounted on or near the pump (Fig. III-1-4). The separation of the pump and genset is necessary to prevent damage to the genset and the possible spill of fuel and lubricants in case the pump ingests and detonates unexploded ordnance. The pump was originally going to be placed in the deepest section of the pond to be treated. The pump would then scour a small sump while drawing down the pond. Prior to deployment, however, we decided to blast a sump and place the pump unit within it. Two 18-kg shaped charges and two 18-kg cratering charges were placed and detonated by military engineers to form a 2-m-deep by 6-m sump. The sump serves as a reservoir for the pump, thus reducing the cycling of the system and conserving fuel.

The system was initially installed in May of 1997 (M.R. Walsh et al. 1998). Both the pump and genset were flown to their locations using a UH-60L Blackhawk helicopter

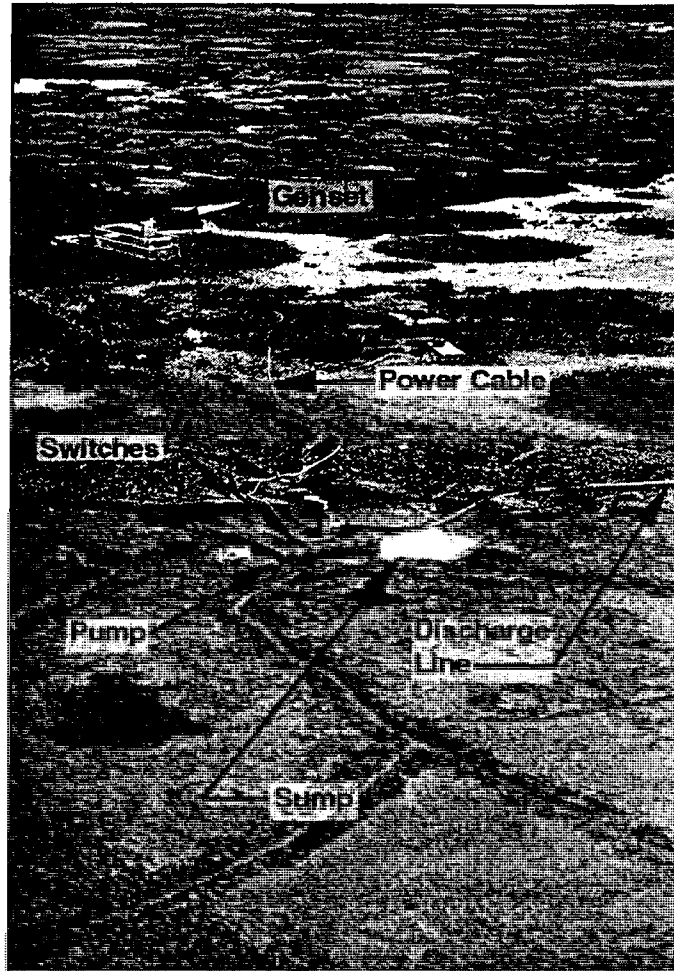

Figure III-1-4. Pump system layout.

(capacity 4080 kg). A 10-cm-diameter discharge line, consisting of 6-m sections of polyethylene pipe and various length sections of rubber hose, was installed between the pump and B-Gully, the nearest natural drainage feature. The pond was pumped down overnight, with the remaining water being confined to small ditches dug by hand and scattered shallow pools.

During the marginal (9.47-m) flooding tide of 20 July, infiltration routes from the river to Pond 183 were scouted. The major infiltration passage for incoming flooding tides was found to be B-Gully. To stop the pond from flooding during marginal tidal floods (less than 9.57 m), a tide gate was designed for the highest, narrowest point of the gully. This gate serves as a one-way valve, preventing influx

of water during lower flooding tides, but allowing water to pass out of the pond after higher flooding tides. A gate was fabricated and installed in September in time to test it during a flooding event (Fig. III-1-5). The gate prevented flooding of the pond.

The final design modification to the system was a check valve for the discharge line. The line, 335 m long, holds approximately 11,000 L of water when full. This is equivalent to one-third the volume of the sump, or 1.5 minutes of pump operation. Preventing the backflow of this water thus increases the time between cycles by at least 30%, a significant duration if the sump is refilling very slowly. The check valve was installed and successfully tested in September (Fig. III-1-6).

Overall, the results of deploying the pump-

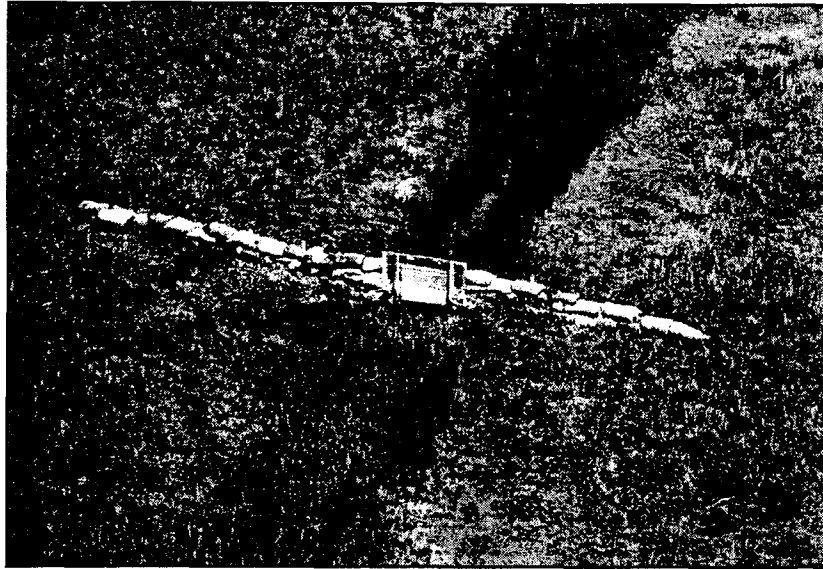

Figure III-1-5. Tide gate.

ing system in Pond 183 during the 1997 field season were much better than originally predicted. Drawdown time after flooding following natural drainage is approximately 3 days for a single pump. If 2 days are allowed for natural drainage and another day is allowed for residual drainage, the total time required for drainage is less than a week following the

last flooding event in a tidal series. We hoped that, with the tide gate deployed, some flooding events could be avoided altogether, thus eliminating subsequent flooding and pumping of the area being treated. Proof of this hypothesis needed to wait until the 1998 season, as the tides in September did not allow sufficient testing of the concept.



Figure III-1-6. Discharge line check valve.



a. Southern A ponds.

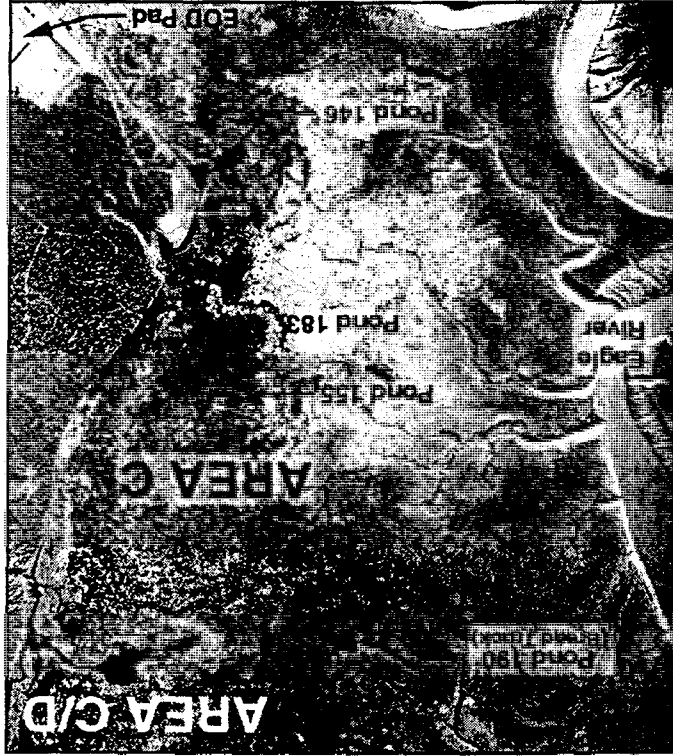

b. Area C, C/D, and Bread Truck.

Figure III-1-7. Aerial photographs of operations areas at Eagle River Flats.

(Appendix III-1-A). This actually simplified the circuitry and eliminated a relay. All four systems, plus the system delivered in 1997, were modified, tested, and operable within 3 days.

The second problem involved a substantial fuel spill. A fuel filter on one of the genset units burst over a holiday weekend, resulting in a spill of approximately 750 L of diesel fuel. Fortunately, this happened on the one shore-based genset (system 3), so, although the gravel pad beneath the unit was contaminated, no fuel entered the flats. The probable cause of the failure is a manufacturing defect in the filter, although the manufacturer disputes this.

The third involved the field exciter for the generator on unit 2. A wire had come loose. This manifested itself as a low generator speed, 1500 rpm vs. 1800 rpm, and overheating of components on one of the controller boards. The system was quickly shut down and a serviceman scheduled for the next day. The disconnected exciter wire was discovered and reconnected, and the cooked controller board replaced. The generator itself survived the incident. The system was up by day's end. Deployment of all systems otherwise went smoothly. Table III-1-1 gives the location of each system and some pertinent information regarding its deployment. Appendix III-1-B contains additional information on the discharge line composition and specifications of all six pump systems. Systems 1, 3, 5, and 6 all

Table III-1-1. Pump system deployments (1998).

System number	Pond	Capacity (L/s)*	Operational date	Discharge line length (m)
1	183	125	1 June	336
2	258	125	25 June	258
3	146	190	27 May	490
4	256	125	23 June	398
5	290	125	28 May	185
6	155	65	1 June	313

*Theoretical capacity. Pump 3 can operate at 63, 126, or 190 L/s.

FULL SCALE DEPLOYMENT

The initial deployment of the 126-L/s pump system in Pond 183 showed that, not only was it feasible to enhance the natural attenuation of white phosphorus from ponded areas using a pump, it was highly effective. Prior to the end of the field season in September 1997, two more sumps were blasted—one in Area A (Pond 290) and an additional one in Area C (Pond 155). These ponds were chosen to further the feasibility study begun in 1997. The Pond 155 deployment was planned to allow us to study the effects of pumping on a group of adjacent, partially connected ponds. Pond 290 was targeted to work out the logistics of pump deployment in a remote area.

In the spring of 1998, the decision was made to attempt to deploy the two pump systems on hand, as well as the four systems on order, in Ponds 146, 155, and 183 in Area C and Ponds 256, 258, and 290 in Area A (Fig. III-1-7). Owing to the magnitude of the deployment, the need to troubleshoot and burn in the four new systems, and the lack of experience with remote deployments, the systems were to be fielded in two stages. This allowed us time to gain experience with a remote system (Pond 290) and to blast the two additional sumps in Area A (Ponds 256 and 258). The pump in Pond 146 would be deployed in the existing dredged channel at the edge of the EOD Pad in the spring.

Some problems developed with the systems over the course of testing, burn-in, and deployment, but most were quickly resolved. Three major problems worth detailing did occur, however. The first concerns the switch logic. As configured on all systems except the original (system 1), the pump can restart during the cool-down cycle if the genset warm-up timer is set lower than the cool-down timer. The immediate way to fix to this problem was to extend the warm-up time and decrease the cool-down time to work around the timing problem. This didn't resolve the underlying logic problem, so the circuitry was redesigned to eliminate the problem altogether.

utilized check valves in the discharge lines to minimize backflow. System 3 discharged directly into the Eagle River, system 5 discharged into Otter Creek, and the remaining systems discharged into the nearest drainage gully. Discharge points in gullies were located at least 15 m from the gully headwalls to keep them from eroding.

In addition to the tide gate installed in B-Gully last year, three additional tide gates were installed at the northern end of Pond 183 in Area C. These tide gates prevented flooding during a 9.54-m (31.3-ft) tide in June. A tide of the same height flooded the area in August from the south, where the river, at a high level, overflowed its banks and infiltrated the area. However, the pond was pumped out within a day and flooding would have been very limited except that one of the generators had run out of fuel and another had been turned off. Area A did not flood during either of these events or during a 9.57-m (31.4-ft) tide, so the tide gates should limit flooding of the southern A Ponds at even higher tidal levels.

One of the most dangerous tasks remaining in installing a new pump system is the digging of drainage ditches from low-lying areas within a pond to the sump. These are

needed to facilitate drainage of the pond, thus reducing the reliance on evaporative drying and increasing the exposure time for sediments contaminated by white phosphorus. These ditches had previously been dug by hand and, even with the assistance of the ordinance detection team, constituted the greatest risk to the pumping team. Experiments conducted in June of 1998 on Racine Island (Fig. III-1-8) indicate that the use of bundled detonation cord, normally used to set off the shaped and cratering charges employed in blowing ditches and sumps at the Flats, will form a small ditch approximately 20 cm deep by 30 cm wide if properly set up. Drainage ditches were successfully blasted in August in Ponds 290, 258, and 256 in Area A. These ditches can be seen as straight lines in the ponds in Figure III-1-7. Five strands of det cord were bundled together and laid in the mud along the planned ditch rights-of-way. Branch lines led from the main ditch to low areas on either side. The det cord was set off with thermal time fuse and a fuse igniter. The resulting explosion created a series of interconnected ditches leading to the sumps where the pumps were located. Only minor shovel work was required after the explosive excavation to maximize flow into the sumps.

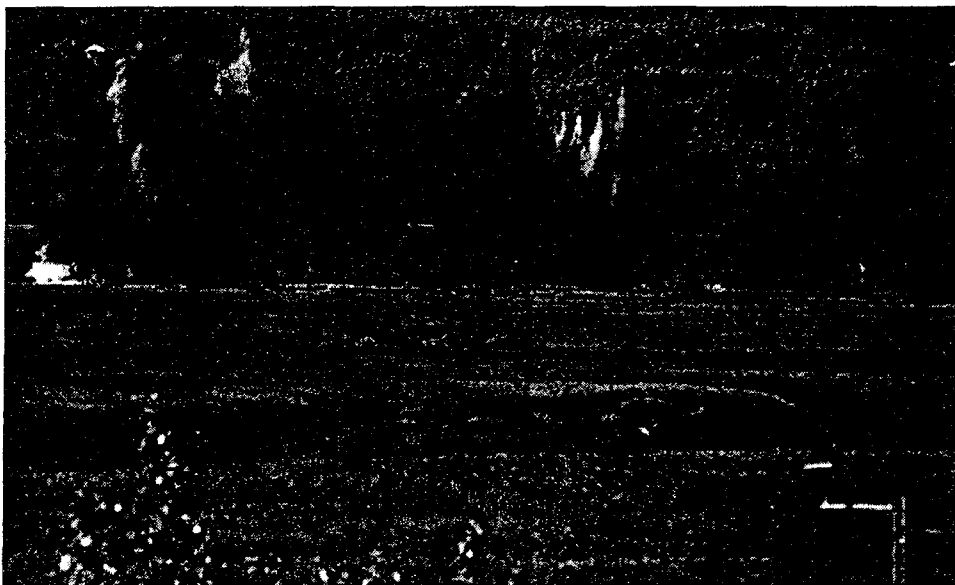

Figure III-1-8. Experimental ditching operation on Racine Island.

Based on these results, further explosive ditching may be done in the spring of 1999.

Refueling of the remote genset systems was the major logistical problem that needed to be solved during the full-scale deployment. A system was located in Pond 290, Area A, to experiment with alternative refueling methods. Originally, military fuel bladders were to be used, but examination of the complex system involved and the possibility of fuel spills during fuel transfer and storage resulted in consideration of alternatives.

Two 1900-L double-walled fuel tanks were available for use at Ft. Richardson. These tanks were fitted with low-ground-pressure base pads. Lifting eyes were added to the tank frames for helicopter transport. A 12-VDC pump with 20 m of refueling hose was added to each tank. These tanks were successfully airlifted to the remote sites at Ponds 290 and 155 for fuelling of these systems (Fig. III-1-9). Later, when systems were installed in Ponds 256 and 258, the tanks were airlifted back to the EOD Pad where they were refueled and redeployed to these ponds. As there are more remote ponds than fuel tanks, three 900-L double-walled tanks were purchased for use at sites that do not require as much fuel. These tanks, when filled with about 800 L of diesel

fuel, will be airliftable using the contract Huey.

In late August, the systems were shut down and the components retrograded by helicopter to shore. Pipe was once again flown out with a commercial Huey and the heavy equipment was flown out with a Blackhawk (Fig. III-1-10). The total flight time required to remove the five offshore systems, plus the two 1,900-L double-walled fuel tanks, was less than 2.5 hours. All equipment, except the pumps, gensets, fuel tanks, and hose, is being stored on the EOD Pad adjacent to the Flats. The remainder of the equipment is being stored in a yard on post. The hose is under cover to prevent ultraviolet radiation damage.

RESULTS

Results for this season's effort can be measured two ways. The first is how dry we were able to keep the areas, and how quickly they were drained after flooding. The second is how much the natural attenuation was enhanced, as measured by planted particles and composite sampling. Through the use of the tide gates, flooding of Area C was almost pre-

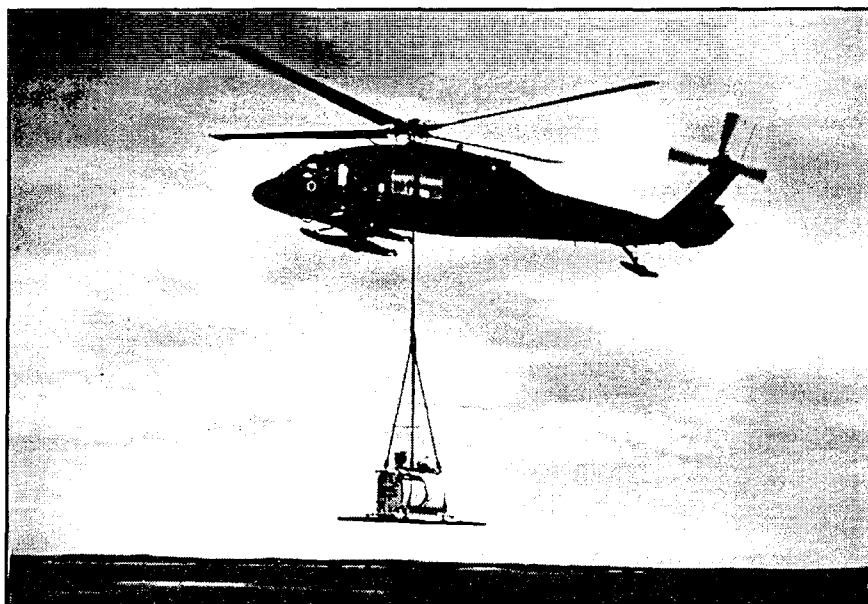

Figure III-1-9. Transporting fuel to remote pump site.

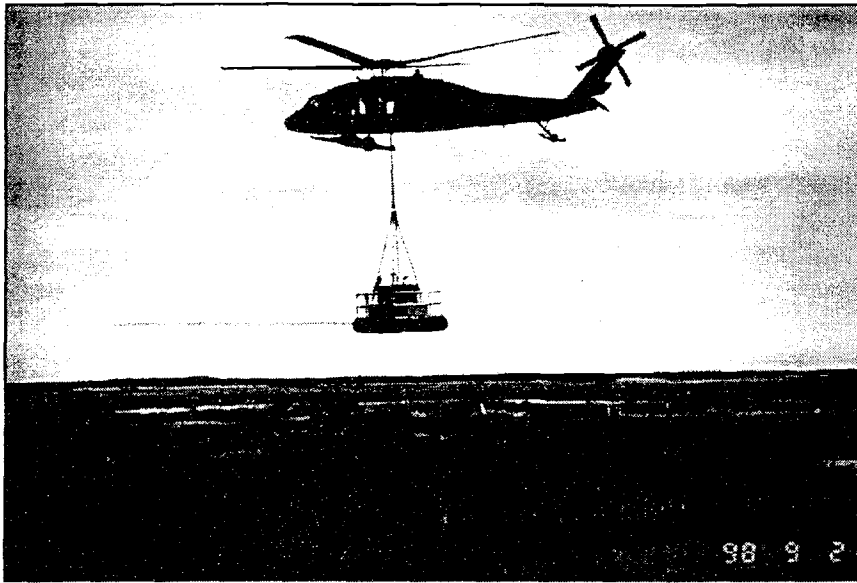

Figure III-1-10. UH-60L Blackhawk helicopter with genset.

vented throughout the core season (15 May to 15 September). After the final flooding tide of the spring, on 28 May, the area was allowed to drain for a day and the pump systems started. The area was drawn down by 1 June. The pump system in Pond 155 was started on 1 June and the pond was drawn down within 1 day. Pond 146 was never completely drained because pump unit 3 lacked a sump and it was recharged from a beaver channel near Clunie Point. Only one flooding tide, that on 10 August, affected the area adversely. Because the contractor had allowed the genset in Pond 183 to run out of fuel, the flooding was widespread. However, it was quickly addressed after refueling, and the wetting was not thorough. Area A, once drained, did not reflood until the resumption of high flooding tides on 6 September. The longest continuous non-flooding periods for the various ponds are listed in Table III-1-2.

Table III-1-2 does not tell the complete story. As can be seen in Figure III-1-11, operation and maintenance problems with some of the equipment prevented the full utilization of the non-flooding period. A potential "dry" period of 70 days has been reduced to three periods of approximately 2 weeks each. Although similar problems occurred with the

other systems, none were as widespread as with system 3.

Figure III-1-11 also shows the relationship between Area C/D and Area A. Although a constant stream of water flowed through a well-developed beaver channel from the direction of C/D to Pond 146, the water does not seem to originate from the C/D ponds. The separation of these two areas was previously hypothesized and is now confirmed.

A final factor in the dryness of the areas drained is the weather. The summer of 1998 was one of the wettest on record, with espe-

Table III-1-2. Maximum non-flooding periods.

Pond	Start*	Flood	Days not flooded
Area C			
146	1 June**	10 August	71
155	2 June	10 August	70
183	1 June	10 August	71
Area A			
256	26 June	5 September	72
258	29 June	5 September	69
290	29 May	5 September	100

*Start date is when pond has been pumped down but not evaporated (except Pond 146).

**Restarted after flood tide.

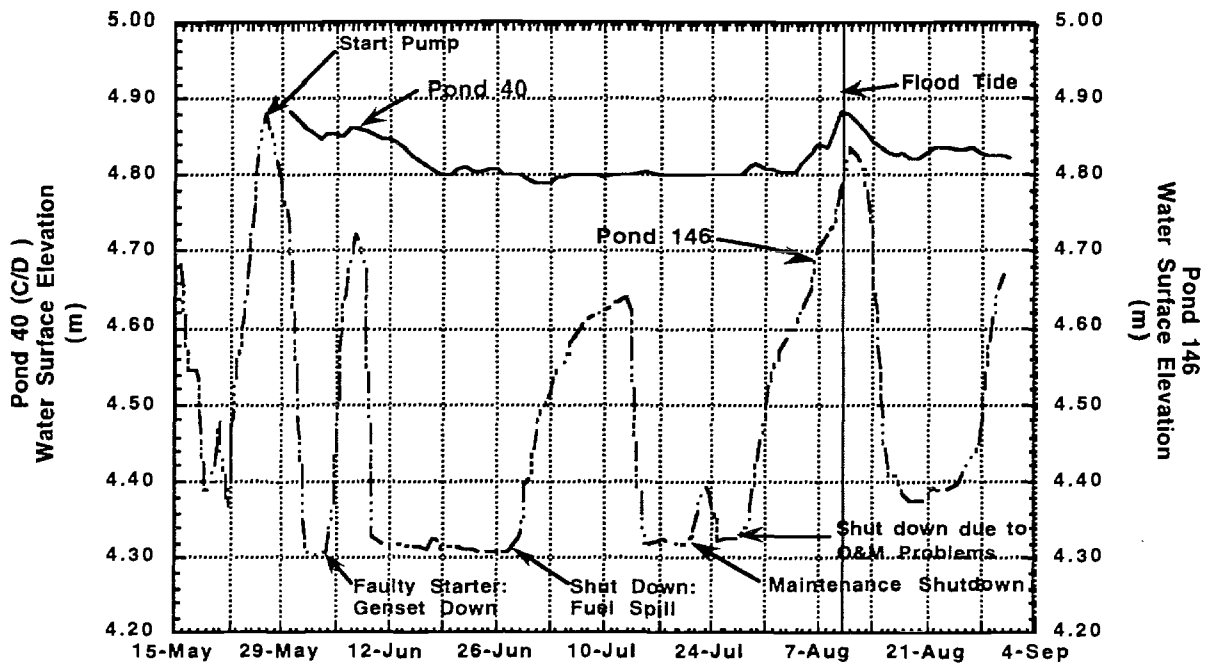

Figure III-1-11. Water level relationships between Area C and Area C/D.

cially heavy rainfall in the months of May and June, normally the driest months of the core season. The May flooding tides eliminated any effective drying that month, and June was one of the wettest on record, with well over twice the normal rainfall. In addition, temperatures were below normal for July and August, and skies were cloudy for almost the entire 3 months from June through August. Table III-1-3 is a synopsis of the relevant climatic conditions for June, July, and August (see also Collins et al., this volume).

One of the tasks we were unable to accomplish this season was measurement of flow through the discharge lines. Without this, we are unable to determine how much water was pumped out of the ponds during the course

of the summer. A rough estimate can be made on those systems with operational timers and counters, and rougher estimates can be made on those systems without. Table III-1-4 contains these estimates.

CONCLUSIONS

Remediation of white phosphorus through enhanced natural attenuation using controlled pumping is both feasible and effective. Wide areas, including multi-pond systems, can be addressed with the minimum of disruption to the physical ecosystem. Biological impacts have not been monitored long enough to determine the effect of temporary

Table III-1-3. 1998 Climatic data for Anchorage and ERF.

Month	Rainfall (mm)			Temperature (°C)			Clear skies or scattered clouds
	Normal	1998	ERF '98	Normal	1998	ERF '98	
June	28.96	68.58	104.15	12.4	12.6	12.0	4 days
July	43.43	25.65	68.42	14.7	14.0	13.2	5 days
August	61.98	82.55	170.25	13.5	12.1	11.0	2 days

Table III-1-4. Estimates of water volumes pumped.

System	Pond	Startup date	Theoretical capacity (m ³ /hr)	Initial drawdown (m ³)	Seasons operation (m ³)
1	183	1 June	450	300	40,000
2	258	25 June	450	9,200	16,000
3	146	27 May	680	80,000	215,000
4	256	23 June	450	15,000	66,000
5	290	28 May	450	2,400	11,000
6	155	1 June	230	200	15,000

Note: 1 m³ = 264 U.S. gallons. 1233 m³ = 1 acre-foot.

pond draining, but vegetation in drained areas does seem to be affected (see Racine et al., this volume).

It is necessary to have a trained crew to perform normal operations and maintenance work on the systems to ensure that equipment downtime is minimized. A refueling failure in August resulted in unnecessary widespread flooding in Area C. A misunderstanding of the basic operation of the switches led to a 3-week shutdown of system 3. It is critical for the effectiveness of this remediation strategy that the equipment be operational throughout the season.

The contract helicopter operations worked out quite well. We were fortunate to have an experienced, cautious pilot who knew his way around the Flats and was able to meet all our needs. If we continue with contracted helicopter operations, we recommend that the same pilot be used.

Finally, the contract UXO operations were once again essential to our work. The person we had the last 2 years and most of this year, Sherry Butters, worked out extremely well. Unfortunately, personnel problems led to her resignation around mid-year, and the company had difficulty filling the position at first. Operations were disrupted for a short time, and although most of the personnel brought in to cover for the job worked out well, one individual left the Flats during a field deployment without contacting any of the field members. This was in clear violation of his responsibility as the site safety officer and could have led to the shut down of the range.

RECOMMENDATIONS

The key element to success of this methodology is keeping the equipment operating. This is especially critical during periods of flooding tides and heavy rains. The six units deployed in 1998 were almost too many to handle at Eagle River Flats, owing to their remote locations. The presence of unexploded ordnance made access difficult and time consuming. Use of a helicopter sped operations immensely, but may not be feasible over the course of a full season because of cost. The lack of experience and initiative of the contract monitoring personnel also affected the effectiveness of this year's effort. More qualified personnel will be needed in the future if the success of this operation is to be assured. Because of a flagrant violation of range safety rules and personnel problems, it is recommended that another UXO contractor be used next field season.

Overall, of all the remediation methods tried at the Flats, pumping seems to be the best alternative when both efficiency and impact are considered. Further use of the pump systems for remediation of white phosphorus at the Flats is therefore recommended.

REFERENCES

Collins, C.M., M.T. Meeks, M.R. Walsh, M.E. Walsh, and R.N. Bailey (1997) Pond draining treatability: 1996 studies-the draining of Bread Truck Pond. In Interagency Expanded

- Site Investigation: Evaluation of White Phosphorus Contamination and Potential Treatability at Eagle River Flats, Alaska (C.M. Collins, and D. Cate Eds.). FY96 Final Report. CRREL Contract Report to U.S. Army, Alaska, Directorate of Public Works, July, p. 51-71.
- Collins, C.M., E.F. Chacho, Jr., M.R. Walsh, and M.E. Walsh** (1996) Pond draining treatability: 1995 studies. In Interagency Expanded Site Investigation: Investigation of White Phosphorus Contamination and Treatability at Eagle River Flats, Alaska (D.W. Cate, and C.H. Racine Eds.). FY 95 Final Report. CRREL Contract Report to U.S. Army Alaska, Directorate of Public Works, September, p.267-309.
- Lawson, D.E., L.E. Hunter, S.R. Bigl, B.M. Nadeau, P.B. Weyrick, and J.H. Bodette** (1996) Physical system dynamics and white phosphorus fate and transport, 1994, Eagle River Flats, Fort Richardson, Alaska. CRREL Report 96-9. USA Cold Regions Research and Engineering Laboratory.
- Racine, C.H., M.E. Walsh, C.M. Collins, D.J. Calkins, and B.D. Roebuck** (1992) Waterfowl mortality in Eagle River Flats, Alaska: The role of munitions residues. CRREL Report 92-5. USA Cold Regions Research and Engineering Laboratory.
- Racine, C.H., M.E. Walsh, C.M. Collins, S. Taylor, B.D. Roebuck, L. Reitsma, and B. Steele** (1993) White phosphorus contamination of salt marsh sediments at Eagle River Flats, Alaska. CRREL Report 93-17. USA Cold Regions Research and Engineering Laboratory.
- Walsh, M.E., C.M. Collins, and C.H. Racine** (1995) Persistence of white phosphorus particles in sediment. CRREL Report 95-32. USA Cold Regions Research and Engineering Laboratory.
- Walsh, M.R., and C.M. Collins** (1998) Dredging as remediation for white phosphorus contamination at Eagle River Flats, Alaska. CRREL Report 98-5. USA Cold Regions Research and Engineering Laboratory.
- Walsh, M.R., E.J. Chamberlain, K.S. Henry, D.E. Garfield, and E. Sorenson** (1996) Dredging in an active artillery impact area: Eagle River Flats, Alaska. Special Report 96-22. USA Cold Regions Research and Engineering Laboratory.
- Walsh, M.R., C.M. Collins, and D.J. Lambert** (1998) Implementation of a remote pumping system for white phosphorus remediation in Pond 183. In Interagency Expanded Site Investigation: Investigation of White Phosphorus Contamination and Treatability at Eagle River Flats, Alaska (C.M. Collins, and D.W. Cate, Eds.). FY 97 Final Report. CRREL Contract Report to U.S. Army Alaska, Directorate of Public Works, August, p. 81-100.

APPENDIX III-1-A: RELAY LOGIC REDESIGN OF CONTROLS FOR PUMP SYSTEMS 2 THROUGH 5

System operation

During normal pumping operations, two of the float switches control the state of the pump. One switch, the low water switch, is attached to the pump and therefore is influenced by both the height of the water in the sump as well as the relationship of the pump pontoons to the bottom of the sump. The second switch, the high water switch, is mounted adjacent to the sump and is thus influenced solely by the sump water level. The low water switch is triggered when the sump starts to refill after pumping down, while the high water switch triggers when the sump fills. When both switches trigger, the genset starts, warms up, and engages the pump. When the sump is partially drawn down, the high water switch is lowered with the water level and triggers off. The pump continues running while the pump pontoons ground at the bottom of the sump and the water level is drawn down below their normal floatation level. As the water falls in relationship to the pontoons and low water float switch, the float switch falls until it triggers off and the genset sends a signal to stop the pump. The genset then runs through a cool-down cycle and shuts down while the sump proceeds to refill (see Fig. III-3-A1).

Problem definition

The original circuitry left the relays latched that enabled the pump to resume operation. If the generator warm-up timer was set to less than the set cool-down cycle time, the pump would reinitiate operation. When the cool-down cycle was completed, the whole system shut down.

Solution

The pump control relay circuitry was examined to determine the cause of the problem. When the cause became apparent, several alternatives were developed. The best alternative required the rewiring of most of the relays involved in the circuit and the removal of one relay altogether. The relay that enables pump operation is now disabled if the low water switch even momentarily triggers off. Copies of the circuitry before and after the modifications follow.

Implementation

Changes were made to systems 2 through 6 in late June. All systems were tested prior to our departure to ensure proper operation.

Outcome

All systems successfully ran without a repetition of the restart problem through the remainder of the field season.

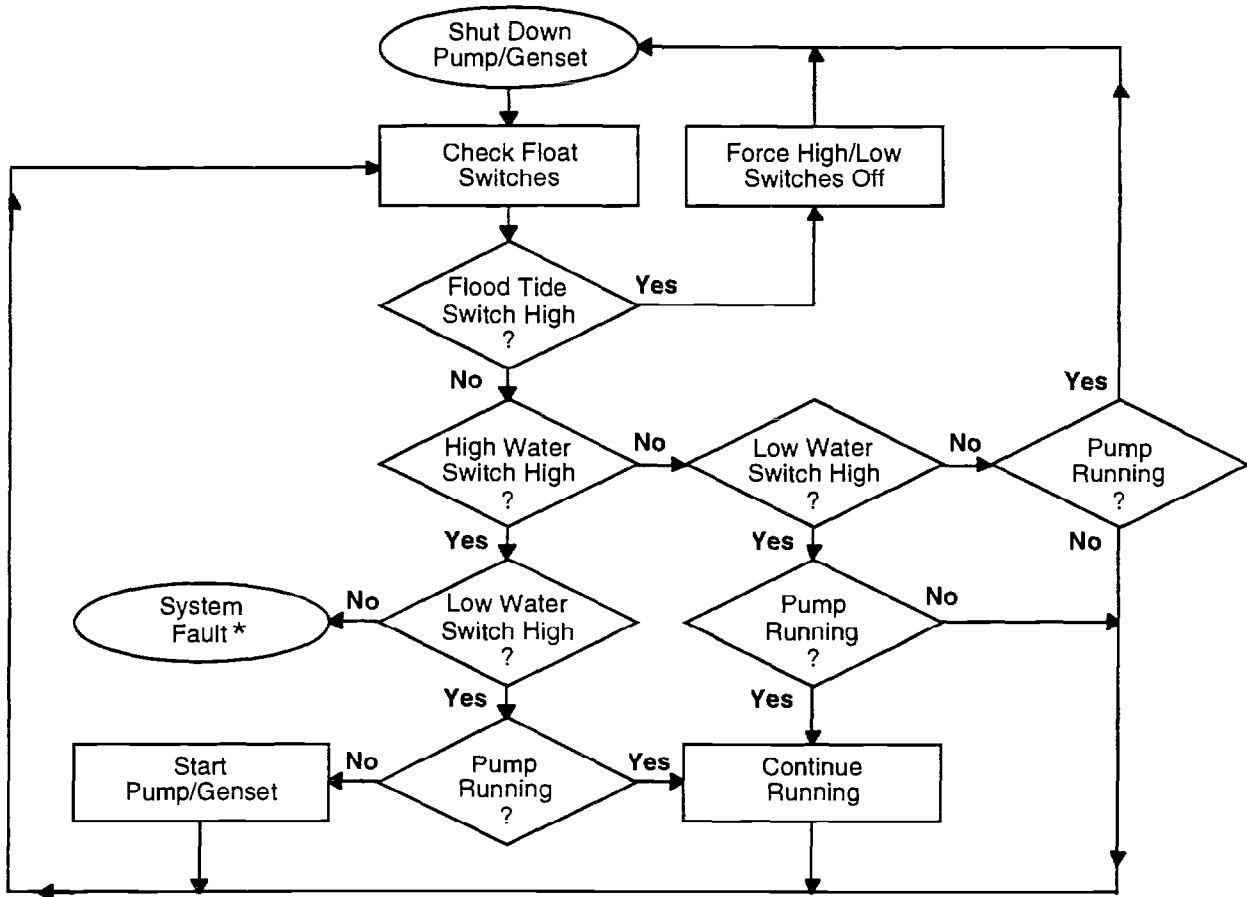

* System Faults include faulty switches or logic elements. Field service required to rectify.

Figure III-1-A1. Switch logic diagram for all pump systems at Eagle River Flats. System 3 slightly different owing to the selectable tandem pump arrangement.

Original switch logic: pump systems 4 through 6

WATER RAISES TO MAKE LOW WATER SWITCH LS-1

LS-1 Makes

CR-3 Energizes

CR-3 (1-4) Opens, blocking CR-4

CR-3 (5-6) Opens in CR-5 circuit, blocking CR-2 (1-3) bypass

CR-3 (11-9) Closes

WATER RAISES TO MAKE HIGH WATER SWITCH LS-2

Strobelight #2 "A" activated

TD-1 Starts: Genset start delay

TD-1 Times out / Energizes

TD-1 (1-4) Opens

TD-1 (1-3) Closes

CR-1 Energizes

CR-1 (1-3) Closes, bypassing LS-2

CR-1 (6-7) Closes: *Generator starts*

CR-1 (9-11) Closes on CR-4 circuit (CR-4 Stays low)

CR-8 Energizes

CR-8 (13-14) Closes

TD-2 Starts: *Genset warm-up***TD-2 Times out / Energizes**

TD-2 (1-4) Opens

Strobelight #1 "A" deactivated

TD-2 (8-6) Closes

CR-2 Energizes

CR-2 (1-3) Closes on CR-5 circuit (CR-5 stays low)

CR-2 (6-7) Closes

Run Time Meter starts / Green indicator light activates / Cycle counter starts index

Magnetic contactor **M energizes****Contacts M Close—Pump starts**

M (13-14) Closes

Strobelight #1 "R" activates

WATER FALLS TO OPEN HIGH WATER SWITCH LS-2

No change in status of CR-1 due to CR-1 (1-3)

Pump continues running

WATER FALLS TO OPEN LOW WATER SWITCH LS-1**CR-3 De-energizes**

CR-3 (5-6) Closes, bypassing CR-2 (1-3) (CR-5 stays low)

CR-3 (11-9) Opens

TD-2 De-energizes

TD-2 (1-4) Closes: No strobe due to CR-5 (1-4) below.

TD-2 (8-6) Opens

CR-2 De-energizes

CR-2 (6-7) Opens

Light "G" deactivates / RTM stops / CC completes index

M De-energizes**Contacts M Open—Pump stops**

M (13-14) Opens

Strobelight #1 "R" deactivates

CR-2 (1-3) Opens.

CR-3 (1-4) Closes

CR-4 Energizes

CR-4 (1-3) Closes

CR-5 Energizes

CR-5 (11-9) Closes, bypassing CR-4 (1-3)

CR-5 (5-6) Opens, reinforcing CR-2 (6-7). Pump already off.

CR-5 (1-4) Opens

TD-1 De-energizes

TD-1 (1-3) Opens

TD-1 (1-4) Closes. No strobe activation.

CR-1 De-energizes

CR-1 (1-3) Opens, removing LS-2 bypass.

CR-1 (9-11) Opens

CR-4 De-energizes

CR-4 (1-3) Opens (CR-5 remains on due to CR-5 [11-9])

CR-1 (6-7) Opens (Generator Start/Run circuit)

Generator goes into automatic cool-down mode (Generator controls)

Generator shuts down

CR-8 De-energizes

CR-8 (13-14) Opens

EXCEPT FOR CR-5, ALL CONTROLS AT BASE STATE

WATER TRIGGERS LS-1 BEFORE END OF COOL-DOWN CYCLE

CR-8, CR-5 Still Energized

CR-3 Energized

CR-3 (1-4) Opens (CR-4 already low)

CR-3 (5-6) Opens

CR-5 De-energizes

CR-5 (1-4) Closes (CR-1 remains low)

CR-5 (5-6) Closes

CR-5 (11-9) Opens

CR-3 (11-9) Closes

TD-2 Starts

IF TD-2 < REMAINING COOL DOWN TIME:

TD-2 Times out / Energizes

TD-2 (8-6) Closes

CR-2 Energizes

CR-2 (6-7) Close

M Energizes

Light "G" activates / RTM Starts / CC Initiates

M (13-14) Close

Strobelight #1 activates

Contacts M Make. Two scenarios possible:

PUMP RUNS UNTIL COOL DOWN CYCLE FINISHES

Genset stops running – Cool down cycle complete

CR-8 De-energizes

CR-8 (13-14) opens

CR-2 De-energizes

CR-2 (6-7) Opens (Pump already off – Genset has stopped)

SYSTEM IN BASE STATE

OR: PUMP RUNS UNTIL LS-1 OPENS AGAIN

CR-3 De-energizes

CR-3 (11-9) opens

CR-2 De-energizes

CR-2 (6-7) Opens

Light "G" deactivates / RTM stops / CC completes index

M De-energizes

Contacts M Open—Pump stops

M (13-14) Opens

Strobelight #1 "R" deactivates
 Genset stops running – Cool down cycle complete
 CR-8 De-energizes
 CR-8 (13-14) opens

SYSTEM IN BASE STATE

IF TD-2 > REMAINING COOL DOWN TIME:

Generator shuts down before TD-2 Energizes
 CR-8 De-energizes
 CR-8 (13-14) Opens
SYSTEM IN BASE STATE

FLOOD WATER ACTIVATES SWITCH LS-3

CR-6 Energizes

Light "B" activates

CR-6 (5-6) Opens

CR-3 De-energizes

CR-3 (1-4) Closes (CR-1 (9-11) Opens at same time) CR-4 remains off

CR-3 (5-6) Closes. CR-5 remains off

CR-3 (11-9) Opens

CR-2 De-energizes

CR-2 (6-7) Opens

M De-energizes

Pump stops

CR-6 (4-1) Opens

TD-1 De-energizes

CR-1 De-energizes

CR-1 (1-3) Opens

CR-1 (9-11) Opens, blocking CR-4 and thus CR-5

CR-1 (6-7) Opens

Automatic shutdown cycle initiated

CR-8 De-energizes

Generator shutdown cycle completes

Generator stops

CR-8 De-energizes

CR-4 and CR-5 never become energized.

Figure III-3-A2 gives the original circuit diagram.

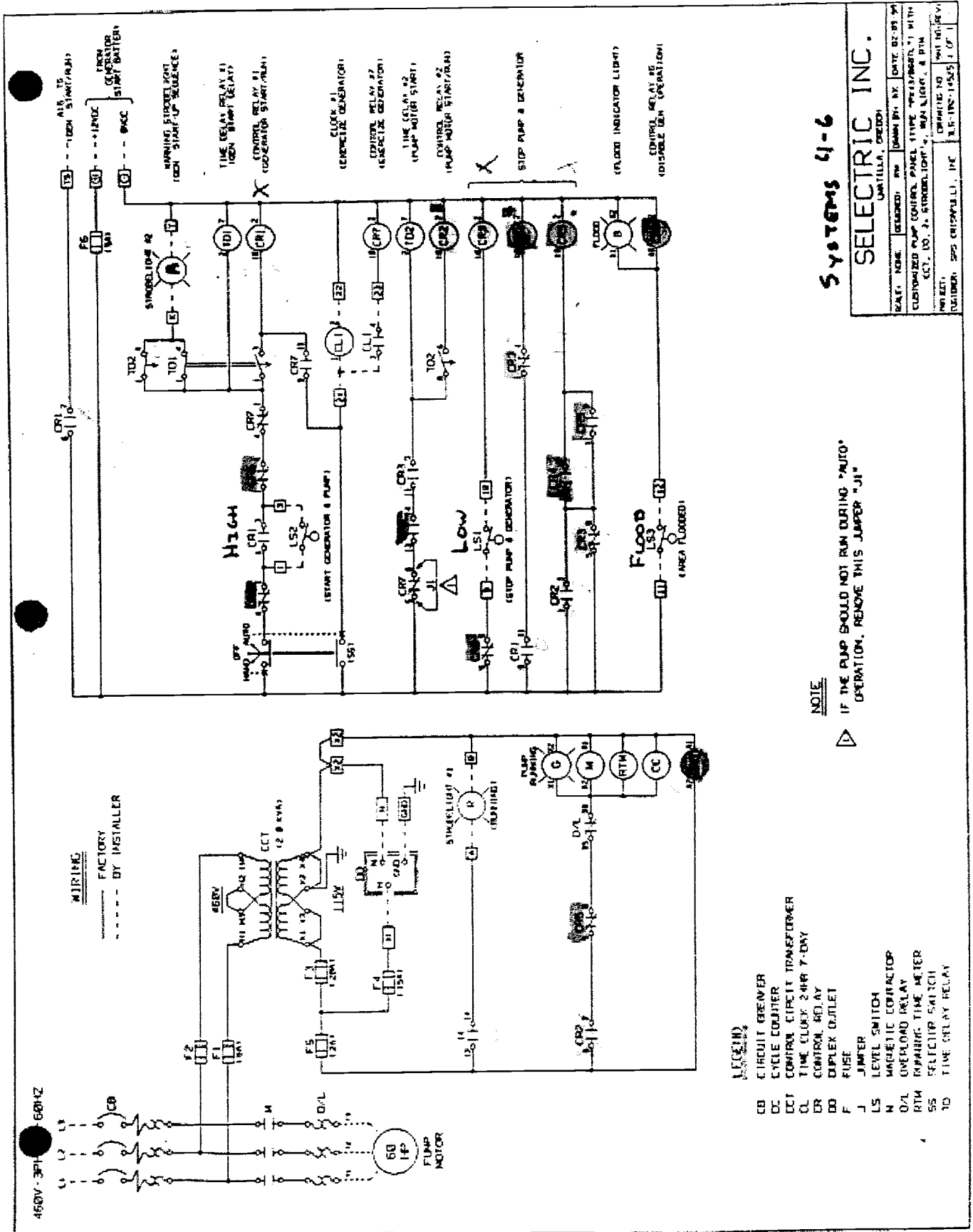

Figure III-1-A2.

Revised switch logic: pump systems 2 and 4 through 6 (MOD II)

WATER RAISES TO MAKE LOW WATER SWITCH LS-1

CR-3 Energizes

- CR-3 (1-3) Closes
- CR-3 (11-9) Closes
- CR-3 (6-7) Closes

WATER RAISES TO MAKE HIGH WATER SWITCH LS-2

Strobelight #2 activates

TD-1 Energizes (Start delay circuit)

TD-1 Times out / Latches

- TD-1 (1-4) Opens (Strobelight #2 remains on)
- TD-1 (1-3) Closes

CR-1 Energizes

- CR-1 (6-7) Closes
- Generator starts

CR-8 Energizes

- CR-8 (13-14) Closes

CR-1 (9-11) Closes

CR-4 Energizes

- CR-4 (1-3) Closes (LS-2 bypassed)

CR-1 (1-3) Closes

TD-2 Energizes (Generator warm-up)

TD-2 Times out / Latches

- TD-2 (1-4) Opens
- Strobelight #2 deactivates
- TD-2 (6-8) Closes

CR-2 Energizes

- CR-2 (6-7) Closes
- G, RTM, and CC Activated

Contactor M Energizes

- M (13-14) Close
- Strobelight # 1 activates
- Pump contacts M close
- Pump starts*

WATER FALLS TO OPEN HIGH WATER SWITCH LS-2

No change in status of relays due to CR-4 (1-3)

Pump continues running

WATER FALLS TO OPEN LOW WATER SWITCH LS-1

CR-3 De-energizes

- CR-3 (6-7) Opens
- G, RTM, and C Deactivate

Contactor M De-energizes

- M (13-14) Open
- Strobelight #1 deactivates
- Contacts M Open—*Pump stops*

CR-3 (11-9) Opens

TD-2 De-energizes
 TD-2 (1-4) Closes
 TD-2 (8-6) Opens
CR-2 De-energizes
 CR-2 (6-7) Opens (Pump already off)
 CR-3 (1-3) Opens
CR-4 De-energizes
 CR-4 (1-3) Opens
CR-1 De-energizes
 CR-1 (1-3) Opens
 CR-1 (9-11) Opens
 CR-1 (6-7) Opens
 Automatic cool-down cycle initiates
 Automatic cool-down cycle completes
 Genset stops running
CR-8 De-energizes
 CR-8 (13-14) Opens
BASE STATE

WATER TRIGGERS LS-1 BEFORE END OF COOL-DOWN CYCLE

CR-3 Energizes
 CR-3 (6-7) Closes
 Pump remains off due to CR-2 (6-7)
 CR-3 (1-3) Closes
 CR-4 remains off due to CR-1 (9-11)
 CR-3 (11-9) Closes
 CR-2 remains off due to CR-1 (1-3)
Pump remains off through cool-down cycle

FLOOD WATER ACTIVATES SWITCH LS-3

CR-6 Energizes
 Light "B" activates
 CR-6 (5-6) Opens
CR-3 De-energizes
 CR-3 (6-7) Opens
 G, RTM, and C Deactivate
Contactors M De-energizes
 M (13-14) Open
 Strobelight #1 deactivates
 Contacts M Open
Pump stops
 CR-3 (11-9) Opens
TD-2 De-energizes
 TD-2 (8-6) Opens
 TD-2 (1-4) Closes
CR-2 De-energizes
 CR-2 (6-7) Opens (Pump already off)
 CR-3 (1-3) Opens
CR-4 De-energizes
 CR-4 (1-3) Opens

TD-1 De-energizes

TD-1 (1-4) Closes

TD-1 (1-3) Opens

CR-1 De-energizes

CR-1 (1-3) Opens

CR-1 (9-11) Opens

CR-1 (6-7) Opens

Start auto-shutdown cycle

End auto-shutdown cycle

Generator stops

CR-8 De-energizes

CR-8 (13-14) Opens

CR-6 (4-1) Opens

QUASI-BASE STATE

Figure III-1-A3 gives the revised circuit diagram.

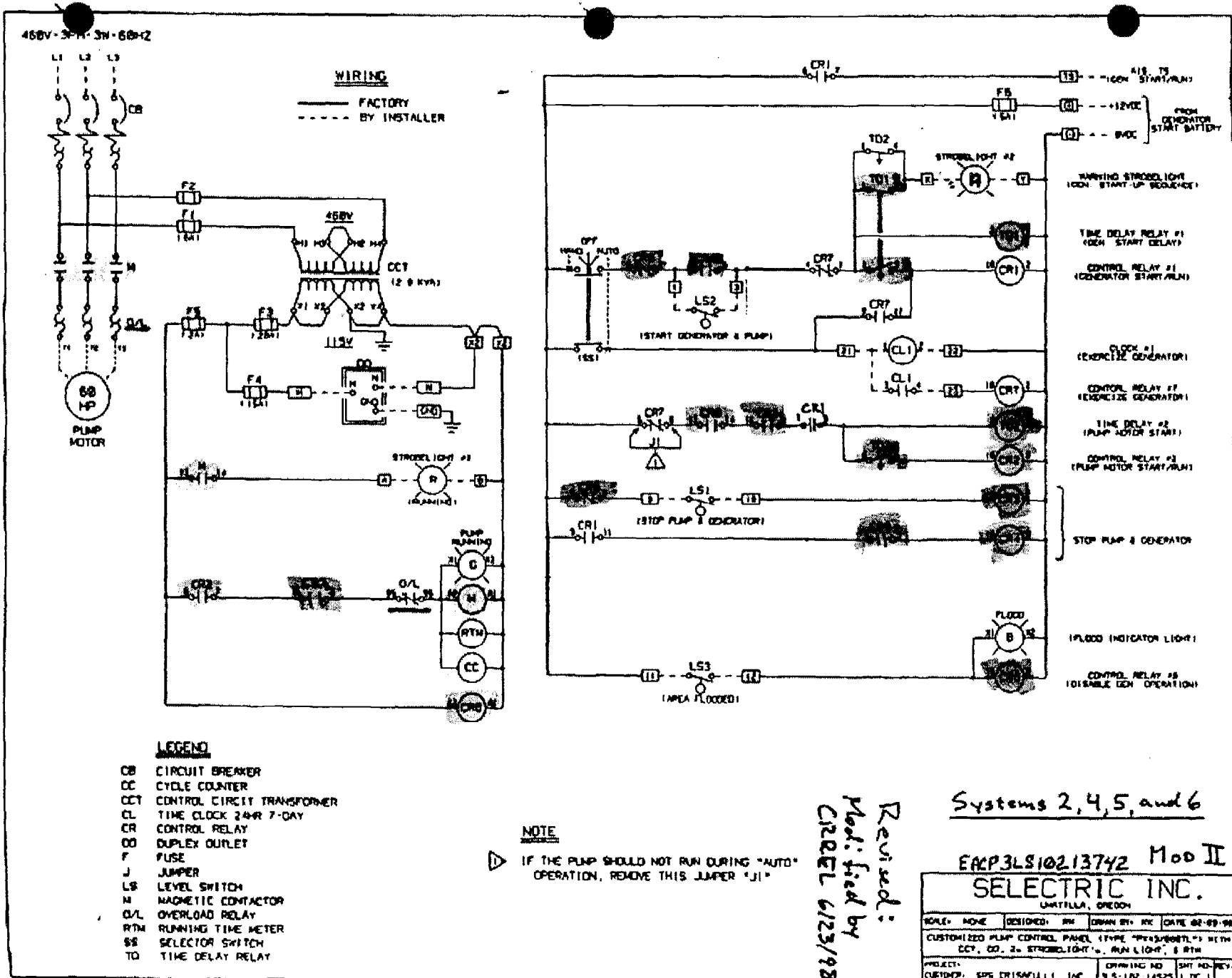

Figure III-1-A3.

APPENDIX III-1-B: SYSTEM DISCHARGE LINE COMPOSITIONS

This year's deployment of six systems was a challenge in more than one respect. We had little knowledge of the interconnectivity among the new ponds we were tasked to address and the contiguous areas adjacent to them. In some cases, we were not sure where the best route to run the discharge lay. Based on last year's experience, we deployed system 1 in Pond 183 with predominantly 25-cm diameter pipe. System 3, in Pond 146, was fitted predominantly with 30-cm pipe, and system 6, in Pond 155, was fitted with 20-cm pipe. When system 5 was deployed in Pond 290, we were unsure of the volume to be pumped and the possibility of recharge, so it was fitted with a ratio of 25- to 20-cm pipe of about 3.5 to 1. At the time, we were not sure about the discharge distances for Ponds 256 and 258.

In late June, systems 2 and 4 were installed in Ponds 258 and 256, respectively. At this time, very little 25-cm pipe remained, so we resorted to using 20-cm pipe for the majority of the runs. After we got these systems on line, it became obvious that the volumes to be pumped and the degree of interconnectivity for these two ponds was quite high, and future deployments should maximize the use of 25-cm pipe. System 5, on the other hand, ran very little, as Pond 290 had a low recharge rate and was relatively isolated from the surrounding intermittent ponds. System 1 in Pond 183 only ran sporadically because the majority of the water was handled by system 3 in interconnected Pond 146. When the pumps are redeployed in Ponds 183 and 290, they should be fitted with 20-cm lines next season; the 25-cm lines should be reserved for the systems in Ponds 256 and 258. Table III-3-B1 gives the discharge line composition for each of the systems deployed this year. Table III-3-B2 provides the proposed deployment configurations for next year.

Table III-3-B3 summarizes the specifications of all six systems. It includes pump types and sizes; genset model numbers, sizes, and fuel capacities; weights of each unit; and estimated fuel consumption rates. Also included is maintenance information such as filter model numbers, and maintenance notes.

III-1. REMOTE PUMPING SYSTEMS

Table III-1-B1. Actual configuration for 1998 deployment.

Pond	Pump system	Capacity (L/s)	20 cm	25 cm	30 cm	Other
183 Area C	1	125	1 × 6.1-m pipe 1 × 3-m hose 1 × 7.6-m hose —	50 × 6.1-m pipe 2 × 1.5-m pipe 1 × 3-m pipe 1 × 7.6-m hose	— — — —	20-cm (F) to 25-cm (M) adapter 20-cm check valve — —
258 Area A	2	125	1 × 3-m hose 2 × 7.6-m hose 1 × 1.5-m pipe 39 × 6.1-m pipe	— — — —	— — — —	— — — —
146 Area C	3	62/125/186	— — —	2 × 1-m pipe 7 × 6.1-m pipe —	2 × 6.1-m hose 2 × 3-m pipe 71 × 7.6-m pipe	25-cm (F) to 20-cm (M) adapter — —
256 Area A	4	125	1 × 3-m hose 3 × 7.6-m hose 53 × 6.1-m pipe	8 × 6.1-m pipe — —	— — —	20-cm (F) to 25-cm (M) adapter 25-cm (F) to 20-cm (M) adapter —
290 Area A	5	125	1 × 3-m hose 1 × 7.6-m hose 5 × 6.1-m pipe	1 × 3-m pipe 23 × 6.1-m pipe —	— — —	20-cm check valve 20-cm (F) to 25-cm (M) adapter 25-cm (F) to 20-cm (M) adapter
155 Area C	6	62	1 × 3-m hose 1 × 7.6-m hose 1 × 3-m pipe 49 × 6.1-m pipe	— — — —	— — — —	20-cm check valve — — —

Table III-1-B2. Proposed configuration for 1999 deployment.

Pond	Pump system	Pump capacity (L/s)	20 cm	25 cm	30 cm	Other
183 Area C	1	125	53 × 6.1-m pipe 1 × 3-m hose 1 × 3.8-m hose 1 × 7.6-m hose	— — — —	— — — —	20-cm check valve — — —
258 Area A	2	125	1 × 3-m hose 1 × 7.6-m hose	39 × 6.1-m pipe —	— —	20-cm check valve —
146 Area C	3	62/125/186	— — —	2 × 3.8-m hose 5 × 6.1-m pipe	1 × 6.1-m hose 2 × 3-m hose 2 × 3-m pipe 73 × 7.6-m pipe	25-cm (F) to 20-cm (M) adapter — — —
256 Area A	4	125	1 × 3-m hose 3 × 6.1-m pipe 1 × 7.6-m hose	61 × 6.1-m pipe — —	— — —	20-cm check valve 20-cm (F) to 25-cm (M) adapter —
290 Area A	5	125	1 × 3-m hose 1 × 3.8-m hose 1 × 7.6-m hose 29 × 6.1-m pipe	— — — —	— — — —	20-cm check valve 20-cm (F) to 25-cm (M) adapter 25-cm (F) to 20-cm (M) adapter —
155 Area C	6	62	1 × 3-m hose 1 × 7.6-m hose 1 × 3-m pipe 49 × 6.1-m pipe	— — — —	— — — —	20-cm check valve — — —

EAGLE RIVER FLATS FY 98

Table III-1-B3. System summary.

	System 1	System 2	System 3	System 4	System 5	System 6
PUMPS						
Type	<i>Crisafulli J-series open impeller centrifugal pumps. Float-mounted.</i>					
Size	15.25 cm*	15.25 cm*	15.25/10 cm*	15.25 cm*	15.25 cm*	10 cm**
Discharge	20 cm	20 cm	30 cm	20 cm	20 cm	15 cm
Capacity (max.)	450 m ³ /hr	450 m ³ /hr	680 m ³ /hr	450 m ³ /hr	450 m ³ /hr	230 m ³ /hr
Power	45 kW	45 kW	37/56 kW	45 kW	45 kW	22 kW
Serial number	14253	14598	14704/14711	14712	14714	14703
Est. weight	1360 kg	1360 kg	2500 kg	1360 kg	1360 kg	910 kg
GENSETS						
Engine type	<i>Cummins diesel w/turbocharger mounted to floating platform w/fuel tanks</i>					
Serial number	45122826	45555781	45639608	45638923	45640798	45639566
Model	6BT5.9-G1	6BT5.9-G2	6CT8.3-G	6BT5.9-G2	6BT5.9-G2	6BT5.9-G1
Power (kW)	100	124	154	124	124	66
Generator type	<i>Onan Detector 12 w/Crisafulli-CRREL interface</i>					
Model	80DGDA	80DGDA	12580DGDHA	80DGDA	80DGDA	50DGA
Serial number	A950566145	G970643637	A980678556	A980678561	A980678560	A98067784B
Genset unit S/N	14257	14626	14731	14730	14729	14728
Fuel capacity (L)	946	1022	1893	1325	350	1022
Est. weight (dry)	3260 kg	3260 kg	—	3260 kg	3260 kg	2950 kg
Est. weight (airlift)	3720 kg	3720 kg	—	3720 kg	3720 kg	3720 kg
EFC* (Genset)	16.46	12.21	10.23	9.96	9.46	6.42
EFC (pumping)	29.12	18.93	25.23	17.20	27.04	9.23

*6 in.

**4 in.

III-2. Treatment Verification: Monitoring the Remediation of White Phosphorus Contaminated Sediments of Drained Ponds

Marianne E. Walsh, Charles M. Collins, and Ronald N. Bailey
U.S. Army Cold Regions Research and Engineering Laboratory
Hanover, NH

INTRODUCTION

The success of remediation of the white phosphorus contamination at ERF is monitored in several ways, owing to the complexity of the site and its unconventional contaminant. One component of the monitoring process is to confirm that the amount of white phosphorus in surface sediments is decreasing, thereby becoming less of a threat to waterfowl. Using both composite and discrete samples, we measured white phosphorus concentrations and examined sediment samples for the presence of white phosphorus particles. We also monitored sediment temperature and moisture to determine if conditions were conducive to sublimation-oxidation, and we confirmed whether conditions were favorable or unfavorable by measuring the residue of white phosphorus particles of known mass that we had placed at various points in the drained ponds.

METHODS

Composite sampling

Pond 183 (Area C) and Pond 109 (BT Pond)

In 1997, we established 200-m-long west-east transects in Area C and the Bread Truck Pond to monitor sublimation-oxidation conditions and for baseline and verification sediment sampling (M.E. Walsh et al. 1998). Three transects were established, one in Area C (Ponds 164 and 183) and two in Bread Truck

Pond (Ponds 99 and 109). Along each west-east transect at 0, 50, 100, 150, and 200 m, composite samples were collected to determine if hot spots (localized areas containing white phosphorus particles) were present. Each composite sample was made up of 92 sediment cores obtained at the nodes of a 1.82-m square grid covering a 5.46-m-wide area extending 20 m north and south of the west-east transect. For each of the three transects, the highest white phosphorus concentrations were found in the middle of the ponds (samples taken at the grid 100 m along the transect). In 1998, we resampled these grids (Fig. III-2-1, III-2-2, and III-2-3), and collected five replicate composite samples from each grid at C 100 m, BT South 100 m, and BT North 100 m.

In Area C, 50-mL samples were obtained using a plastic syringe corer (2.65-cm i.d., 9-cm length) as was done in previous years (M.E. Walsh et al. 1997, 1998). Owing to sediment consolidation caused by draining, it was very difficult to insert the plastic corer into the sediment. In the Bread Truck area and other areas, we substituted an Oakfield corer, which has a handle and tapered tip that greatly facilitated its insertion into the consolidated sediment. The corer's internal diameter was 2 cm, and, when a 10-cm-long core was taken, resulted in a 31-mL sediment sample.

Pond 155 (Northern C)

Pond 155 is a small 0.35-ha (0.70-acre) per-

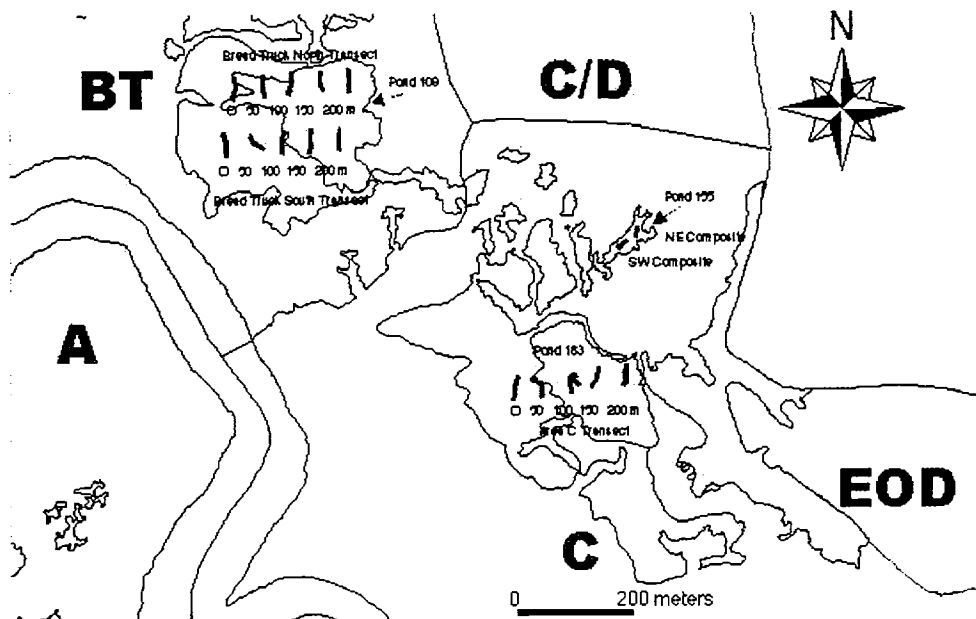

Figure III-2-1. Locations of transects established in 1997 in Area C and the Bread Truck Pond. Grid composites were collected in 1998 at the 100 m sites. Additional grid composites were collected in 1998 in Pond 155.

manent pond located north of the main pond in Area C (Pond 183). This pond was first sampled in 1992, after Daniel Lawson found over 30 waterfowl carcasses in the pond and in the surrounding bulrush. Of the eight sediment samples collected by Charles Racine in

August 1992 from the pond, seven had detectable concentrations of white phosphorus (Racine et al. 1993). In September 1997, a sump was explosively excavated in the middle of this pond, and in June 1998 the pond was pumped. Because this pond was

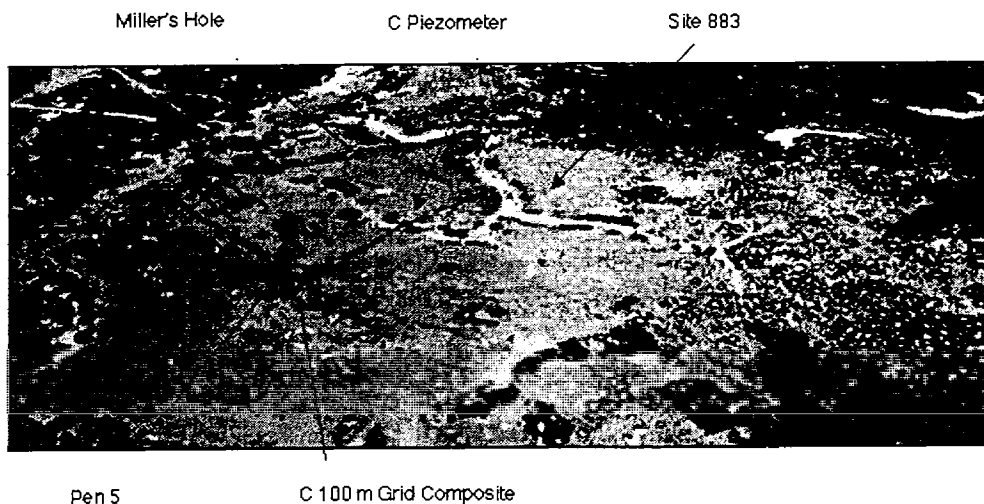

Figure III-2-2. Aerial view from northwest of 1998 sample locations in Area C. The photo was taken on 26 June 1998.

III-2. TREATMENT VERIFICATION

Discrete Samples

BT North 100 m Data Station and Grid Composite



Figure III-2-3. Aerial view of 1998 sample locations in Bread Truck Pond (the aerial photo was taken in 1996).

BT South 100 m Data Station and Grid Composite



Figure III-2-4. Aerial view from west of Pond 155 (Northern C) after pumping. Two grid composites were collected to the southwest and northeast of the sump hole.

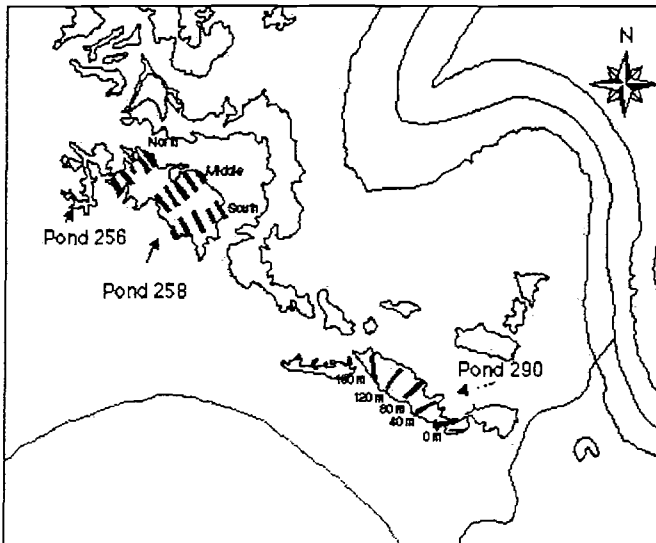

Figure III-2-5. Locations of grid composites in Area A Ponds 290 and 258.



Figure III-2-6. Aerial view from south of Pond 290 (Area A) three weeks after pumping.

relatively small, the sump hole covered a significant portion of what was open water habitat. In August 1998, we collected composite samples from grids covering the remainder of what will be open water habitat when the pond is not pumped (Fig. III-2-4).

Pond 290 (Area A)

Pond 290, formerly called Otter Creek Pond, is located on the west side of ERF in Area A. It is an oval-shaped 0.91-ha (1.82-acre) permanent pond (Fig. III-2-5 and III-2-6). In 1993, Charles Racine collected five discrete samples from this pond, all of which were blank. In 1994, Carl Bouwkamp collected three replicate discrete samples from a point on the north end of the pond, one of which had a reported white phosphorus concentration of 0.0002 $\mu\text{g/g}$, while the other two were blank. Because the method detection limit was 0.00088 $\mu\text{g/g}$, the uncertainty associated with the reported positive sample is high.

In June 1998, we set up a 160-m transect through the long axis of pond 290, based on the design we used in Area C and Bread Truck

Pond. At 0, 40, 80, 120, and 160 m, we collected composite samples by obtaining cores of sediment at the nodes of a 1.82-m square grid covering a 5.46-m-wide area extending 20 m on either side and roughly perpendicular to the transect (Fig. III-2-7). Each grid was sampled in duplicate in June 1998. Additional samples were collected north and south of the transect, and along a line perpendicular to the transect at 140 m (Fig. III-2-7).

Ponds 258 and 256 (Northern A)

Ponds 258 and 256 are located on the west side of ERF in Area A (Fig. III-2-8). Pond 258 is a large pond of 1.72 ha (3.44 acres) where over 50 discrete samples were collected between 1991 and 1994. Sampling was prompted by the large number of waterfowl carcasses that have been found in this pond (70 carcasses in August 1992). Only four samples were positive; the highest concentration found was 0.04 $\mu\text{g/g}$. Several positive samples were collected just north of Pond 258, but again concentrations and frequency of detection were much lower than in Area C,

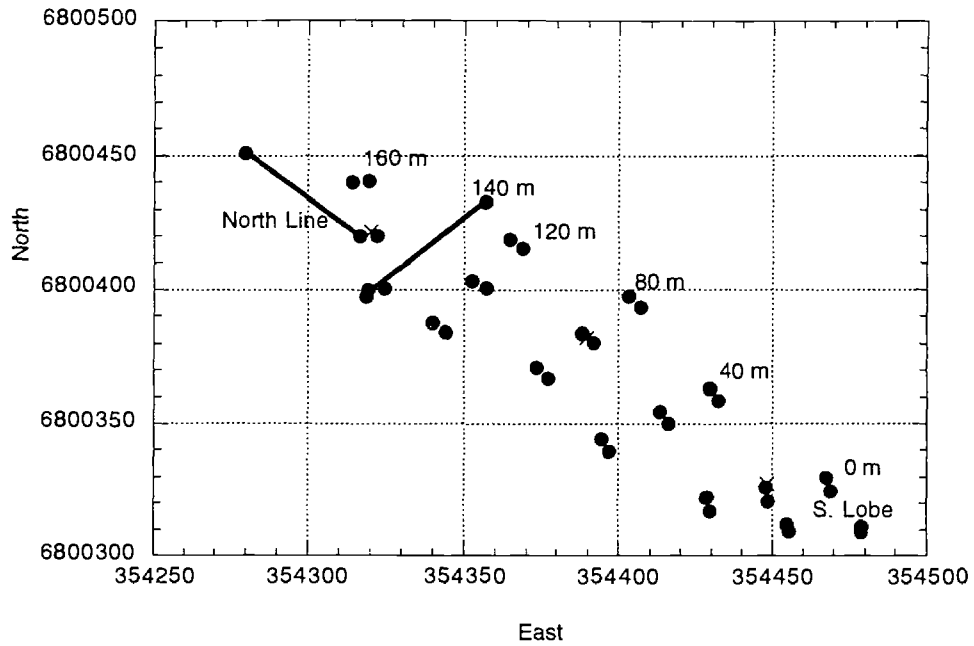

Figure III-2-7. Map of grid and line composites collected from Pond 290.



Figure III-2-8. Aerial view from south of Pond 258 (foreground) and Pond 256 (Area A) three weeks after pumping commenced.

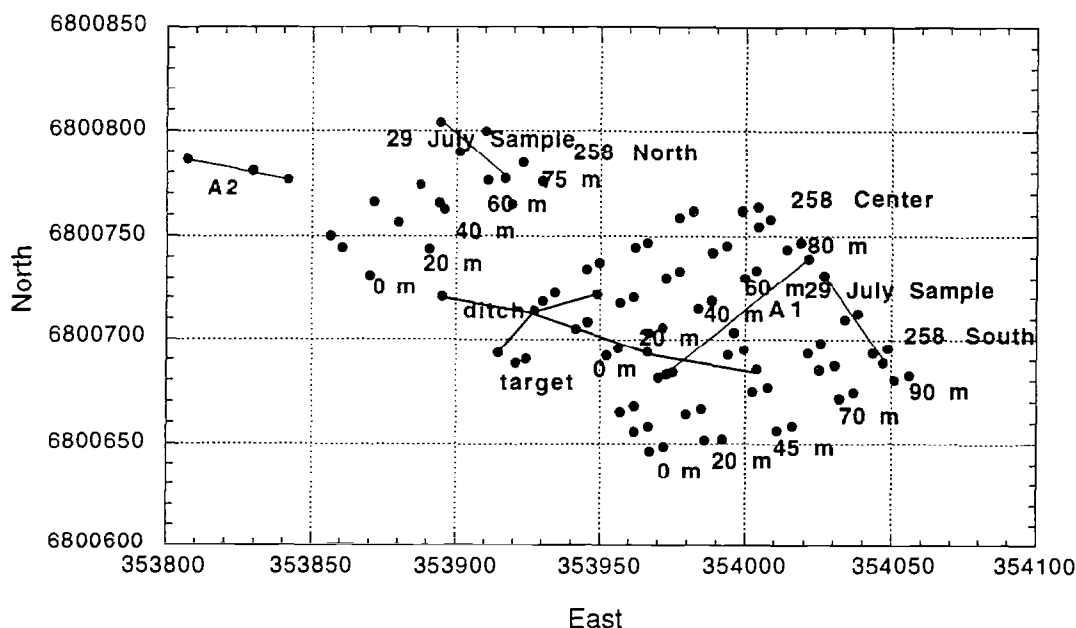

Figure III-2-9. Map of grid and line composites collected from Ponds 258 and 256.

Bread Truck Pond, and Racine Island.

In August 1998, we established three west to east transects labeled 258 south, 258 center, and 258 north (Fig. III-2-5 and III-2-9). The lengths of these transects were 90, 80, and 75 m. Composite samples were collected from the nodes of grids extending south and north of the west to east transects. Because previously collected discrete samples from this pond were predominantly blank or had very low white phosphorus concentrations, we combined fewer subsamples to form our composites to lessen the likelihood of diluting slightly contaminated sediment with uncontaminated sediment. Samples taken on grids north and south of the transects were designated "plus" and "minus," respectively.

We also collected several composite samples by combining subsamples taken at 2-m intervals along lines. Five composites were formed from sediment collected along a drainage ditch along the southwest side of the pond (Fig. III-2-9). One composite was formed from samples taken in a circle around the only target in this pond. Two composites were formed from samples taken along lines running through datalogger stations in Ponds 258 and 256 (labeled A1 and A2). Additional samples were taken between line A1 and the

sump hole in Pond 258 and around the rim of the sump hole after a sandpiper died while feeding along the sump rim. Finally, two composites were formed from subsamples taken along the east side of the pond where previous sampling showed some contamination.

Ponds 293 and 297 (Racine Island)

The small ponds of Racine Island were first sampled in 1993, and severe contamination was found on the west side of the island. One discrete sample had a white phosphorus concentration of over 3000 $\mu\text{g/g}$. Considering that the LD_{50} for mallards is around 3 mg/kg of body weight, just 1 g of sediment would contain enough white phosphorus to kill a dabbling duck. To lessen the likelihood of waterfowl feeding in the contaminated sediment, a drainage ditch was excavated in 1997 to remove standing water.

We collected three composite samples from Racine Island, two from the western end of Pond 293, and one covering Pond 297 (Fig. III-2-10). Draining has significantly changed the pond boundaries on Racine Island, with vegetation replacing areas that were open water. The composite samples were taken by collecting cores at 2-m intervals from either

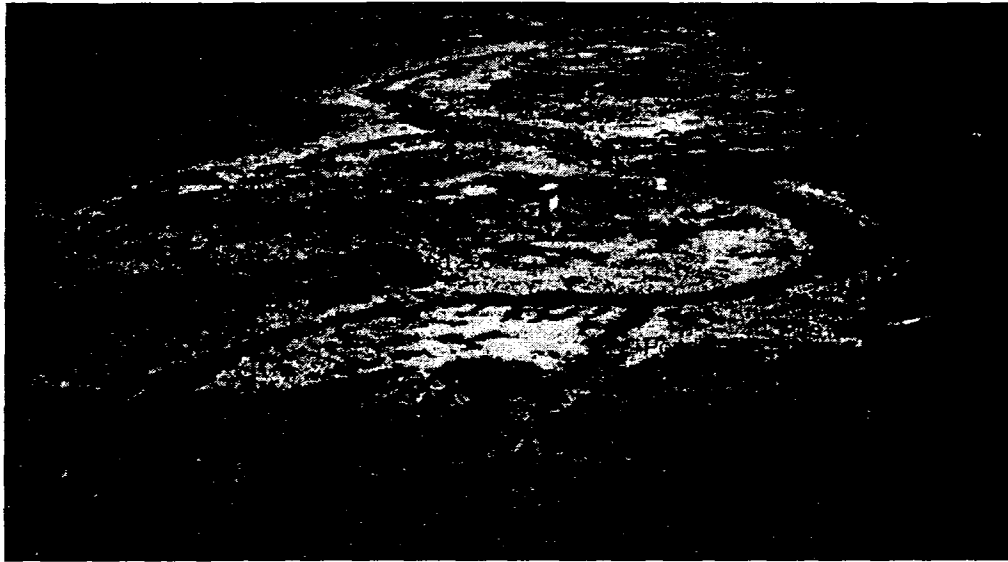

Figure III-2-10. Aerial view from west of Racine Island. Grid composite samples were collected from Ponds 293 and 297.

side of the shallow drainage ditches running through centers of the ponds.

Discrete surface and subsurface sampling

We collected discrete surface and subsurface samples primarily from sites that had high concentrations of white phosphorus prior to drainage of the ponds. We intensively sampled the location of the DWRC Pen 5 in Area C (Fig. III-2-2), used from 1992 to 1993 to evaluate methyl anthranilate. In 1996, we sampled a 5.46- by 20-m area surrounding this pen, taking discrete samples at the nodes of a 1.82-m square grid (M.E. Walsh et al. 1997); we repeated the sampling in 1998 to compare concentrations and to determine if white phosphorus particles are still present in the surface sediment.

Discrete samples were also collected from the locations corresponding to the highest white phosphorus concentrations previously found in Bread Truck Pond (sites 248 and 359) (Fig. III-2-3) and Racine Island (site 1246) (Fig. III-2-10) (Racine and Walsh 1994). All discrete samples were collected by scraping the top 5 cm of sediment into a sample jar.

We collected five sets of subsurface samples in Area C. Two samples points (883 and 972) are in the intermittent pond where we have monitored the loss of white phosphorus in the

surface sediments from 1992 to 1997 (M.E. Walsh et al. 1998). In 1998, we used a shovel to dig holes 30 cm deep, and we used a corer to take sediment samples from the wall of each hole at 0, 5, 10, 15, 20, 25, and 30 cm depth. We used this same sample collection method to obtain a subsurface samples within the DWRC Pen 5. Two cores were taken from Miller's Hole (Fig. III-2-2), the crater produced when a white phosphorus mortar round was detonated in May 1992. At this site, we used an Oakfield corer pushed to a depth of 20 cm. We divided each core in half, the top being surface sediment and the bottom subsurface sediment.

Laboratory analysis of sediments for white phosphorus residues

In the laboratory, each composite sample was thoroughly mixed by stirring and kneading. To obtain an estimate of average white phosphorus concentration, a 200-g subsample was taken from each composite and analyzed using solvent extraction (100 mL iso-octane) and gas chromatography (EPA SW-846 Method 7580). If concentrations were high, the remainder of each composite was rinsed through a 30-mesh sieve (0.59-mm sieve opening) to remove the fine grained sediment. Material remaining on the sieve was placed in a septa-jar and equilibrated at room tem-

perature. To determine if white phosphorus particles had been retained on the sieve, we performed headspace solid-phase microextraction (SPME) followed by gas chromatography (M.E. Walsh et al. 1995a). When the SPME method indicated that white phosphorus was present, the sample was spread in a thin layer on an aluminum pan and the sample was heated until all water evaporated. If white phosphorus particles were present, they are detected by the observation of a localized area of intense smoke and flame, and the formation of a bright orange residue.

Discrete samples were subsampled by taking a 40-g portion of each soil and extracting the white phosphorus with 20 mL of isooctane. Subsurface samples, which were obtained in the field with corers, were placed directly in isooctane. After shaking overnight, the extracts were analyzed by gas chromatography (EPA SW-846 Method 7580).

Sublimation-oxidation conditions

We installed sensors and dataloggers to monitor sediment temperature and moisture conditions using the same configuration of sensors as used in 1997 for most of the stations. At each station (Table III-2-1, Fig. III-2-11), sediment temperatures were monitored at 5- and 10-cm depths using Campbell Scientific (Logan, Utah) Model 107B soil/water thermistor probes. Sediment moisture conditions were monitored at 5- and 10-cm depths using Campbell Scientific Model 257 (Water-

mark 200) soil moisture sensors. Output from both sets of sensors was taken every 10 minutes, and the hourly and 24-hour averages recorded by a Campbell CR10 Measurement and Control Module and an SM716 Storage Module.

Tensiometers provided another measure of surface sediment moisture conditions. SoilMoisture[®] (SoilMoisture Equipment Corp., Santa Barbara, California) Series 2725 tensiometers equipped with dial gauges were installed, one at a 10-cm depth and another a 20-cm depth at most sites, and were read periodically by personnel from CH2M Hill. A third tensiometer was equipped with a pressure transducer and wired to the datalogger where 24-hour average measurements were computed and recorded on a storage module.

To monitor subsurface water level in Area C, we relocated a shallow piezometer well used in 1994 (site 3 in M.E. Walsh et al. 1995b), and placed the Druck pressure transducer 0.77 m below the sediment surface. We also installed Drucks to monitor the depth of any standing water in the ponds. However, the ponds were drained for most of the monitoring period, and exposure to the weather caused erratic readings for most of the sensors.

At each datalogger station in Area C, Pond 290, and Bread Truck Pond, we planted 10 white phosphorus particles (1.8 mm diameter, 5.6 mg) that were made in the laboratory (M.E. Walsh et al. 1995b). These particles were in

Table III-2-1. UTM coordinates and elevations of dataloggers used to record sublimation-oxidation conditions, 10 June to 27 August 1998.

<i>Datalogger site</i>	<i>E (m)</i>	<i>N (m)</i>	<i>Elevation (m)</i>
C 100m	355,024.49	6,801,302.48	4.68
BT N 100m	354,536.42	6,801,826.00	4.74
BT S 100m	354,521.08	6,801,724.34	4.76
Pond 293 (RI)	355,528.93	6,800,248.19	4.35
Pond 290 -1	354,448.16	6,800,327.11	4.66
Pond 290 -2	354,389.74	6,800,382.08	4.71
Pond 290 -3	354,320.27	6,800,421.78	4.67
A Pond - 1 (Pond 258)	353,995.90	6,800,703.71	4.61
A Pond - 2 (Pond 256)	353,829.47	6,800,780.97	4.53
C (piezo site from '94)	355,013.25	6,801,197.47	4.77

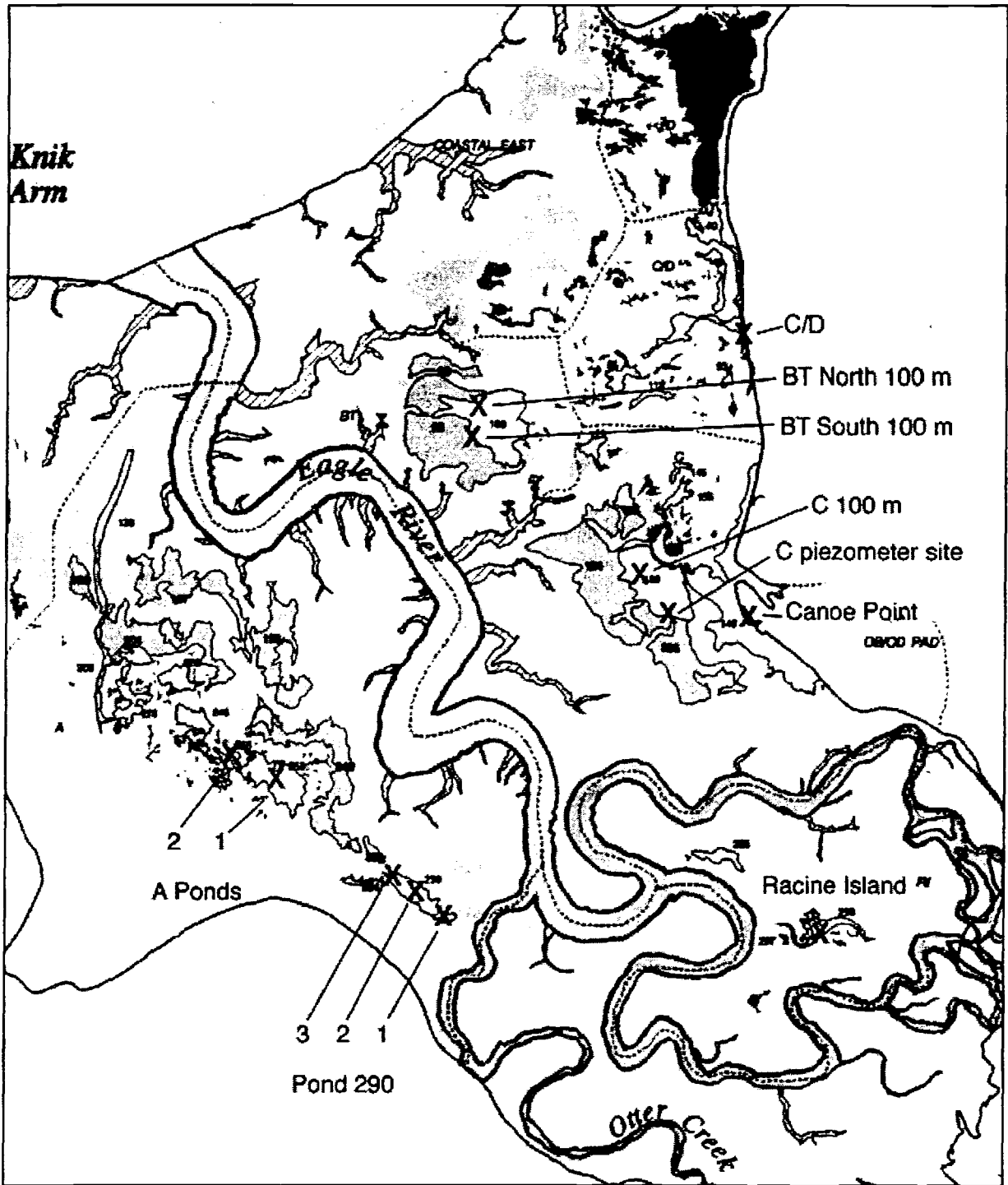

Figure III-2-11. Map of 1998 data logger locations.

addition to those we planted in Area C and Bread Truck Pond in 1997 and left over the winter. Each new particle was first inserted into a plug of saturated sediment, then the plug of sediment was placed in a nylon stocking, which was then placed within the top 5 cm of clean, saturated sediment at each monitoring station. We recovered five of the 1998 plugs from each station at the end of August to determine if white phosphorus mass had decreased. We also recovered those plugs left from 1997. To determine if the white phosphorus particles had changed, the sediment samples containing particles were placed into isooctane to extract white phosphorus residue prior to analysis by gas chromatography.

Surveying

Universal Transverse Mercator (UTM) horizontal coordinates and elevations were obtained using a Leitz SET4C electronic total station, as was done in previous years. For the Bread Truck Pond sample points and gully perimeter, a temporary benchmark was set up

on the north side of the Bread Truck. For Area A, a temporary benchmark was established near Pond 258. Area C locations were obtained from a benchmark on Canoe Point.

RESULTS AND DISCUSSION

Results of monitoring are discussed by location within ERF. White phosphorus concentrations for all samples are listed in Appendix III-2-A.

Area C

Sediment temperature and moisture conditions were monitored at two sites within Area C (Fig. III-2-2). Previous work has shown that to promote sublimation-oxidation of white phosphorus particles, sediments must first be desaturated. Then sublimation-oxidation will take place, and the rate at which it occurs increases exponentially with increased temperature. Moisture sensors at the C 100 m and C piezometer sites (Fig. III-2-12) showed

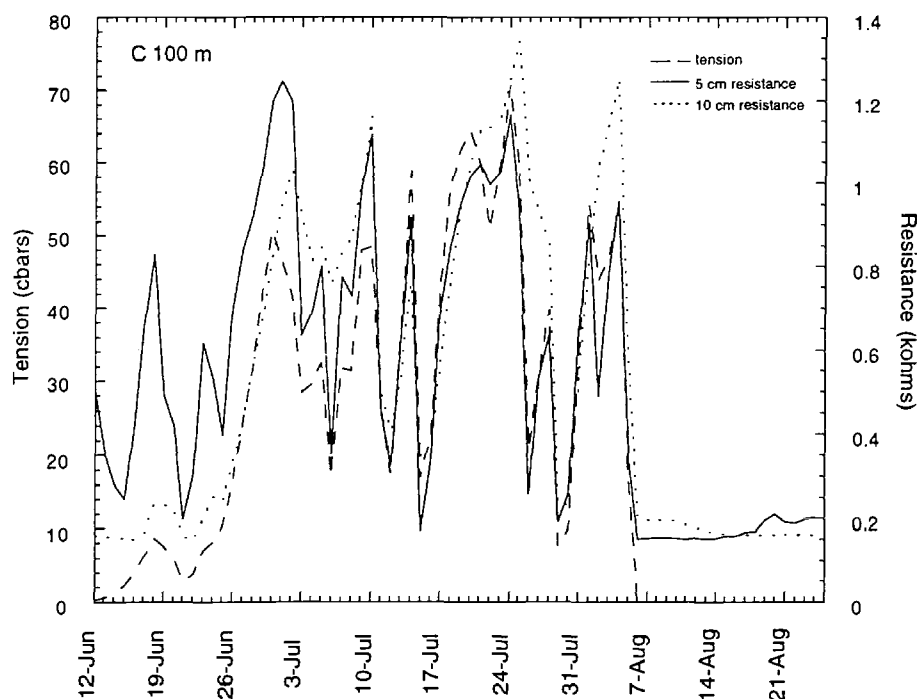

a.

Figure III-2-12. Output from moisture sensors during summer of 1998. Increases in resistance and tension indicate drying.

III-2. TREATMENT VERIFICATION

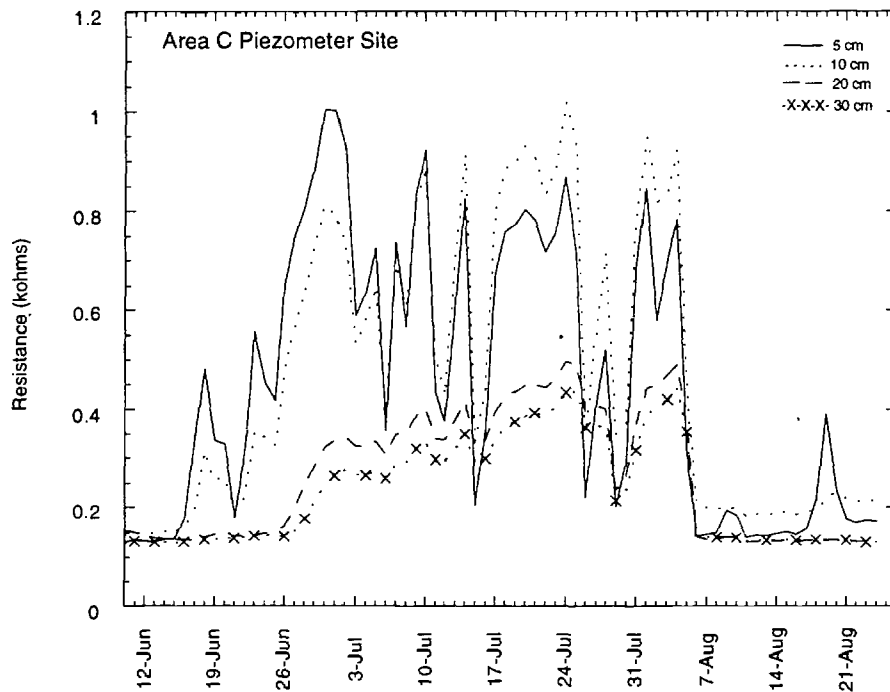

b.

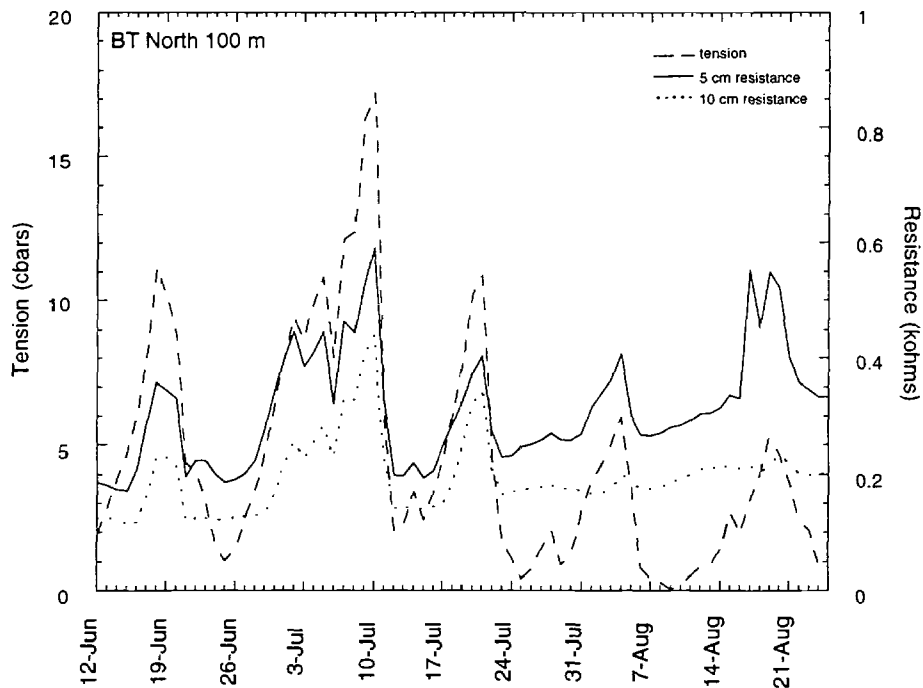

c.

Figure III-2-12 (cont'd).

EAGLE RIVER FLATS FY 98

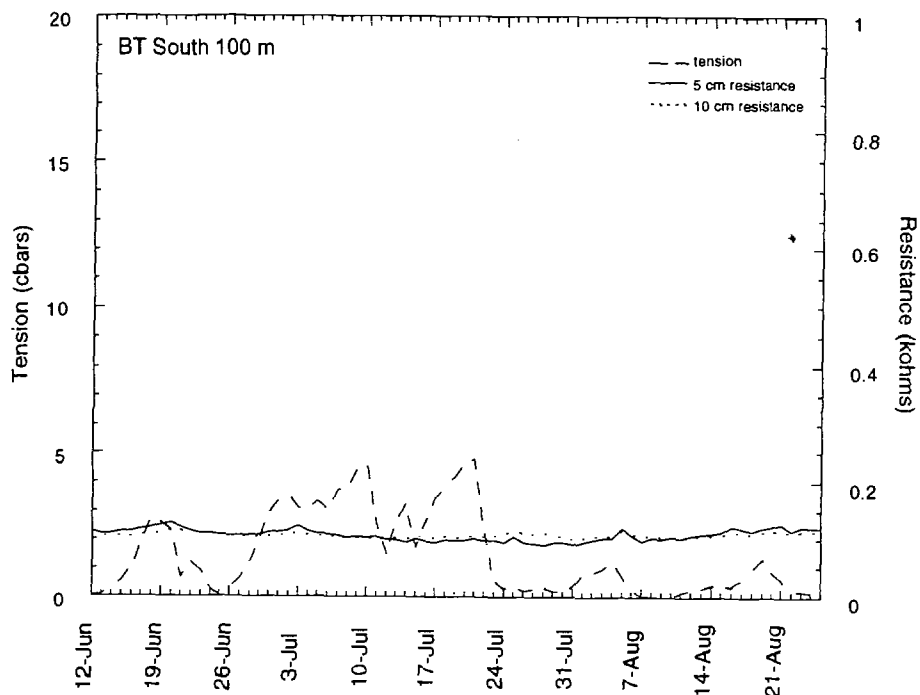

d.

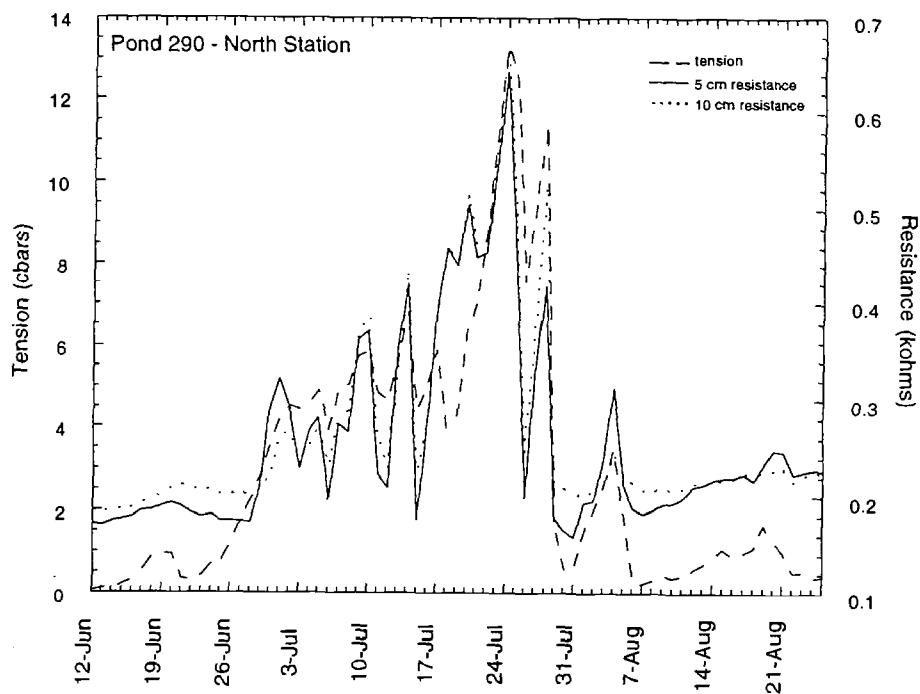

e.

Figure III-2-12 (cont'd). Output from moisture sensors during summer of 1998. Increases in resistance and tension indicate drying.

III-2. TREATMENT VERIFICATION

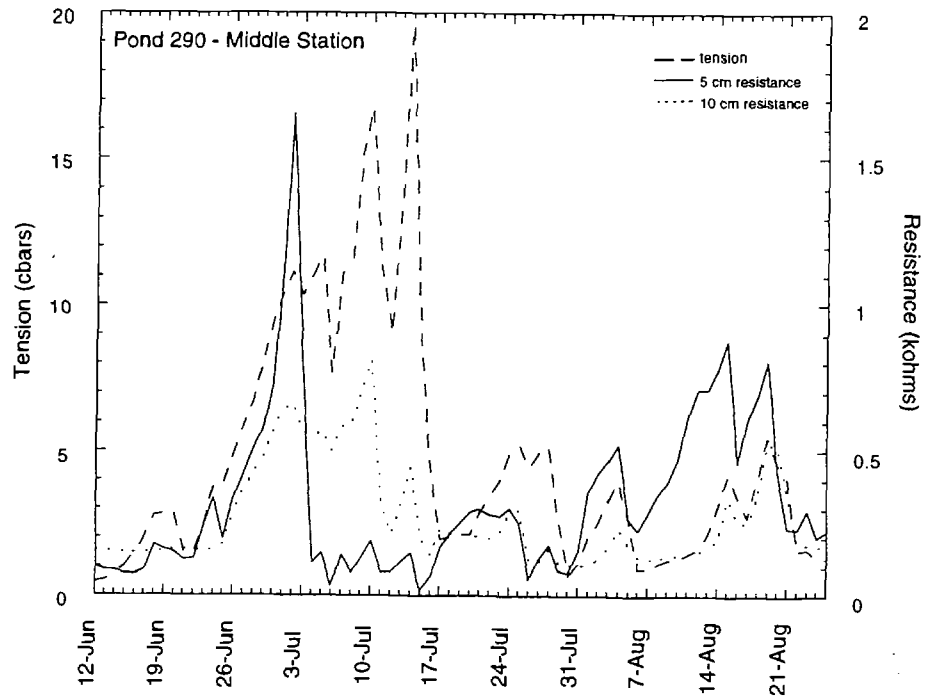

f.

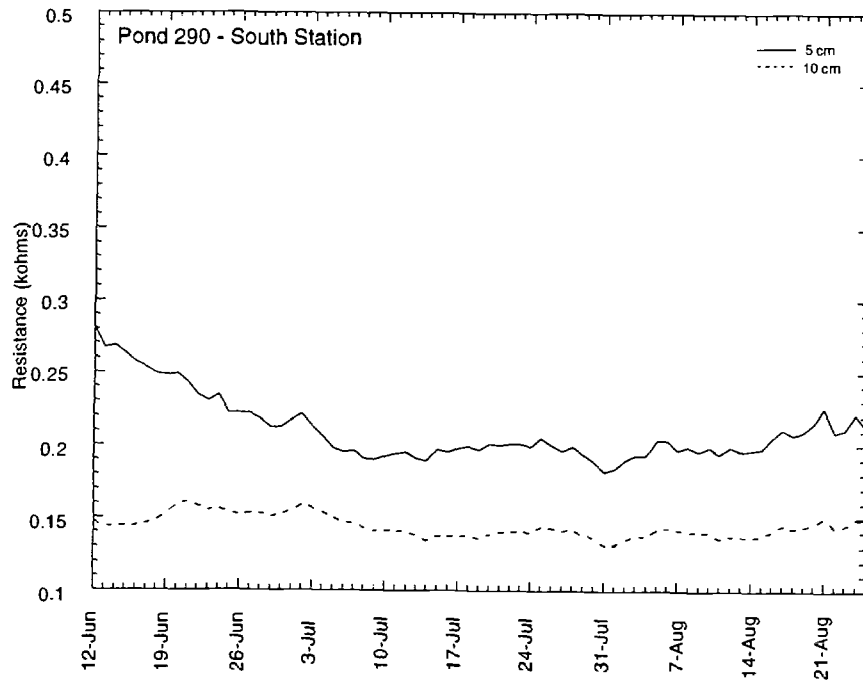

g.

Figure III-2-12 (cont'd).

EAGLE RIVER FLATS FY 98

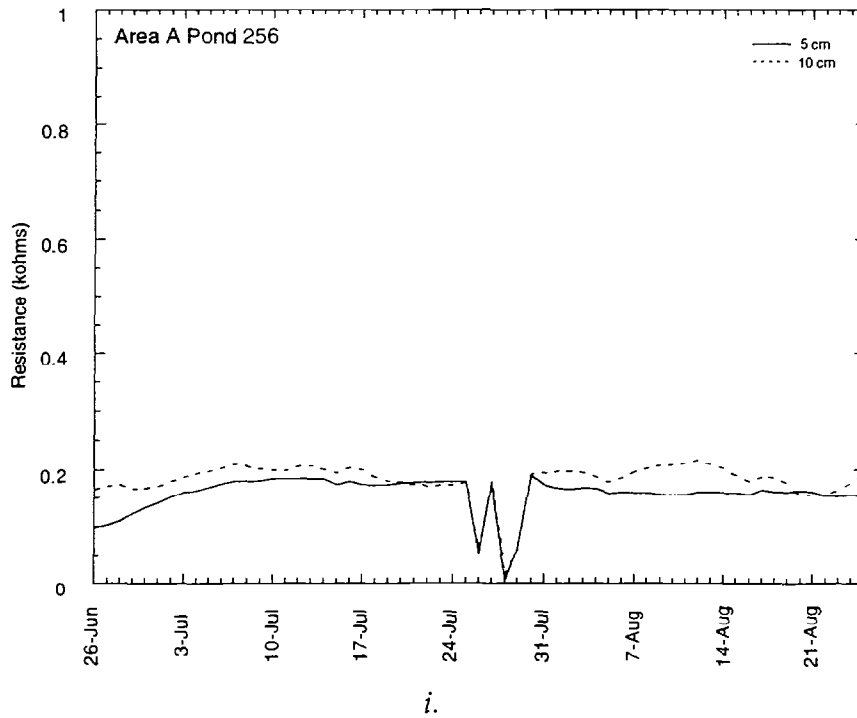
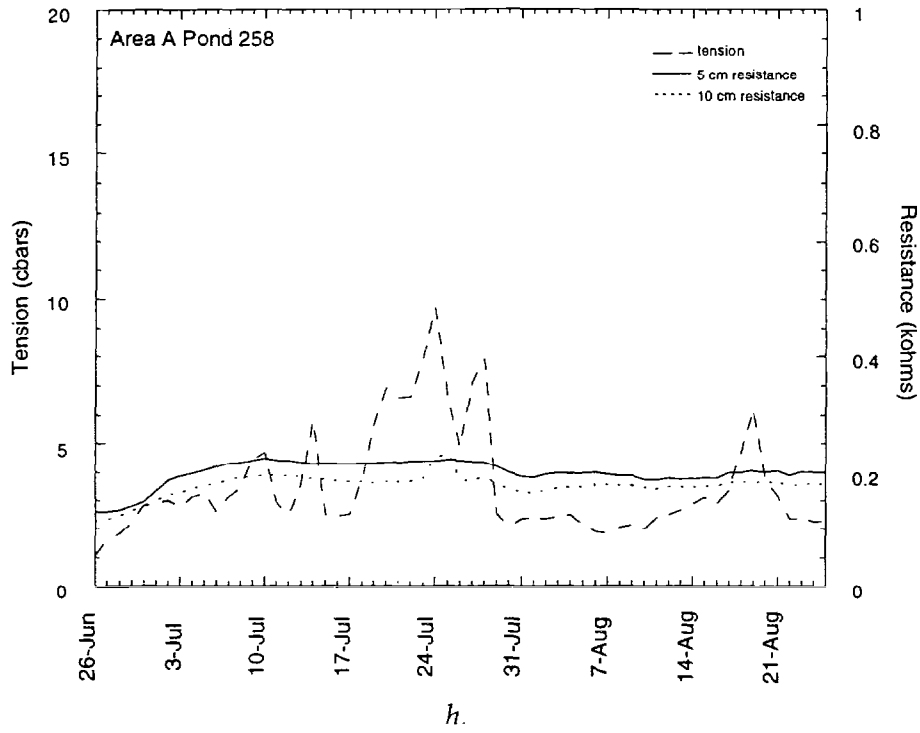

Figure III-2-12 (cont'd). Output from moisture sensors during summer of 1998. Increases in resistance and tension indicate drying.

that the sediments desaturated (increase in resistance and tension above baseline) around 17 June, and remained unsaturated until 5 August, when heavy rainfall followed by a flooding tide wetted the sediments; they remained wet for most of the rest of the summer. Sediment temperatures were considerably lower than last year at the C 100 m station. During the time that sediments were unsaturated, maximum 24-hour average temperatures at 5 cm depth were 21.72 and 18.34°C for 1997 and 1998, respectively. Mean temperatures at 5 cm depth were 17.53 and 15.79°C, for 1997 and 1998, respectively. Lack of sunshine probably accounted for the lower temperatures in 1998 (Collins, this volume).

The relationship between groundwater elevation and tension in the surface sediments is revealed in data from our piezometer data station. When groundwater elevations dropped to 50 cm below the sediment surface, tension rises above 5 cbars, the estimated air entry point for sediment in this part of ERF (M.E. Walsh et al. 1995b). The groundwater

elevation dropped below the bottom of the piezometer well (77 cm depth) on 26 June (Fig. III-2-13), and did not rise into the well again until 6 August, following heavy rainfall, then a flooding tide on 9 August. While the sediment was unsaturated, frequent rewetting by precipitation is shown by the wide fluctuations in tension.

In 1997, we collected composite samples from five grids in Area C, and found the highest concentrations in the sample (C 100 m) taken from the west side of Pond 183. In 1998 we collected replicate composite samples (five in June and five at the end of August) from this grid. This procedure differs in that last year we collected one composite sample and analyzed five 40-g subsamples of the homogenized composite. After consultation with Ramsey (1997), we collected five composite samples from the grid and analyzed one large (200-g) subsample of each homogenized composite. This procedure is supposed to give a better estimate of the mean concentration. Using this approach, we detected white phos-

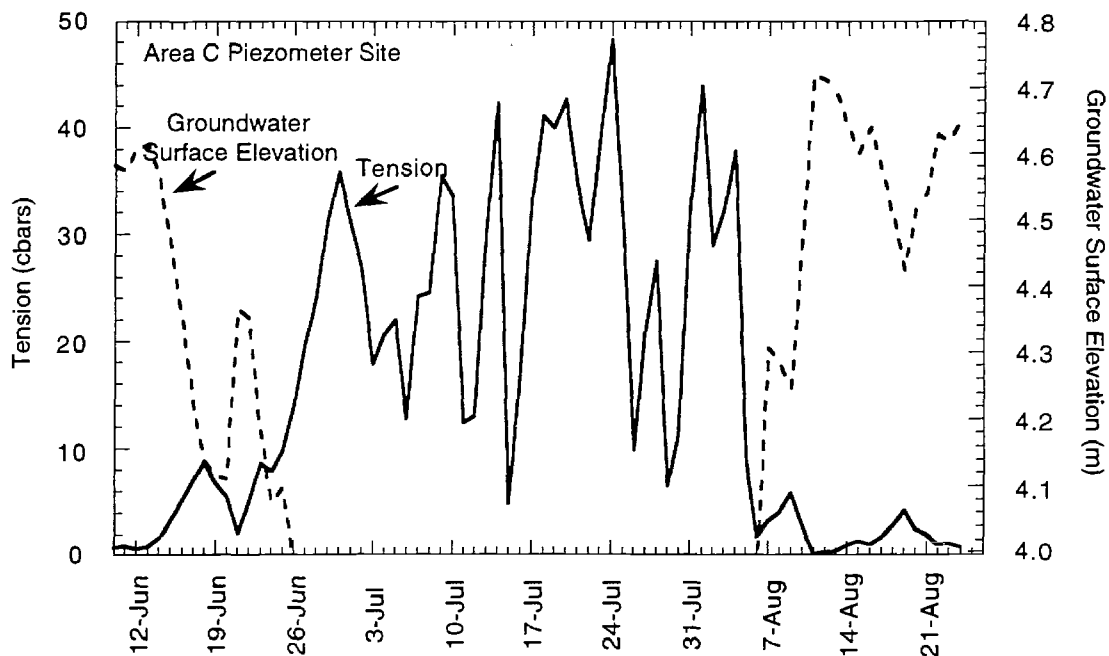

Figure III-2-13. Groundwater surface elevation in piezometer well located in Area C and the corresponding moisture content (tension) of the surface (elevation 4.77 m) sediment.

phorus in each sample we collected. In the June samples, the concentrations ranged from 0.0082 to 0.075 µg/g, with a median of 0.0188 µg/g. In the August sample, concentrations ranged from 0.0054 to 0.043 µg/g, with a median of 0.0074 µg/g. No white phosphorus particles were found in any of the composites.

We recovered the remains of white phosphorus

particles we planted in 1997 and 5 of the 10 we planted in 1998 (Table III-2-2). The amount of residue from particles we planted at the C 100 m datalogger station was strongly influenced by the cracking pattern of the surface sediment. A desiccation crack ran through the sediment where we planted the 1998 particles. For the five replicates, the range of white phosphorus found was 0.53 to 1.9 mg

Table III-2-2. Mass remaining from white phosphorus particles planted in the top 5 cm of sediment of drained ponds. The locations correspond to data stations established in 1997 and 1998.

Replicate	White phosphorus mass remaining (mg)†			
	'97-0 m	'97-100 m	'97-200 m	'98-100 m
Area C				
A	0.0002	1.2	0.6	0.5
B	0.4	1.6	0.7	1.1
C	5.0	4.3	1.3	1.1
D	5.1	5.2	3.1	1.3
E	5.4	5.3	4.8	1.9
mean	3.2	3.5	2.1	1.2
sum	16	18	11	5.9
% of sum remaining	57%	63%	38%	21%
BT South				
A	0.002	4.8	0.01	4.9
B	0.06	4.8	0.5	5.4
C	2.2	5.1	4.5	5.6
D	4.2	5.1	4.7	5.8
E	4.5	5.2	5.0	5.9
mean	2.2	5.0	3.0	5.5
sum	11	25	15	28
% of sum remaining	39%	90%	53%	99%
BT North				
A	0.488	0.006	0.000	0.2
B	2.5	0.001	0.001	0.2
C	5.0	0.9	0.005	0.4
D	5.2	5.1	4.6	0.4
E	5.6	5.3	4.6	6.1
mean	3.75	2.27	1.84	1.47
sum	19	11	9	7.3
% of sum remaining	67%	41%	33%	26%
Pond 290				
	'98-0 m	'98-80 m	'98-160 m	
A	3.7	1.1	1.4	
B	4.3	1.3	5.9	
C	5.3	1.3	6.0	
D	5.6	2.4	6.0	
E	5.6	5.0	6.2	
mean	4.9	2.2	5.1	
sum	25	11	26	
% of sum remaining	88%	40%	92%	

†Nominal initial mass is 5.6 ± 0.5 mg for each particle yielding an initial nominal sum of 28 mg for five replicates.

and the mean was 1.2 mg. Given the initial mass of 5.6 mg, the loss was 79%. Significant residues still remain from particles planted in 1997, which were not located within a desiccation crack. Heterogeneity of the surface sediment conditions is evident from the differences in mass remaining from the planted particles. However, the amount (sum of the masses for five replicates) remaining is less than what was planted, indicating that sublimation-oxidation is occurring.

In Area C, we also collected discrete samples where high concentrations of white phosphorus were found prior to draining. The first site was the location of the DWRC Pen 5, used in 1992 to 1993 for the evaluation of methyl anthranilate. We intensively sampled this pen in 1996, taking discrete samples at

the nodes of a 1.82-m square grid, 4 columns wide and 12 rows long (Fig. III-2-14). In 1996, all 48 samples contained detectable white phosphorus concentrations ranging from 0.0024 to 421 $\mu\text{g/g}$ (Table III-2-3). Over 300 white phosphorus particles were found, one of which weighed 150 mg (M.E. Walsh et al. 1997). In 1998, white phosphorus was undetectable in only 20 of the 48 samples. The concentration range in the positive samples was 0.00062 to 0.84 $\mu\text{g/g}$. In all cases where white phosphorus was found, the concentrations were lower in 1998 than in 1996 (Table III-2-3), and no white phosphorus particles were found.

The subsurface samples we collected also showed a decline in white phosphorus residues. The first two sampling points were in

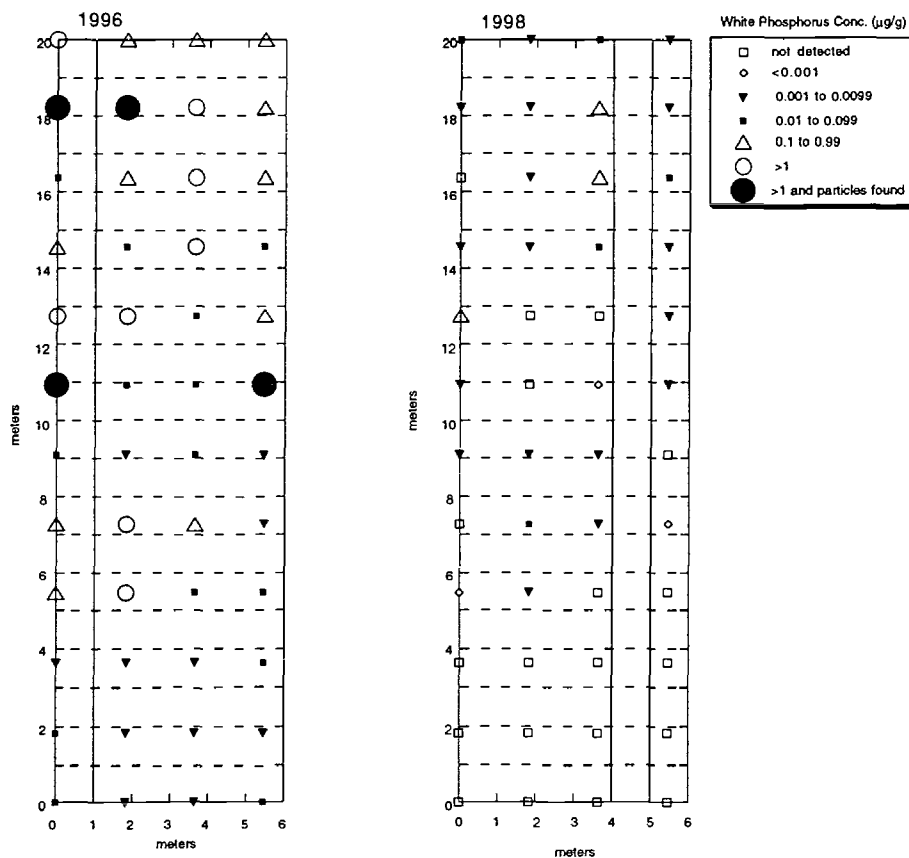

Figure III-2-14. Plot of white phosphorus concentrations found on a 1.82-m-square grid in 1996 and 1998 in DWRC Pen 5. Large black circles indicate discrete samples where white phosphorus particles were found. No particles were found in 1998.

Table III-2-3. White phosphorus concentrations found on a 1.82-m-square grid in 1996 and 1998 in DWRC Pen 5 (Fig. III-2-14).

Row/column	WP concentration ($\mu\text{g/g}$)	
	1996	1998
R1C1	0.049	not detected
R1C2	0.005	not detected
R1C3	0.003	not detected
R1C4	0.018	not detected
R2C1	0.022	not detected
R2C2	0.002	not detected
R2C3	0.003	not detected
R2C4	0.003	not detected
R3C1	0.008	not detected
R3C2	0.004	not detected
R3C3	0.008	not detected
R3C4	0.016	not detected
R4C1	0.102	0.0006
R4C2	4.30	0.0014
R4C3	0.032	not detected
R4C4	0.012	not detected
R5C1	0.135	not detected
R5C2	5.38	0.050
R5C3	0.551	0.0067
R5C4	0.010	0.0007
R6C1	0.029	0.0055
R6C2	0.009	0.0015
R6C3	0.076	0.0042
R6C4	0.008	not detected
R7C1	22.9	0.0048
R7C2	0.039	not detected
R7C3	0.058	0.0007
R7C4	25.3	0.0034
R8C1	8.52	0.21
R8C2	6.01	not detected
R8C3	0.015	not detected
R8C4	0.760	0.0037
R9C1	0.129	0.0033
R9C2	0.061	0.0010
R9C3	1.73	0.089
R9C4	0.063	0.0010
R10C1	0.034	not detected
R10C2	0.112	0.0021
R10C3	19.7	0.19
R10C4	0.279	0.053
R11C1	421	0.0029
R11C2	3.63	0.0024
R11C3	1.28	0.84
R11C4	0.69	0.0074
R12C1	5.24	0.026
R12C2	0.616	0.0042
R12C3	0.320	0.015
R12C4	0.337	0.0035

the intermittent pond of Area C at site 883 (Fig. III-2-2) and 2 m east at site 972. This location previously was severely contaminated with white phosphorus (Table III-2-4). In 1997, white phosphorus was undetectable in the surface sediment at site 883 and was 0.0006 $\mu\text{g/g}$ at site 972, significant declines from concentrations found previously—219 $\mu\text{g/g}$ (in 1992) for site 883 and 1794 $\mu\text{g/g}$ (in 1993) for site 972. Subsurface samples were not previously collected at these sites. Cores taken elsewhere in Area C in 1992 showed contamination down to 55 cm (Racine et al. 1993). The subsurface samples we collected this year at sites 883 and 972 showed little contamination (Table III-2-4) (one positive at 10 cm depth). Because firing of white phosphorus munitions was suspended in 1990, at least 8 years have passed since this intermittently flooded location was contaminated. It is now remediated.

The next set of subsurface samples we collected was from the permanent pond of Area C in the location of the DWRC pen 5 (Fig. III-2-2). The sediments at this location have been exposed for only parts of two summers as a result of the pumping treatability studies. The sampling grid established in 1996 showed the greatest contamination along the 11th row of the 12-row grid (Table III-2-3, Fig. III-2-14). The subsurface samples we collected this year were taken between columns 1 and 2, which previously had concentrations of 421 and 3.63 $\mu\text{g/g}$ in the surface sediment. The 1998 samples showed contamination down to 10 cm, with the highest concentration (0.33 $\mu\text{g/g}$) at 5 cm depth. Repeated sampling of this location in future years will tell us when remediation is finished.

We have sampled Miller's Hole, the crater produced in 1992 from the detonation of a white phosphorus UXO, and found a significant decrease in concentrations with time in the surface sediments (Table III-2-5). In 1997 we collected two narrow cores down to 20 cm from the center of the crater and found high concentrations (up to 1730 $\mu\text{g/g}$) in the deepest (20 cm) part of the core. Subsurface sampling using coring is less accurate than the method we used elsewhere owing to compression of the core. However, Miller's Hole

Table III-2-4. White phosphorus found at depth in samplest collected on 21 August 1998 in the drained pond of Area C at sites 883, 972, and Pen 5.

	White phosphorus concentration (µg/g)††		
	Site 883	Site 972	Pen 5 Row 11
Surface	not detected	not detected	0.121
5 cm	not detected	not detected	0.330
10 cm	not detected	0.0019	0.011
15 cm	not detected	not detected	not detected
20 cm	not detected	not detected	not detected
25 cm	not detected	not detected	not detected
30 cm	not detected	not detected	not collected

†Shovel used to dig hole. Syringe corer (20 cm³) used to obtain core from wall of hole.
 ††Maximum concentrations previously found were 219 µg/g (in 1992), 1794 µg/g (in 1993) and 421 µg/g (in 1996) for sites 883, 972, and Pen 5 Row 11.

is small and we want to preserve it for monitoring in the future. Using the same coring method as in 1997, we obtained two narrow cores down to 20 cm. The actual core lengths were only 12 cm because of compression of the sediment. The 1998 concentrations were 0.037 and 0.0009 µg/g in the top halves and 0.25 and 0.10 µg/g in the bottom halves (much less than in 1997).

In consideration of all of the above, the main pond of Area C, once the cause of numerous waterfowl poisonings, is slowly losing its deadly contaminant.

Bread Truck Pond

The former Bread Truck Pond (Pond 109) is no longer a permanent pond because of the drainage ditch excavated in April 1996, connecting an existing tidal gully with the pond (Collins et al. 1997). Since its excavation, the ditch has continued to enlarge each year, as headward erosion extends the ditch southward into the former pond area (Fig. III-2-15 and III-2-16). The head of the ditch has bifurcated into two main lobes leading toward the southwest and the southeast. During 1998 the head of the southwest lobe has moved an additional 10 m into the pond. The small drainage channels leading to the head of the gully that are visible in the photo have intercepted a low swale within the pond basin that, in past years, would have held water once the high tide had receded (as shown in the 1996 photo in Fig. III-2-3). Now, the water drains quickly

Table III-2-5. White phosphorus concentrations found at Miller’s Hole, a crater produced by the detonation of a WP UXO.

Sampled	Days since explosion	WWP concentration (µg/g)	
		Center	Rim
5/20/92	0	2,394	979
8/21/92†	93	184	0.00427
8/27/93†	464	81.5	0.00177
8/30/94	832	9.5	not detected
9/17/95††	1215	166	0.0006
9/3/97	1932	1.6	not detected
8/25/98	2288	0.037	not detected

†Crater under water when sampled.
 ††Crater under water all summer.

from the swale through the small channels, leaving little or no standing water within the swale. However, the uneven topography of the south side of the pond still hampers efficient draining.

Erosion along the end and edges of the ditch occurs during the ebb tide events. As water flows out of the pond basin back into the ditch, it undercuts the bank, causing blocks of sediment to slump off. This process is most active at the heads of the lobes where deep plunge pools have formed. The process also affects the sides of the ditch to a much lesser degree. The average width of the ditch has not changed much from the 10 m observed in Sept 1996. Several localized slump areas have widened the ditch in a few spots.

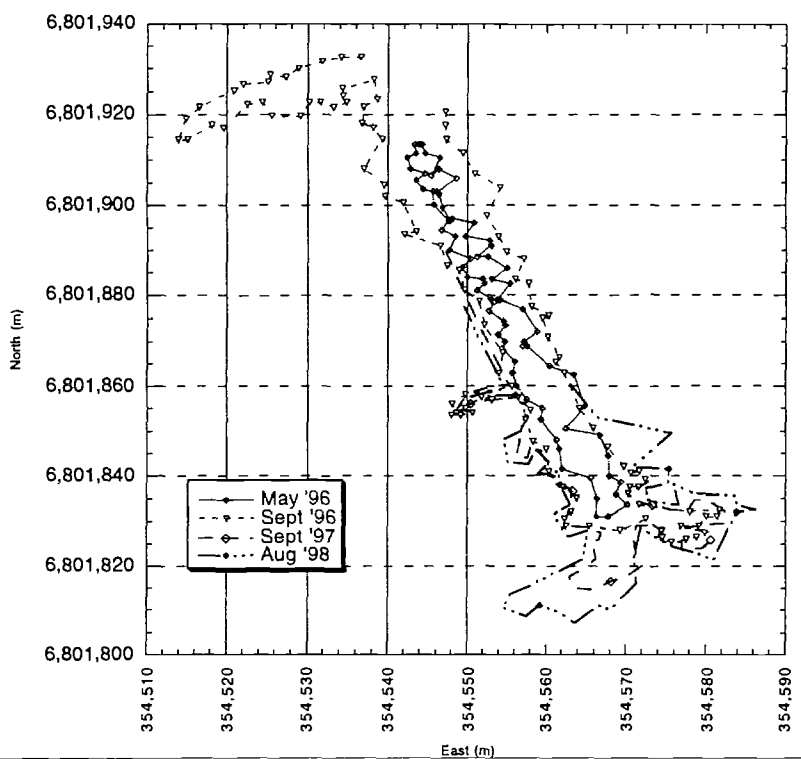

Figure III-2-15. Map showing advancement of the Bread Truck drainage ditch bank between May 1996 and August 1998.



Figure III-2-16. Aerial view of the northern edge of the Break Truck Pond showing the drainage ditch extending into the pond and erosion of the surface sediment.

The largest of these is along the east side of the ditch, about 40 m from the head. Here, a large slump has widened the ditch to nearly 20 m.

The ebb flow of water back into the ditch after each flooding tide is also eroding the top sediment layer from a broad area of the pond bottom surface on either side of the ditch. Up to 10 cm or more of sediment has been stripped off by the ebb tides. The sediment is often eroded down to a buried organic layer that is more resistant to erosion. This now exposed organic layer can be seen in Figure III-2-16 as a darker area on either side of the ditch. This stripped off area extends west of the ditch all of the way to the datalogger at BT North 100, seen as the white box on the tripod. This buried organic layer is a former vegetated surface representing a sedge meadow community present before the formation of the permanent pond. Early aerial photographs of Eagle River Flats indicate that much of the Bread Truck Pond formed after the 1964 earthquake, most likely caused by the up to 0.6-m settlement of the area that was triggered by the earthquake.

Because of erratic output from the exposed Druck pressure transducers installed at the BT North 100 and BT South 100 dataloggers, we were not able to record water depths at either site. Thus, we do not know exactly how often the sites were flooded by tides this summer. The plot of soil moisture sensors for BT North 100 (Fig. III-2-12) shows five reductions in the tensiometer readings that correspond to tidal events where flooding tides over about 9 m (29.6 ft) (Anchorage Tidal Datum) took place. The tidal periods and number of high tides over 9 m (29.6 ft) are summarized in Table III-2-6. Based on the number of flooding tides, approximately 39 ebb tides contributed to erosion at the head of the ditch and the stripping of sediment from the pond bottom surface.

Because of frequent precipitation and poor drainage, sublimation-oxidation conditions were unfavorable at the BT South 100 m data station (Fig. III-2-3); the moisture sensors showed that the sediments were saturated all summer (Fig. III-2-12). In contrast, the sedi-

ments at the BT North 100 m station did desaturate periodically. This station is quite close to the ditch, and when the tide is low, the large head difference between the base of the ditch and the station would readily drain and desaturate the sediments.

<i>Period with flooding tides</i>	<i>Number of flooding tides</i>
20-27 June	12
10-12 July	3
22-26 July	5
7-14 August	12
21-25 August	7

ments at the BT North 100 m station did desaturate periodically. This station is quite close to the ditch, and when the tide is low, the large head difference between the base of the ditch and the station would readily drain and desaturate the sediments.

Because of variation among replicates, the composite samples collected from both sites within the Bread Truck Pond do not show a significant change in white phosphorus concentrations.

Poor sublimation-oxidation conditions at the BT South 100 m station were confirmed by the residue remaining from planted particles. For the five replicates planted in 1998, the range of white phosphorus found was 4.88 to 5.93 mg and the mean was 5.53 mg (insignificant from the initial mass of 5.6 mg). In contrast, four of the five replicate particles planted at BT North 100 m station decreased to less than 1 mg (Table III-2-2), and one particle was unchanged.

We collected discrete samples from two sites within the Bread Truck Pond (Fig. III-2-3), designated sites 248 and 359, that, when sampled in 1991, had white phosphorus concentrations of 58 and 34 $\mu\text{g/g}$, respectively (Racine and Walsh 1993). Both of these sites are located just west (<40 m) from the composite grid at BT North 100 m. Both sites were within the permanent pond prior to blasting of the ditch in April 1996, and have been exposed for three summers. No white phosphorus was detected in either sample, indicating that drying of the sediment is removing white phosphorus.

Pond 155 (Northern C)

Of the two composites collected from this small pond, the grid to the northeast was blank and the grid to the southwest had a white phosphorus concentration of $0.023 \mu\text{g/g}$. Two discrete samples were collected in 1992 from within the southwest grid, both of which were positive (0.0028 and $0.132 \mu\text{g/g}$). We did not install a datalogger at this site to monitor moisture conditions, so we do not know if the sediments of this pond dried after pumping. We sieved the 1998 positive sample through a 0.5-mm sieve, but found no white phosphorus particles.

Pond 290 (Area A)

None of the composite samples we collected from Pond 290 had detectable white phosphorus.

This pond was drained by pumping as part of a feasibility study for pumping a pond in a remote location. Sublimation-oxidation conditions were intermittently favorable for much of the middle of the pond. Large desiccation cracks formed over much of the pond surface, and the data station we located in the middle of the pond (290-80 m) had cracks large enough to expose some of our moisture sensors. Four of the five particles we planted at this station decreased in size significantly (Table III-2-2). The mean for five replicates was 2.2 mg (60% average loss). The frequent rainfall and resulting surface runoff and possible groundwater recharge resulted in less drying at the north and south extremes of the pond. Only one particle planted at the north station (290-160 m) declined, and loss was insignificant at the south station (290-0 m).

Ponds 258 and 256 (Northern A)

Composite sampling in Ponds 258 and 256 confirmed previous results obtained by discrete sampling. White phosphorus is present, but sporadically, and when found, the concentrations are low. Only three of the 44 composite samples contained detectable white phosphorus. These composite samples and previous discrete samples show that white phosphorus munitions were fired near Pond 258, probably in the heavily cratered mudflat

to the north and east. However, we have not found hotspots in this pond similar to those in Area C, Bread Truck Pond, and Racine Island.

Ponds 293 and 297 (Racine Island)

In contrast to samples collected in Area A, all the samples collected from Racine Island were positive. The composite sample from Pond 297 had a white phosphorus concentration over $200 \mu\text{g/g}$. Approximately 400 mL of this composite sample was sieved, and seven gravel size pieces of white phosphorus were found. This small pond was mapped as 0.028 ha (0.6 acre). Given its small size, severe contamination, low elevation, and frequent flooding, covering should be considered to prevent waterfowl from feeding in these sediments.

Assessment of monitoring methods

White phosphorus remains a difficult contaminant to characterize. We know that when conditions are favorable, white phosphorus particles will vaporize (sublime). The rate at which the particles vaporize is influenced by several factors.

- *Size of particles:* Because loss to vaporization is from the surface of each particle, large particles take longer to vaporize than small particles. For example, a single 10-mg particle of white phosphorus would take as much as five times longer to vaporize than ten 1-mg particles because surface-area-to-volume ratio is greater for small particles.
- *Exposure to atmosphere:* To vaporize, the particle must be exposed to the atmosphere. For particles buried in sediment, the pore structure and moisture content of the sediment control the exchange of gases between the atmosphere and the subsurface particles. If the sediment is saturated with water, gas exchange is diminished. As the sediments dry, large pores will drain first, allowing gas exchange. One of the first differences noticeable at ERF when the ponds are drained and the sediments exposed is the change in color of the exposed surface sediment from black to gray. As we sampled, we

noticed that the subsurface sediment was mottled in color, with veins of gray and black. Black is indicative of anoxic sediment, and gray is indicative of air entry into the sediment, which occurs first in large pores within the sediment (Hemond and Chen 1990). Because of greater air exchange through large pores, white phosphorus particles located within the large sediment pores will vaporize faster than those embedded by sediment with small pores. Another prominent feature of the surface sediment in drained ponds in ERF is the desiccation cracking that occurs as the sediments dry. White phosphorus particles located in or near these cracks will also vaporize faster than those bur-

ied in uncracked sediment, again because of greater air exchange.

- *Temperature*: Once particles are exposed to the atmosphere, the vaporization rate increases exponentially with temperature. The range of temperature fluctuations in the surface sediment (Fig. III-2-17) varies significantly with depth; thus, slight differences in the depth of white phosphorus particles could strongly influence persistence.

Variation in each of the above factors, in addition to uncertainty associated with the distribution of white phosphorus from training (i.e., we have no idea where and how many white phosphorus rounds were fired into ERF over the last half century), require

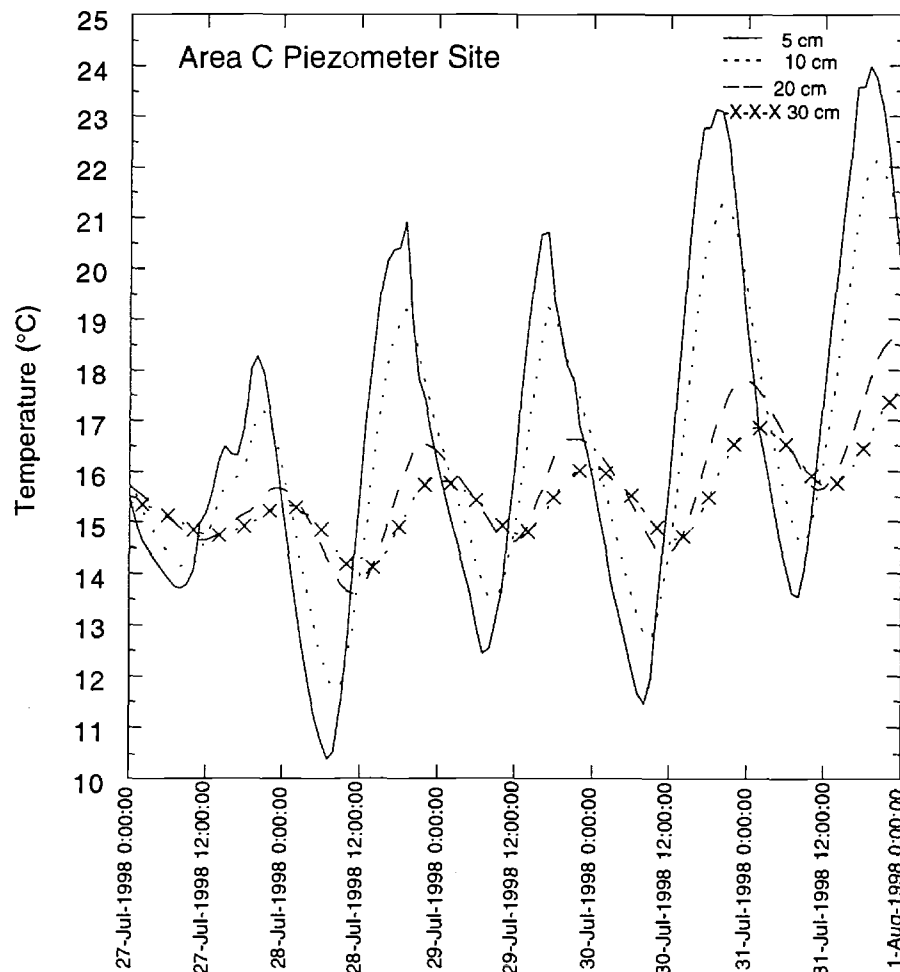

Figure III-2-17. Output from temperature sensors in Area C showing magnitude of sediment temperature fluctuations with depth.

that we use multiple methods to monitor the effectiveness of pond draining. We have used the methods described in this report for 2 years to assess the persistence of white phosphorus in the surface sediments of drained ponds. Based on this experience, we have found that each method has strengths and weaknesses, depending on the objective.

Data stations

The objective of the data stations is to monitor sediment moisture and temperature conditions to confirm that draining by pumping or ditching is inducing conditions that will result in decontamination of ERF sediment. For the most part, these data stations have been quite reliable, and, because they record data on an hourly basis, we have a record of the conditions throughout the summer (rather than "snap shot" or point in time data). Placement of the data stations along transects bisecting a pond, as was done in 1997 in Area C, Bread Truck Pond, and in 1998 in Pond 290 (Area A) provides information on the variation of conditions within a drained pond.

Planted particles

Measurement of the persistence of the particles we have planted in ERF sediment provides a rigorous test of sublimation-oxidation conditions because these particles are larger than most of the particles we have isolated from ERF sediment and are therefore more persistent. Multiple years are required for complete vaporization. Large differences in masses remaining for closely spaced particles reveal the heterogeneity of conditions within the sediment. None of the particles we have planted in ERF have shrunk to an undetectable mass, as occurred within 2 years with particles planted in the Retention Basin, which is not susceptible to flooding tides.

Composite sampling

The objectives of composite sampling are to provide a measure of average concentration over a large area and to detect the presence of hot spots containing white phosphorus particles large enough to present a lethal dose to a duck. All of the composite sampling

we have conducted so far had been in areas previously sampled by collecting discrete samples along transects. The results of the composite sampling have confirmed the results of previous discrete sampling as to the severity of contamination within ponds. For example, previous discrete sampling showed that contamination within the Bread Truck pond was greatest along a line extending south of the Bread Truck target. Composite sampling showed the same results. In terms of showing concentration trends with time, composite sampling is useful for confirming changes from high to low concentrations. It is less valuable for showing changes once the concentrations are below those associated with the presence of white phosphorus particles. Previously, we have found that low concentrations can persist for many years. At low concentrations the white phosphorus is most likely sorbed within the matrix of the sediment, where it is quite stable but unlikely to present a hazard to waterfowl.

Discrete sampling

We have supplemented the results of composite sampling with repeated discrete sampling at formerly highly contaminated sites. This resampling has been useful for showing changes in concentration with time for white phosphorus derived from training with munitions prior to the cessation of firing. When white phosphorus becomes undetectable at these locations, we have convincing evidence that the treated pond will not be a hazard to feeding waterfowl.

CONCLUSIONS

Despite frequent precipitation and lack of solar radiation during the summer of 1998, pumping in Area C and Pond 290 of Area A resulted in desaturation of the sediments for part of the summer. Sampling of Pond 183 of Area C, which historically was the cause of significant waterfowl mortality, showed that the white phosphorus contamination is decreasing. Based on the loss of white phosphorus from the neighboring intermittent pond

(164), the surface sediments can be completely decontaminated within 7 years if the sediments are desaturated for at least part of the summer.

Composite sampling in Area A confirmed results of prior discrete sampling. Samples from Pond 290 were free of white phosphorus contamination; 3 out of 44 samples collected from Pond 258 were positive; concentrations were low. Area A continues to be an enigma; if a hotspot of contamination exists within the permanent ponds, we have yet to locate it.

The north side of Bread Truck Pond is intermittently desaturating because of the drainage ditch, which continues to advance into the former ponded area. White phosphorus contamination is declining as a result of this drying.

Racine Island remains severely contaminated. Although the drainage ditch removed much of the open water habitat, the sediments remain saturated owing to low elevation and frequent flooding. Waterfowl feeding in Pond 297 are at severe risk; further action, such as covering with gravel, should be considered.

Waterfowl continue to be poisoned by white phosphorus at Eagle River Flats. Because the Bread Truck Pond and much of Area C were without standing water in August 1998, when first phase of the mortality monitoring was conducted by DWRC, the source of the poison must be elsewhere. Racine Island Ponds 293 and 297 may account for some of the poisonings because of the large reservoir of white phosphorus in the surface sediments, but the waterfowl use of these ponds is low. While there is little open water habitat, the future of birds that feed there is bleak. The EOD pond (Pond 146) was partially dredged (1995–96) and pumped (1998), but still may contain white phosphorus in the undredged areas. Deepening of the sump hole in 1999 should result in removal of standing water and some drying of the surface sediment. The west side of Area C/D has not been sampled, but its proximity to the Bread Truck Pond make it a likely candidate for contamination. Aerial photographs indicate that the open water habitat has enlarged in parts

of C/D and remapping of the ponds is needed, as well as sampling for white phosphorus. Lastly, Area A, which is a large area with numerous small ponds, is heavily used by waterfowl. Composite sampling may help to locate white phosphorus hot spots, if they exist, in ponds not previously sampled.

REFERENCES

- Collins, C.M., M.T. Meeks, M.R. Walsh, M.E. Walsh and R.N. Bailey** (1997) Pond draining treatability: 1996 studies—the draining of Bread Truck Pond. In Interagency expanded site investigation: Evaluation of white phosphorus contamination and potential treatability at Eagle River Flats, Alaska (C.M. Collins and D. Cate, Eds.). CRREL Contract Report to U.S. Army, Alaska, Directorate of Public Works. FY96 Final Report, p. 51–71.
- Hemond, H.F. and D.G. Chen** (1990) Air entry in salt marsh sediments. *Soil Science*, 150(1): 459–468.
- Racine, C.H., M.E. Walsh, C.M. Collins, D. Lawson, K. Henry, L. Reitsma, B. Steele, R. Harris and S.T. Bird** (1993) White phosphorus contamination of salt marsh sediments at Eagle River Flats, Alaska. Part II. Remedial investigation report. CRREL Contract Report to the U.S. Army Environmental Center, Aberdeen Proving Ground, MD. AEC Report No. ENAEC-IR-CR-93063.
- Racine, C.H. and M.E. Walsh** (1994) WP in sediment. In Interagency expanded site investigation: Evaluation of white phosphorus contamination and potential treatability at Eagle River Flats, Alaska (C.H. Racine and D. Cate, Eds.). CRREL Contract Report to U.S. Army Garrison, Alaska, Directorate of Public Works. FY93 Final Report, p. 153–184.
- Ramsey, C.** (1997) Sampling for environmental activities. In *13th Annual Waste Testing and Quality Assurance Symposium, July 1997, Washington, DC*.
- U.S. Environmental Protection Agency** (1995) Method 7580: White phosphorus (P₄) by solvent extraction and gas chromatography. In *Test methods for evaluating solid*

waste, physical/chemical methods (SW-846), Update III. Washington D.C.: U.S. EPA, Office of Solid Waste, p. 7580-1 to 7580-20.

Walsh, M.E., C.R. Racine, C.M. Collins, C. Bouwkamp and P.G. Thorne (1995a) Simple field screening method for white phosphorus (P_4) in sediment. USA Cold Regions Research and Engineering Laboratory, Special Report 95-25.

Walsh, M.E., C.M. Collins and C.R. Racine (1995b) Factors that determine the persistence of white phosphorus particles in sediment. USA Cold Regions Research and Engineering Laboratory, CRREL Report 95-23.

Walsh, M.E., C.M. Collins and R.N. Bailey (1997) Demonstration of sample compositing methods to detect white phosphorus particles. In Interagency expanded site investigation:

Evaluation of white phosphorus contamination and potential treatability at Eagle River Flats, Alaska (C.M. Collins and D. Cate, Eds.). CRREL Contract Report to U.S. Army, Alaska, Directorate of Public Works. FY96 Final Report, p. 35-50.

Walsh, M.E., C.M. Collins and R.N. Bailey (1998) Treatment verification: Monitoring the remediation of white-phosphorus-contaminated sediments of drained ponds. In Interagency expanded site investigation: Evaluation of white phosphorus contamination and potential treatability at Eagle River Flats, Alaska (C.M. Collins and D. Cate, Eds.). CRREL Contract Report to U.S. Army, Alaska, Directorate of Public Works. FY97 Final Report, p. 41-62.

**APPENDIX III-2-A: WHITE PHOSPHORUS CONCENTRATIONS
FOR ALL SAMPLES**

Grid composite samples

	Type of composite	WP conc. ($\mu\text{g/g}$)	Number subsamples in composite	Nominal volume of subsamples (mL)	Type of subsample	Date composite collected	Collector	Mass of composite (g)	Analysis method	Date analyzed
Area A Composites 1998										
Pond 258 South 0 m minus	1.82 m square grid with 4 columns	<d	24	31	Discrete Core (Oakfield)	20-Aug-98	ME Walsh and RN Bailey	921	Solvent Extraction and GC	10-Sep-98
Pond 258 South 0 m plus	1.82 m square grid with 4 columns	<d	28	31	Discrete Core (Oakfield)	20-Aug-98	ME Walsh and RN Bailey	1261	Solvent Extraction and GC	10-Sep-98
Pond 258 South 20 m minus	1.82 m square grid with 4 columns	<d	36	31	Discrete Core (Oakfield)	20-Aug-98	ME Walsh and RN Bailey	1431	Solvent Extraction and GC	10-Sep-98
Pond 258 South 20 m plus	1.82 m square grid with 4 columns	<d	48	31	Discrete Core (Oakfield)	20-Aug-98	ME Walsh and RN Bailey	2056	Solvent Extraction and GC	10-Sep-98
Pond 258 South 45 m minus	1.82 m square grid with 4 columns	0.0013	48	31	Discrete Core (Oakfield)	20-Aug-98	ME Walsh and RN Bailey	1565	Solvent Extraction and GC	10-Sep-98
Pond 258 South 45 m plus	1.82 m square grid with 4 columns	<d	44	31	Discrete Core (Oakfield)	20-Aug-98	ME Walsh and RN Bailey	1825	Solvent Extraction and GC	10-Sep-98
Pond 258 South 70 m minus	1.82 m square grid with 4 columns	<d	32	31	Discrete Core (Oakfield)	20-Aug-98	ME Walsh and RN Bailey	1264	Solvent Extraction and GC	10-Sep-98
Pond 258 South 70 m plus	1.82 m square grid with 4 columns	<d	24	31	Discrete Core (Oakfield)	20-Aug-98	ME Walsh and RN Bailey	846	Solvent Extraction and GC	10-Sep-98
Pond 258 South 90 m minus	1.82 m square grid with 4 columns	<d	32	31	Discrete Core (Oakfield)	20-Aug-98	ME Walsh and RN Bailey	1031	Solvent Extraction and GC	10-Sep-98
Pond 258 South 90 m plus	1.82 m square grid with 4 columns	<d	48	31	Discrete Core (Oakfield)	20-Aug-98	ME Walsh and RN Bailey	1565	Solvent Extraction and GC	10-Sep-98
Pond 258 Center 0 m minus	1.82 m square grid with 4 columns	<d	36	31	Discrete Core (Oakfield)	20-Aug-98	ME Walsh and RN Bailey	1854	Solvent Extraction and GC	9-Sep-98
Pond 258 Center 0 m plus	1.82 m square grid with 4 columns	<d	44	31	Discrete Core (Oakfield)	20-Aug-98	ME Walsh and RN Bailey	1508	Solvent Extraction and GC	9-Sep-98
Pond 258 Center 20 m minus	1.82 m square grid with 4 columns	<d	40	31	Discrete Core (Oakfield)	20-Aug-98	ME Walsh and RN Bailey	1675	Solvent Extraction and GC	9-Sep-98
Pond 258 Center 20 m plus	1.82 m square grid with 4 columns	<d	48	31	Discrete Core (Oakfield)	20-Aug-98	ME Walsh and RN Bailey	2026	Solvent Extraction and GC	9-Sep-98
Pond 258 Center 40 m minus	1.82 m square grid with 4 columns	<d	40	31	Discrete Core (Oakfield)	19-Aug-98	ME Walsh and RN Bailey	1326	Solvent Extraction and GC	9-Sep-98

Grid composite samples

	Type of composite	WP conc. (µg/g)	Number subsamples in composite	Nominal volume of subsamples (mL)	Type of subsample	Date composite collected	Collector	Mass of composite (g)	Analysis method	Date analyzed
Pond 258 Center 40 m plus	1.82 m square grid with 4 columns	<d	44	31	Discrete Core (Oakfield)	19-Aug-98	ME Walsh and RN Bailey	1475	Solvent Extraction and GC	9-Sep-98
Pond 258 Center 60 m minus	1.82 m square grid with 4 columns	<d	36	31	Discrete Core (Oakfield)	19-Aug-98	ME Walsh and RN Bailey	1461	Solvent Extraction and GC	9-Sep-98
Pond 258 Center 60 m plus	1.82 m square grid with 4 columns	<d	48	31	Discrete Core (Oakfield)	19-Aug-98	ME Walsh and RN Bailey	1723	Solvent Extraction and GC	9-Sep-98
Pond 258 Center 80 m minus	1.82 m square grid with 4 columns	<d	32	31	Discrete Core (Oakfield)	19-Aug-98	ME Walsh and RN Bailey	1189	Solvent Extraction and GC	9-Sep-98
Pond 258 Center 80 m plus	1.82 m square grid with 4 columns	<d	22	31	Discrete Core (Oakfield)	19-Aug-98	ME Walsh and RN Bailey	799	Solvent Extraction and GC	9-Sep-98
Pond 258 North 0 m minus	1.82 m square grid with 4 columns	<d	36	31	Discrete Core (Oakfield)	18-Aug-98	ME Walsh and RN Bailey	1052	Solvent Extraction and GC	9-Sep-98
Pond 258 North 0 m plus	1.82 m square grid with 4 columns	<d	24	31	Discrete Core (Oakfield)	18-Aug-98	ME Walsh and RN Bailey	739	Solvent Extraction and GC	9-Sep-98
Pond 258 North 20 m minus	1.82 m square grid with 4 columns	<d	36	31	Discrete Core (Oakfield)	18-Aug-98	ME Walsh and RN Bailey	1460	Solvent Extraction and GC	9-Sep-98
Pond 258 North 20 m plus	1.82 m square grid with 4 columns	<d	32	31	Discrete Core (Oakfield)	18-Aug-98	ME Walsh and RN Bailey	1228	Solvent Extraction and GC	9-Sep-98
Pond 258 North 40 m minus and plus	1.82 m square grid with 4 columns	<d	36	31	Discrete Core (Oakfield)	18-Aug-98	ME Walsh and RN Bailey	1395	Solvent Extraction and GC	9-Sep-98
Pond 258 North 60 m minus	1.82 m square grid with 4 columns	<d	36	31	Discrete Core (Oakfield)	18-Aug-98	ME Walsh and RN Bailey	1253	Solvent Extraction and GC	9-Sep-98
Pond 258 North 60 m plus	1.82 m square grid with 4 columns	<d	40	31	Discrete Core (Oakfield)	18-Aug-98	ME Walsh and RN Bailey	1457	Solvent Extraction and GC	9-Sep-98
Pond 258 North 75 m minus	1.82 m square grid with 4 columns	<d	24	31	Discrete Core (Oakfield)	18-Aug-98	ME Walsh and RN Bailey	804	Solvent Extraction and GC	9-Sep-98
Pond 258 North 75 m plus	1.82 m square grid with 4 columns	<d	48	31	Discrete Core (Oakfield)	18-Aug-98	ME Walsh and RN Bailey	1770	Solvent Extraction and GC	9-Sep-98
Pond 258 - Line A1	Line sampled every 2 m	0.0004		31	Discrete Core (Oakfield)	26-Jun-98	CM Collins	2310	Solvent Extraction and GC	1-Jul-98
Pond 256 - Line A2	Line sampled every 2 m	<d		31	Discrete Core (Oakfield)	26-Jun-98	CM Collins	1270	Solvent Extraction and GC	1-Jul-98

Grid composite samples

	Type of composite	WP conc. ($\mu\text{g/g}$)	Number subsamples in composite	Nominal volume of sub- samples (mL)	Type of subsample	Date composite collected	Collector	Mass of composite (g)	Analysis method	Date analyzed
Pond 258 Sump Hole Rim	Line sampled every 2 m	<d		31	Discrete Core (Oakfield)	13-Jul-98	CM Collins	1130	Solvent Extrac- tion and GC	15-Jul-98
Pond 258 Outside Sump Hole	Line sampled every 2 m	<d		31	Discrete Core (Oakfield)	13-Jul-98	CM Collins	1060	Solvent Extrac- tion and GC	15-Jul-98
Pond 258 - 2m south of A1	Line sampled every 2 m	<d		31	Discrete Core (Oakfield)	13-Jul-98	CM Collins	1330	Solvent Extrac- tion and GC	15-Jul-98
Pond 258 - 4 m south of A1	Line sampled every 2 m	<d		31	Discrete Core (Oakfield)	13-Jul-98	CM Collins	1550	Solvent Extrac- tion and GC	15-Jul-98
Pond 258 - 6 m south of A1	Line sampled every 2 m	<d		31	Discrete Core (Oakfield)	13-Jul-98	CM Collins	1730	Solvent Extrac- tion and GC	15-Jul-98
Pond 258 - Target	Line sampled every 2 m	<d	24	31	Discrete Core (Oakfield)	19-Aug-98	ME Walsh and RN Bailey	1246	Solvent Extrac- tion and GC	9-Sep-98
Pond 258 - Ditch 1	Line sampled every 2 m	<d	25	31	Discrete Core (Oakfield)	19-Aug-98	ME Walsh and RN Bailey	1208	Solvent Extrac- tion and GC	9-Sep-98
Pond 258 - Ditch 2	Line sampled every 2 m	<d	22	31	Discrete Core (Oakfield)	19-Aug-98	ME Walsh and RN Bailey	767	Solvent Extrac- tion and GC	9-Sep-98
Pond 258 - Ditch 3	Line sampled every 2 m	<d	16	31	Discrete Core (Oakfield)	19-Aug-98	ME Walsh and RN Bailey	659	Solvent Extrac- tion and GC	9-Sep-98
Pond 258 - Ditch 4	Line sampled every 2 m	<d	25	31	Discrete Core (Oakfield)	19-Aug-98	ME Walsh and RN Bailey	818	Solvent Extrac- tion and GC	9-Sep-98
Pond 258 - Ditch 5	Line sampled every 2 m	<d	20	31	Discrete Core (Oakfield)	19-Aug-98	ME Walsh and RN Bailey	792	Solvent Extrac- tion and GC	9-Sep-98
Pond 258 - 258 south	Line sampled every 2 m	<d		31	Discrete Core (Oakfield)	29-Jul-98	CM Collins		Solvent Extrac- tion and GC	31-Jul-98
Pond 258 - 258 north	Line sampled every 2 m	0.0034		31	Discrete Core (Oakfield)	29-Jul-98	CM Collins		Solvent Extrac- tion and GC	31-Jul-98
Pond 290 Composites										
Pond 290 0 m Rep 1	1.82 m square grid with 4 columns	<d	92	31	Discrete Core (Oakfield)	8-Jun-98	ME Walsh and RN Bailey	3300	Solvent Extrac- tion and GC	17-Jun-98
Pond 290 0 m Rep 2	1.82 m square grid with 4 columns	<d	92	31	Discrete Core (Oakfield)	8-Jun-98	ME Walsh and RN Bailey	4300	Solvent Extrac- tion and GC	17-Jun-98
Pond 290 40 m Rep 2	1.82 m square grid with 4 columns	<d	92	31	Discrete Core (Oakfield)	8-Jun-98	ME Walsh and RN Bailey	3150	Solvent Extrac- tion and GC	17-Jun-98

Grid composite samples

	Type of composite	WP conc. (µg/g)	Number subsamples in composite	Nominal volume of subsamples (mL)	Type of subsample	Date composite collected	Collector	Mass of composite (g)	Analysis method	Date analyzed
Pond 290 40 m Rep 1	1.82 m square grid with 4 columns	<d	92	31	Discrete Core (Oakfield)	8-Jun-98	ME Walsh and RN Bailey	3700	Solvent Extraction and GC	17-Jun-98
Pond 290 80 m Rep 1	1.82 m square grid with 4 columns	<d	92	31	Discrete Core (Oakfield)	5-Jun-98	ME Walsh and RN Bailey	2950	Solvent Extraction and GC	17-Jun-98
Pond 290 80 m Rep 2	1.82 m square grid with 4 columns	<d	92	31	Discrete Core (Oakfield)	5-Jun-98	ME Walsh and RN Bailey	3650	Solvent Extraction and GC	17-Jun-98
Pond 290 120 m Rep 1	1.82 m square grid with 4 columns	<d	92	31	Discrete Core (Oakfield)	8-Jun-98	ME Walsh and RN Bailey	3200	Solvent Extraction and GC	17-Jun-98
Pond 290 120 m Rep 2	1.82 m square grid with 4 columns	<d	92	31	Discrete Core (Oakfield)	8-Jun-98	ME Walsh and RN Bailey	3650	Solvent Extraction and GC	17-Jun-98
Pond 290 160 m Rep 1	1.82 m square grid with 4 columns	<d	92	31	Discrete Core (Oakfield)	8-Jun-98	ME Walsh and RN Bailey	3350	Solvent Extraction and GC	17-Jun-98
Pond 290 160 m Rep 2	1.82 m square grid with 4 columns	<d	92	31	Discrete Core (Oakfield)	8-Jun-98	ME Walsh and RN Bailey	3050	Solvent Extraction and GC	17-Jun-98
Pond 290 South Lobe	Approximate 2 m square grid with 2 columns	<d	28	31	Discrete Core (Oakfield)	19-Aug-98	ME Walsh and RN Bailey	974	Solvent Extraction and GC	9-Sep-98
Pond 290 North Line	Line sampled every 2 m	<d	25	31	Discrete Core (Oakfield)	26-Jun-98	CM Collins	886	Solvent Extraction and GC	1-Jul-98
Pond 290 140 m Line	Line sampled every 2 m	<d	24	31	Discrete Core (Oakfield)	26-Jun-98	CM Collins	770	Solvent Extraction and GC	1-Jul-98
Racine Island Composites 1998										
Pond 293 NW Corner	Approximate 2 m square grid with 2 columns	0.106	30	31	Discrete Core (Oakfield)	24-Aug-98	ME Walsh and RN Bailey	1092	Solvent Extraction and GC	10-Sep-98
Pond 293 West	Approximate 2 m square grid with 2 columns	0.144	20	31	Discrete Core (Oakfield)	24-Aug-98	ME Walsh and RN Bailey	770	Solvent Extraction and GC	10-Sep-98
Pond 297	Approximate 2 m square grid with 2 columns	254	22	31	Discrete Core (Oakfield)	24-Aug-98	ME Walsh and RN Bailey	847	Solvent Extraction and GC	10-Sep-98
Pond 155 Composites 1998										
Pond 155 SW Grid	1.82 m square grid with 4 columns	0.0231	48	31	Discrete Core (Oakfield)	21-Aug-98	ME Walsh and RN Bailey	1783	Solvent Extraction and GC	9-Sep-98
Pond 155 NE Grid	1.82 m square grid with 4 columns	<d	48	31	Discrete Core (Oakfield)	21-Aug-98	ME Walsh and RN Bailey	1731	Solvent Extraction and GC	9-Sep-98

Grid composite samples

	Type of composite	WP conc. ($\mu\text{g/g}$)	Number subsamples in composite	Nominal volume of subsamples (mL)	Type of subsample	Date composite collected	Collector	Mass of composite (g)	Analysis method	Date analyzed
Area C										
C 100 m Composite Rep 1	1.82 m square grid with 4 columns	0.0272	92	50	Discrete Core (50 cc syringe)	4-Jun-98	ME Walsh and RN Bailey	5600	Solvent Extraction and GC	17-Jun-98
C 100 m Composite Rep 2	m square grid with 4 columns	0.0752	92	50	Discrete Core (50 cc syringe)	4-Jun-98	ME Walsh and RN Bailey	5300	Solvent Extraction and GC	17-Jun-98
C 100 m Composite Rep 3	1.82 m square grid with 4 columns	0.0188	92	50	Discrete Core (50 cc syringe)	4-Jun-98	ME Walsh and RN Bailey	5150	Solvent Extraction and GC	17-Jun-98
C 100 m Composite Rep 4	1.82 m square grid with 4 columns	0.0099	92	50	Discrete Core (50 cc syringe)	4-Jun-98	ME Walsh and RN Bailey	5300	Solvent Extraction and GC	17-Jun-98
C 100 m Composite Rep 5	1.82 m square grid with 4 columns	0.0082	92	50	Discrete Core (50 cc syringe)	4-Jun-98	ME Walsh and RN Bailey	5550	Solvent Extraction and GC	17-Jun-98
C 100 m Composite Rep 1	1.82 m square grid with 4 columns	0.0061	92	50	Discrete Core (50 cc syringe)	24-Aug-98	ME Walsh and RN Bailey	7108	Solvent Extraction and GC	3-Sep-98
C 100 m Composite Rep 2	1.82 m square grid with 4 columns	0.0084	92	50	Discrete Core (50 cc syringe)	24-Aug-98	ME Walsh and RN Bailey	6956	Solvent Extraction and GC	3-Sep-98
C 100 m Composite Rep 3	1.82 m square grid with 4 columns	0.0435	92	50	Discrete Core (50 cc syringe)	24-Aug-98	ME Walsh and RN Bailey	7196	Solvent Extraction and GC	3-Sep-98
C 100 m Composite Rep 4	1.82 m square grid with 4 columns	0.0074	92	50	Discrete Core (50 cc syringe)	24-Aug-98	ME Walsh and RN Bailey	7340	Solvent Extraction and GC	3-Sep-98
C 100 m Composite Rep 5	1.82 m square grid with 4 columns	0.0054	92	50	Discrete Core (50 cc syringe)	24-Aug-98	ME Walsh and RN Bailey	6790	Solvent Extraction and GC	3-Sep-98
BT North Composites 1998										
BT N 100 m Composite Rep 1	1.82 m square grid with 4 columns	0.0026	92	31	Discrete Core (Oakfield)	5-Jun-98	ME Walsh and RN Bailey	4050	Solvent Extraction and GC	18-Jun-98
BT N 100 m Composite Rep 2	1.82 m square grid with 4 columns	0.0038	92	31	Discrete Core (Oakfield)	5-Jun-98	ME Walsh and RN Bailey	5050	Solvent Extraction and GC	18-Jun-98
BT N 100 m Composite Rep 3	1.82 m square grid with 4 columns	0.0032	92	31	Discrete Core (Oakfield)	5-Jun-98	ME Walsh and RN Bailey	4500	Solvent Extraction and GC	18-Jun-98
BT N 100 m Composite Rep 4	1.82 m square grid with 4 columns	0.0016	92	31	Discrete Core (Oakfield)	5-Jun-98	ME Walsh and RN Bailey	6050	Solvent Extraction and GC	18-Jun-98
BT N 100 m Composite Rep 5	1.82 m square grid with 4 columns	6.58	92	31	Discrete Core (Oakfield)	5-Jun-98	ME Walsh and RN Bailey	3450	Solvent Extraction and GC	18-Jun-98

Grid composite samples

	Type of composite	WP conc. (µg/g)	Number subsamples in composite	Nominal volume of subsamples (mL)	Type of subsample	Date composite collected	Collector	Mass of composite (g)	Analysis method	Date analyzed
BT N 100 m Composite Rep 1	1.82 m square grid with 4 columns	0.00066	92	31	Discrete Core (Oakfield)	22-Aug-98	ME Walsh and RN Bailey	3480	Solvent Extraction and GC	11-Sep-98
BT N 100 m Composite Rep 2	1.82 m square grid with 4 columns	0.036	92	31	Discrete Core (Oakfield)	22-Aug-98	ME Walsh and RN Bailey	3660	Solvent Extraction and GC	11-Sep-98
BT N 100 m Composite Rep 3	1.82 m square grid with 4 columns	0.032	92	31	Discrete Core (Oakfield)	22-Aug-98	ME Walsh and RN Bailey	3590	Solvent Extraction and GC	11-Sep-98
BT N 100 m Composite Rep 4	1.82 m square grid with 4 columns	0.00062	92	31	Discrete Core (Oakfield)	22-Aug-98	ME Walsh and RN Bailey	3550	Solvent Extraction and GC	11-Sep-98
BT N 100 m Composite Rep 5	1.82 m square grid with 4 columns	0.0038	92	31	Discrete Core (Oakfield)	22-Aug-98	ME Walsh and RN Bailey	3580	Solvent Extraction and GC	11-Sep-98
BT South Composites 1998										
BT S 100 m Composite Rep 1	1.82 m square grid with 4 columns	0.0009	92	31	Discrete Core (Oakfield)	4-Jun-98	ME Walsh and RN Bailey	3100	Solvent Extraction and GC	18-Jun-98
BT S 100 m Composite Rep 2	1.82 m square grid with 4 columns	0.0009	92	31	Discrete Core (Oakfield)	4-Jun-98	ME Walsh and RN Bailey	4000	Solvent Extraction and GC	18-Jun-98
BT S 100 m Composite Rep 3	1.82 m square grid with 4 columns	0.0010	92	31	Discrete Core (Oakfield)	4-Jun-98	ME Walsh and RN Bailey	3500	Solvent Extraction and GC	18-Jun-98
BT S 100 m Composite Rep 4	1.82 m square grid with 4 columns	0.0040	92	31	Discrete Core (Oakfield)	4-Jun-98	ME Walsh and RN Bailey	4450	Solvent Extraction and GC	18-Jun-98
BT S 100 m Composite Rep 5	1.82 m square grid with 4 columns	0.0012	92	31	Discrete Core (Oakfield)	4-Jun-98	ME Walsh and RN Bailey	4350	Solvent Extraction and GC	18-Jun-98
BT S 100 m Composite Rep 1	1.82 m square grid with 4 columns	0.00096	92	31	Discrete Core (Oakfield)	22-Aug-98	ME Walsh and RN Bailey	3550	Solvent Extraction and GC	11-Sep-98
BT S 100 m Composite Rep 2	1.82 m square grid with 4 columns	0.01211	92	31	Discrete Core (Oakfield)	22-Aug-98	ME Walsh and RN Bailey	3650	Solvent Extraction and GC	11-Sep-98
BT S 100 m Composite Rep 3	1.82 m square grid with 4 columns	0.00238	92	31	Discrete Core (Oakfield)	22-Aug-98	ME Walsh and RN Bailey	3800	Solvent Extraction and GC	11-Sep-98
BT S 100 m Composite Rep 4	1.82 m square grid with 4 columns	0.00146	92	31	Discrete Core (Oakfield)	22-Aug-98	ME Walsh and RN Bailey	3870	Solvent Extraction and GC	11-Sep-98
BT S 100 m Composite Rep 5	1.82 m square grid with 4 columns	0.00076	92	31	Discrete Core (Oakfield)	22-Aug-98	ME Walsh and RN Bailey	3700	Solvent Extraction and GC	11-Sep-98

EAGLE RIVER FLATS FY 98

Subsurface sediment samples

<i>Sample</i>	<i>Depth</i>	<i>WP conc. ($\mu\text{g/g}$)</i>	<i>Data sample collected</i>	<i>Collector</i>	<i>Nominal volume collected (mL)†</i>	<i>Analysis method</i>	<i>Date analyzed</i>
Site 883	Surface	<d	21-Aug-98	ME Walsh and RN Bailey	20	Solvent extraction and GC	1-Sep-98
Site 883	5 cm	<d	21-Aug-98	ME Walsh and RN Bailey	20	Solvent extraction and GC	1-Sep-98
Site 883	10 cm	<d	21-Aug-98	ME Walsh and RN Bailey	20	Solvent extraction and GC	1-Sep-98
Site 883	15 cm	<d	21-Aug-98	ME Walsh and RN Bailey	20	Solvent extraction and GC	1-Sep-98
Site 883	20 cm	<d	21-Aug-98	ME Walsh and RN Bailey	20	Solvent extraction and GC	1-Sep-98
Site 883	25 cm	<d	21-Aug-98	ME Walsh and RN Bailey	20	Solvent extraction and GC	1-Sep-98
Site 883	30 cm	<d	21-Aug-98	ME Walsh and RN Bailey	20	Solvent extraction and GC	1-Sep-98
Site 972	Surface	<d	21-Aug-98	ME Walsh and RN Bailey	20	Solvent extraction and GC	1-Sep-98
Site 972	5 cm	<d	21-Aug-98	ME Walsh and RN Bailey	20	Solvent extraction and GC	1-Sep-98
Site 972	10 cm	0.0019	21-Aug-98	ME Walsh and RN Bailey	20	Solvent extraction and GC	1-Sep-98
Site 972	15 cm	<d	21-Aug-98	ME Walsh and RN Bailey	20	Solvent extraction and GC	1-Sep-98
Site 972	20 cm	<d	21-Aug-98	ME Walsh and RN Bailey	20	Solvent extraction and GC	1-Sep-98
Site 972	25 cm	<d	21-Aug-98	ME Walsh and RN Bailey	20	Solvent extraction and GC	1-Sep-98
Site 972	30 cm	<d	21-Aug-98	ME Walsh and RN Bailey	20	Solvent extraction and GC	1-Sep-98

III-2. TREATMENT VERIFICATION

Subsurface sediment samples

<i>Sample</i>	<i>Depth</i>	<i>WP conc. ($\mu\text{g/g}$)</i>	<i>Data sample collected</i>	<i>Collector</i>	<i>Nominal volume collected (mL)†</i>	<i>Analysis method</i>	<i>Date analyzed</i>
Near Pen 5 R11C1	Surface	0.121	21-Aug-98	ME Walsh, RN Bailey, CM Collins	20	Solvent extraction and GC	1-Sep-98
Near Pen 5 R11C1	5 cm	0.330	21-Aug-98	ME Walsh, RN Bailey, CM Collins	20	Solvent extraction and GC	1-Sep-98
Near Pen 5 R11C1	10 cm	0.0107	21-Aug-98	ME Walsh, RN Bailey, CM Collins	20	Solvent extraction and GC	1-Sep-98
Near Pen 5 R11C1	15 cm	<d	21-Aug-98	ME Walsh, RN Bailey, CM Collins	20	Solvent extraction and GC	1-Sep-98
Near Pen 5 R11C1	20 cm	<d	21-Aug-98	ME Walsh, RN Bailey, CM Collins	20	Solvent extraction and GC	1-Sep-98
Near Pen 5 R11C1	25 cm	<d	21-Aug-98	ME Walsh, RN Bailey, CM Collins	20	Solvent extraction and GC	1-Sep-98
Miller Center 1	Top half††	0.0368	25-Aug-98	ME Walsh, RN Bailey, CM Collins	31	Solvent extraction and GC	1-Sep-98
Miller Center 1	Bottom half	0.2525	25-Aug-98	ME Walsh, RN Bailey, CM Collins	31	Solvent extraction and GC	1-Sep-98
Miller Center 2	Top half	0.0009	25-Aug-98	ME Walsh, RN Bailey, CM Collins	31	Solvent extraction and GC	1-Sep-98
Miller Center 2	Bottom half	0.1001	25-Aug-98	ME Walsh, RN Bailey, CM Collins	31	Solvent extraction and GC	1-Sep-98

†Shovel used to dig hole. Syringe corer (20 cc) used to obtain core from wall of hole.

†† Miller's Hole sampled with Oakfield corer pushed down 20 cm. Actual length of each sediment core was 12 cm.

Discrete sampling 1998

<i>Sample</i>	<i>Survey ID</i>	<i>E (m)</i>	<i>N (m)</i>	<i>Elevation (m)</i>	<i>WP Conc. (µg/g)</i>	<i>Date sample collected</i>	<i>Collector</i>	<i>Volume collected (mL)</i>	<i>Analysis method</i>	<i>Date analyzed</i>
Data logger stations										
Pond 290 0 m	290-1 Tripod	354,448.16	6,800,327.11	4.66	<d	8-Jun-98	ME Walsh and RN Bailey	500	Solvent extrac- tion and GC	18-Jun-98
Pond 290 80 m	290-2 Tripod	354,389.74	6,800,382.08	4.71	<d	5-Jun-98	ME Walsh and RN Bailey	500	Solvent extrac- tion and GC	18-Jun-98
Pond 290 160 m	290-3 Tripod	354,320.27	6,800,421.78	4.67	<d	8-Jun-98	ME Walsh and RN Bailey	500	Solvent extrac- tion and GC	18-Jun-98
C 100 m	C-100 tripod	355,024.49	6,801,302.48	4.68	<d	4-Jun-98	ME Walsh and RN Bailey	500	Solvent extrac- tion and GC	18-Jun-98
BT South 100 m	'97 survey	354,521.08	6,801,724.34	4.76	<d	4-Jun-98	ME Walsh and RN Bailey	500	Solvent extrac- tion and GC	18-Jun-98
BT North 100m	Tripod BT Nort	354,536.42	6,801,826.00	4.74	<d	5-Jun-98	ME Walsh and RN Bailey	500	Solvent extrac- tion and GC	18-Jun-98
Formerly sampled sites										
BT Site 248	Old Site 248	354,528.85	6,801,818.60	4.70	<d	22-Aug-98	ME Walsh, RN Bailey, CM Collins	120	Solvent extrac- tion and GC	11-Sep-98
BT Site 359	Old Site 359	354,498.37	6,801,805.56	4.69	<d	22-Aug-98	ME Walsh, RN Bailey, CM Collins	120	Solvent extrac- tion and GC	11-Sep-98
Rac. Island Site 1246 Jar 1	Old Site 1246	355,449.14	6,800,231.42	4.58	1.70	1-Sep-98	CM Collins	500	Solvent extrac- tion and GC	18-Sep-98
Rac. Island Site 1246 Jar 2	Old Site 1246	355,449.14	6,800,231.42	4.58	87.7	1-Sep-98	CM Collins	500	Solvent extrac- tion and GC	18-Sep-98
DWRC Pen 5										
R1C1	Pen 5 R1C1	355,038.24	6,801,295.89	4.64	<d	21-Aug-98	ME Walsh, RN Bailey, CM Collins	120	Solvent extrac- tion and GC	15-Sep-98 15-Sep-98
R1C2					<d	21-Aug-98	ME Walsh, RN Bailey, CM Collins	120	Solvent extrac- tion and GC	15-Sep-98 15-Sep-98
R1C3					<d	21-Aug-98	ME Walsh, RN Bailey, CM Collins	120	Solvent extrac- tion and GC	15-Sep-98 15-Sep-98

Discrete sampling 1998

Sample	Survey ID	E (m)	N (m)	Elevation (m)	WP Conc. (µg/g)	Date sample collected	Collector	Volume collected (mL)	Analysis method	Date analyzed
R1C4	Pen 5 R1C5	355,297.87	6,801,201.32	4.63	<d	21-Aug-98	ME Walsh, RN Bailey, CM Collins	120	Solvent extraction and GC	15-Sep-98
R2C1					<d	21-Aug-98	ME Walsh, RN Bailey, CM Collins	120	Solvent extraction and GC	15-Sep-98
R2C2					<d	21-Aug-98	ME Walsh, RN Bailey, CM Collins	120	Solvent extraction and GC	15-Sep-98
R2C3					<d	21-Aug-98	ME Walsh, RN Bailey, CM Collins	120	Solvent extraction and GC	15-Sep-98
R2C4					<d	21-Aug-98	ME Walsh, RN Bailey, CM Collins	120	Solvent extraction and GC	15-Sep-98
R3C1					<d	21-Aug-98	ME Walsh, RN Bailey, CM Collins	120	Solvent extraction and GC	15-Sep-98
R3C2					<d	21-Aug-98	ME Walsh, RN Bailey, CM Collins	120	Solvent extraction and GC	15-Sep-98
R3C3					<d	21-Aug-98	ME Walsh, RN Bailey, CM Collins	120	Solvent extraction and GC	15-Sep-98
R3C4					<d	21-Aug-98	ME Walsh, RN Bailey, CM Collins	120	Solvent extraction and GC	15-Sep-98
R4C1					0.0006	21-Aug-98	ME Walsh, RN Bailey, CM Collins	120	Solvent extraction and GC	15-Sep-98
R4C2					0.0014	21-Aug-98	ME Walsh, RN Bailey, CM Collins	120	Solvent extraction and GC	15-Sep-98

Discrete sampling 1998

Sample	Survey ID	E (m)	N (m)	Elevation (m)	WP Conc. (µg/g)	Date sample collected	Collector	Volume collected (mL)	Analysis method	Date analyzed
R4C3					<d	21-Aug-98	ME Walsh, RN Bailey, CM Collins	120	Solvent extraction and GC	15-Sep-98
R4C4					<d	21-Aug-98	ME Walsh, RN Bailey, CM Collins	120	Solvent extraction and GC	15-Sep-98
R5C1					<d	21-Aug-98	ME Walsh, RN Bailey, CM Collins	120	Solvent extraction and GC	15-Sep-98
R5C2					0.0505	21-Aug-98	ME Walsh, RN Bailey, CM Collins	120	Solvent extraction and GC	15-Sep-98
R5C3					0.0067	21-Aug-98	ME Walsh, RN Bailey, CM Collins	120	Solvent extraction and GC	15-Sep-98
R5C4					0.0007	21-Aug-98	ME Walsh, RN Bailey, CM Collins	120	Solvent extraction and GC	15-Sep-98
R6C1					0.0055	21-Aug-98	ME Walsh, RN Bailey, CM Collins	120	Solvent extraction and GC	15-Sep-98
R6C2					0.0015	21-Aug-98	ME Walsh, RN Bailey, CM Collins	120	Solvent extraction and GC	15-Sep-98
R6C3					0.0042	21-Aug-98	ME Walsh, RN Bailey, CM Collins	120	Solvent extraction and GC	15-Sep-98
R6C4					<d	21-Aug-98	ME Walsh, RN Bailey, CM Collins	120	Solvent extraction and GC	15-Sep-98
R7C1					0.0048	21-Aug-98	ME Walsh, RN Bailey, CM Collins	120	Solvent extraction and GC	15-Sep-98

Discrete sampling 1998

Sample	Survey ID	E (m)	N (m)	Elevation (m)	WP Conc. (µg/g)	Date sample collected	Collector	Volume collected (mL)	Analysis method	Date analyzed
R7C2					<d	21-Aug-98	ME Walsh, RN Bailey, CM Collins	120	Solvent extraction and GC	15-Sep-98
R7C3					0.0007	21-Aug-98	ME Walsh, RN Bailey, CM Collins	120	Solvent extraction and GC	15-Sep-98
R7C4					0.0034	21-Aug-98	ME Walsh, RN Bailey, CM Collins	120	Solvent extraction and GC	15-Sep-98
R8C1					0.210	21-Aug-98	ME Walsh, RN Bailey, CM Collins	120	Solvent extraction and GC	15-Sep-98
R8C2					<d	21-Aug-98	ME Walsh, RN Bailey, CM Collins	120	Solvent extraction and GC	15-Sep-98
R8C3					<d	21-Aug-98	ME Walsh, RN Bailey, CM Collins	120	Solvent extraction and GC	15-Sep-98
R8C4					0.0037	21-Aug-98	ME Walsh, RN Bailey, CM Collins	120	Solvent extraction and GC	15-Sep-98
R9C1					0.0033	21-Aug-98	ME Walsh, RN Bailey, CM Collins	120	Solvent extraction and GC	15-Sep-98
R9C2					0.0010	21-Aug-98	ME Walsh, RN Bailey, CM Collins	120	Solvent extraction and GC	15-Sep-98
R9C3					0.0889	21-Aug-98	ME Walsh, RN Bailey, CM Collins	120	Solvent extraction and GC	15-Sep-98
R9C4					0.0010	21-Aug-98	ME Walsh, RN Bailey, CM Collins	120	Solvent extraction and GC	15-Sep-98

Discrete sampling 1998

Sample	Survey ID	E (m)	N (m)	Elevation (m)	WP Conc. (µg/g)	Date sample collected	Collector	Volume collected (mL)	Analysis method	Date analyzed
R10C1					<d	21-Aug-98	ME Walsh, RN Bailey, CM Collins	120	Solvent extraction and GC	15-Sep-98
R10C2					0.0021	21-Aug-98	ME Walsh, RN Bailey, CM Collins	120	Solvent extraction and GC	15-Sep-98
R10C3					0.1871	21-Aug-98	ME Walsh, RN Bailey, CM Collins	120	Solvent extraction and GC	15-Sep-98
R10C4					0.0530	21-Aug-98	ME Walsh, RN Bailey, CM Collins	120	Solvent extraction and GC	15-Sep-98
R11C1					0.0029	21-Aug-98	ME Walsh, RN Bailey, CM Collins	120	Solvent extraction and GC	15-Sep-98
R11C2					0.0024	21-Aug-98	ME Walsh, RN Bailey, CM Collins	120	Solvent extraction and GC	15-Sep-98
R11C3					0.840	21-Aug-98	ME Walsh, RN Bailey, CM Collins	120	Solvent extraction and GC	15-Sep-98
R11C4					0.0074	21-Aug-98	ME Walsh, RN Bailey, CM Collins	120	Solvent extraction and GC	15-Sep-98
R12C1	Pen 5 R12C1	355,024.32	6,801,310.28	4.64	0.0258	21-Aug-98	ME Walsh, RN Bailey, CM Collins	120	Solvent extraction and GC	15-Sep-98
R12C2					0.0042	21-Aug-98	ME Walsh, RN Bailey, CM Collins	120	Solvent extraction and GC	15-Sep-98
R12C3					0.0146	21-Aug-98	ME Walsh, RN Bailey, CM Collins	120	Solvent extraction and GC	15-Sep-98

Discrete sampling 1998

<i>Sample</i>	<i>Survey ID</i>	<i>E (m)</i>	<i>N (m)</i>	<i>Elevation (m)</i>	<i>WP Conc. (µg/g)</i>	<i>Date sample collected</i>	<i>Collector</i>	<i>Volume collected (mL)</i>	<i>Analysis method</i>	<i>Date analyzed</i>
R12C4	Pen 5 R12C5	355,028.31	6,801,314.03	4.63	0.0035	21-Aug-98	ME Walsh, RN Bailey, CM Collins	120	Solvent extraction and GC	15-Sep-98
Miller's Hole Rim Sample 1					<d	25-Aug-98	ME Walsh, RN Bailey, CM Collins	120	Solvent extraction and GC	1-Sep-98
Miller's Hole Rim Sample 2					<d	25-Aug-98	ME Walsh, RN Bailey, CM Collins	120	Solvent extraction and GC	1-Sep-98

III-3. WEATHER DATA FOR EAGLE RIVER FLATS

Charles M. Collins

U.S. Army Cold Regions Research and
Engineering Laboratory, Hanover, NH

INTRODUCTION

Weather and tidal activities are the two main driving forces affecting almost all physical and biological processes in Eagle River Flats. Both phenomena determine how effective any cleanup procedures will be that depend on natural drying of pond bottom sediments. A meteorological site was originally installed at the edge of the EOD pad in May 1994 (Haugen 1995) and data were collected for several seasons. Over time, however, owing to a lack of support and resources, several sensors quit or went out of calibration, making the data suspect and the station obsolete.

This spring we decided to revamp the meteorological station and update the sensors and the data collection procedures. Our objective was to put into place a state-of-the-art meteorological station that would collect all the environmental climate data needed to assess the climate conditions within Eagle River Flats. In addition we wanted to automate the data collection procedure so that timely climate data were available to all the personnel conducting research in ERF. Additionally, we want to link other dataloggers in ERF to the meteorological station so that soil moisture conditions in some of the treated ponds could also be monitored remotely, along with the climatic data. To meet this goal, a station that could be periodically polled by cell phone, with the data being downloaded automatically, was needed. A radio link would have to

be established between the meteorological station, which would serve as a base station, and remote dataloggers in the field. And finally, the downloaded data would need to be displayed in manner accessible by the research staff. A web-based home page for the ERF climatic data answered that need.

To put together a revitalized meteorological station and the web-based support pages, we turned to Mike McClane, Chief of the Met Team at CRREL. The U.S. Army TECOM Meteorological Team was a tenant organization attached to CRREL, responsible for providing meteorological services in support of CRREL-sponsored projects and tests. Mike put together the new met station described here, as well as the web-based weather data sites. Unfortunately, because of funding cuts, the Met Team at CRREL was terminated at the end of the 1998 Fiscal Year. Mike has moved on to a new position with the National Weather Service in Louisville, Kentucky.

METEOROLOGICAL STATION

The old meteorological station was disassembled and shipped back to the CRREL-Hanover. Here, all the instruments were checked out. Those that were working were recalibrated and brought back into original manufacturer's specifications. Those that were not working, or could not be calibrated to within specifications, were replaced. A 4-m tower was acquired to replace the original

2 $\frac{1}{2}$ -m tripod. This allows the wind speed and direction instrumentation to be placed higher above the ground, above any effects caused by the edge of the nearby EOD pad.

The meteorological station was set up outside the main laboratory in Hanover and run for a month to check operation of the sensors and the interface with the cell phone link. The station was disassembled, shipped to Alaska, and reassembled on-site during May 1998. The station is located near the same spot as

the previous one, a small gravel pad extending into the salt marsh off the edge of the EOD pad (Fig. III-3-1). The 4-m guyed tower has the wind anemometer mounted on top, air temperature and relative humidity sensors at 2- and 0.5-m heights, and sensors for incoming and reflected radiation and precipitation. A white Fiberglas enclosure contains the Campbell Scientific CR10 datalogger, a modem, a radio transmitter, and cell phone. The radio transmitter allowed communications

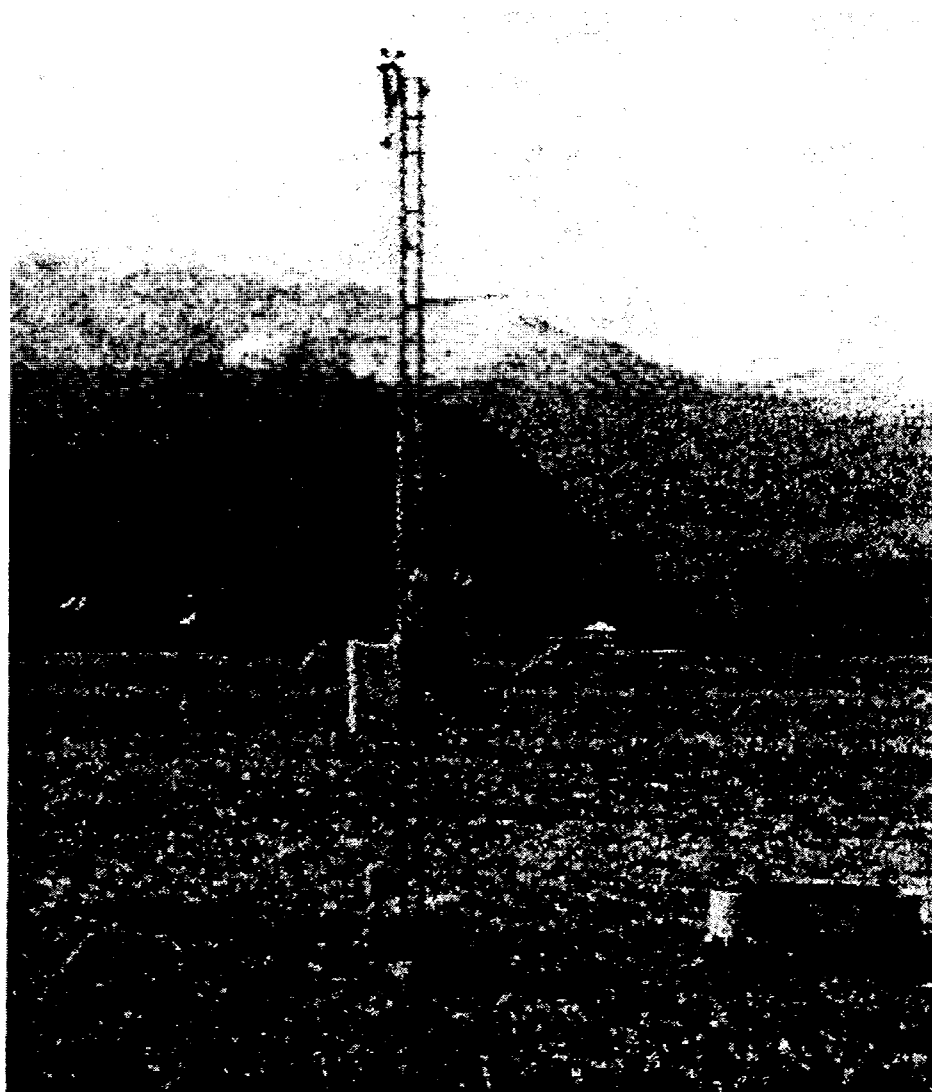

Figure III-3-1. Eagle River Flats meteorological station set up just off the edge of the EOD pad. The wind speed and direction instrumentation is located on top, and the air temperature and relative humidity sensors are located at 2 and 0.5 m height. The evaporation pan is located to the right.

Table III-3-1. Summary of meteorological station instruments and the parameters measured.

<i>Instrument</i>	<i>Parameter measured</i>
R.M. Young wind anemometer, 4 m height	Average wind speed (m/s) Average wind direction (m/s) Peak wind speed (m/s) Time of peak wind speed
(2) Air temperature sensors, 2 and 0.5 m heights	Average 2-m temperature (°C) Maximum 2-m temperature (°C) Minimum 2-m temperature (°C) Average 0.5-m temperature (°C) Maximum 0.5-m temperature (°C) Minimum 0.5-m temperature (°C)
(2) Relative humidity sensors, 2 and 0.5 m heights	Average 2-m relative humidity (%) Maximum 2-m relative humidity (%) Minimum 2-m relative humidity (%) Average 0.5-m relative humidity (%) Maximum 0.5-m relative humidity (%) Minimum 0.5-m relative humidity (%)
(2) Epply radiation (0.3–3 µm) sensors, incident and reflected	Average short wave incident radiation (W/m ²) Average short wave reflected radiation (W/m ²)
R.M. Young rain gage	Average cumulative precipitation (mm) Maximum cumulative precipitation (mm) Minimum cumulative precipitation (mm)
Tipping bucket rain gage	Tipping bucket 15-minute precipitation (mm) Tipping bucket total daily precipitation (mm)
Druck 357/D pressure transducer	Evaporation pan water level 15-minute sample Evaporation pan water level 15-minute average

between the base station and four remote datalogger sites located in treated ponds. The modem and the cell phone allowed the climatic data to be downloaded every day from the datalogger and transferred to a computer server at CRREL-Hanover. The radio antenna linking the remote dataloggers at the sediment monitoring sites is attached to the tower along with an antenna for the cell phone. A standard 1.22-m (48-in.) diameter evaporation pan is located a few meters away. A Druck pressure transducer measures the water depth in the evaporation pan. The instruments of the station are summarized in Table III-3-1. A 12-V deep cycle lead-acid battery powers the station and a solar panel mounted on the tower keeps the battery charged.

RESULTS

The meteorological station was set up and started running on 20 May 1998. The station ran the entire summer without a problem. It also served as the base station for the remote dataloggers in ERF. Data from those dataloggers were relayed through it to the computer server at CRREL, where the daily and seasonal summary data were displayed on the web page and archived in a dBaseIV database file.

Web site description

A web page site was set up initially on the *Inside CRREL* internal web site. This web site was only accessible to those on the CRREL

internal network, or those who call in from outside with authorized access. After the "bugs" were worked out, the ERF meteorological web site was also posted on the external CRREL home page and made accessible to the general public. Anyone with web access from his or her computer then could log in and view the Eagle River Flats climatic data.

After clicking on the linked button *Eagle River Flats* on either the internal CRREL home page or the external CRREL home page, an introductory index page with an aerial view of Eagle River Flats appears. After the introductory index page, the first linked page shows a daily data summary in tabular format of the meteorological station site data for the previous day. This table lists nine of the measured parameters (air temperature and relative humidity at 2 m, average air speed and wind direction, peak wind speed, incident and reflected radiation, precipitation, and evaporation pan depth) as measured every 15 minutes and a daily summary. This page was updated automatically early in the morning each day with the previous day's data. The next series of linked pages shows a series of graphs plotting the daily data. Plots are shown of the air temperature, relative humidity, wind speed, wind direction, evaporation pan water depth, cumulative daily precipitation, short wave incident and reflected radiation, and datalogger battery voltage. The third series of linked pages shows the seasonal summary plots of these data.

The fourth series of linked pages shows the

data from the monitoring sites within the treated ponds in Eagle River Flats. Data are shown for dataloggers at the Bread Truck N 100-m site, the Area C 100-m site, the Pond 290-2 site, and the Pond 258 site. For each of these, the daily tabular data showing soil temperature (maximum, minimum, and average), at both 5- and 10-cm depths, soil moisture (maximum, minimum, average at 5 and 10 cm), soil tensiometer, and water depth, if any, were shown and updated daily. These parameters were then shown as seasonal plots.

Having both the climatic data and the soil moisture and temperature data from the four remote sites available on the web allowed researchers to monitor conditions in the Flats daily, even when no one was in the field. This technology has great potential in the future for reducing the number of site visits required to monitor conditions and to ensure that equipment is functioning properly.

Climate summary

The summer of 1998 was one of the wetter summers on record, with especially heavy rainfall in late May, June, and August. Table III-3-2 is a summary of the rainfall and temperature conditions for May through August 1998, showing the monthly total rainfall for Eagle River Flats and for the National Weather Service (NWS) station at Anchorage, the normal monthly rainfall for Anchorage, the monthly average temperatures for ERF and Anchorage, and the normal monthly temperatures for Anchorage. The NWS Anchorage

Table III-3-2. Monthly summary of rainfall and temperatures for Eagle River Flats and Anchorage, showing the 1998 monthly total rainfall, the normal Anchorage rainfall, the monthly average temperatures, and the normal average temperatures for Anchorage.

Month	Rainfall (mm)			Temperature (°C)		
	Anchorage normal	Anchorage 1998	ERF 1998	Anchorage normal	Anchorage 1998	ERF 1998
May	18.5	16.0	—	8.1	8.5	—
20-31 May	9.1	1.5	8.3	9.7	10.8	9.3
June	29.0	68.6	48.7	12.4	12.6	12.0
July	43.4	25.7	33.3	14.7	14.0	13.2
August	62.0	82.6	82.2	13.5	12.1	11.0

data are presented along with the Eagle River Flats data because we do not have a long-term average for the Eagle River Flats climatic site.

May and June are normally the driest months of the core drying season needed for treatment of contaminated sediments from the pond bottoms. The late flooding tides of May eliminated any effective drying that month, and June was one of the wettest on record, with over twice the normal rainfall at the Anchorage station. Precipitation in August was also well above normal. Air temperatures were normal for the last week of May and for June but were below normal for July and August. Figure III-3-2 is a plot of the maximum, minimum, and average air temperatures for the summer. There were only 18 days during the entire summer when the maximum temperature exceeded 20°C. The radiation record (Fig. III-3-3) indicates that the skies

were cloudy for almost the entire 3 months from mid-May through August. On the plot, the approximate average daily incident radiation that would occur under clear sky conditions (i.e., the maximum possible incoming radiation) is shown as a separate curved line. For a completely sunny day, the daily average should plot near this line. Also plotted is the daily total precipitation. Rain fell regularly throughout late May and June. During early August a large rainfall event occurred on the 5th and 6th, totaling 44 mm (1.74 in.). There was another large rain event on the 21st—10.2 mm (0.41 in.).

The daily climate data for the entire summer season are summarized in Table III-3-3. The more detailed climatic data that include all the 15-minute observations are available from CRREL in an Excel spreadsheet format if needed.

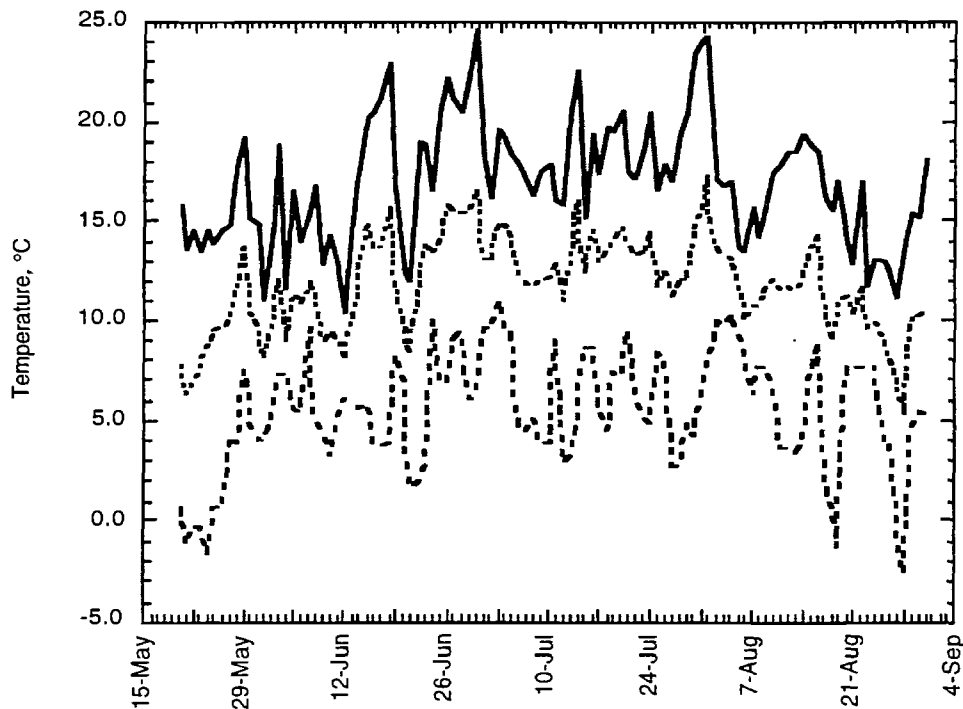

Figure III-3-2. Plot of maximum, minimum, and average daily air temperature for Eagle River Flats. There were only 18 days during the summer of 1998 with maximum temperatures over 20°C.

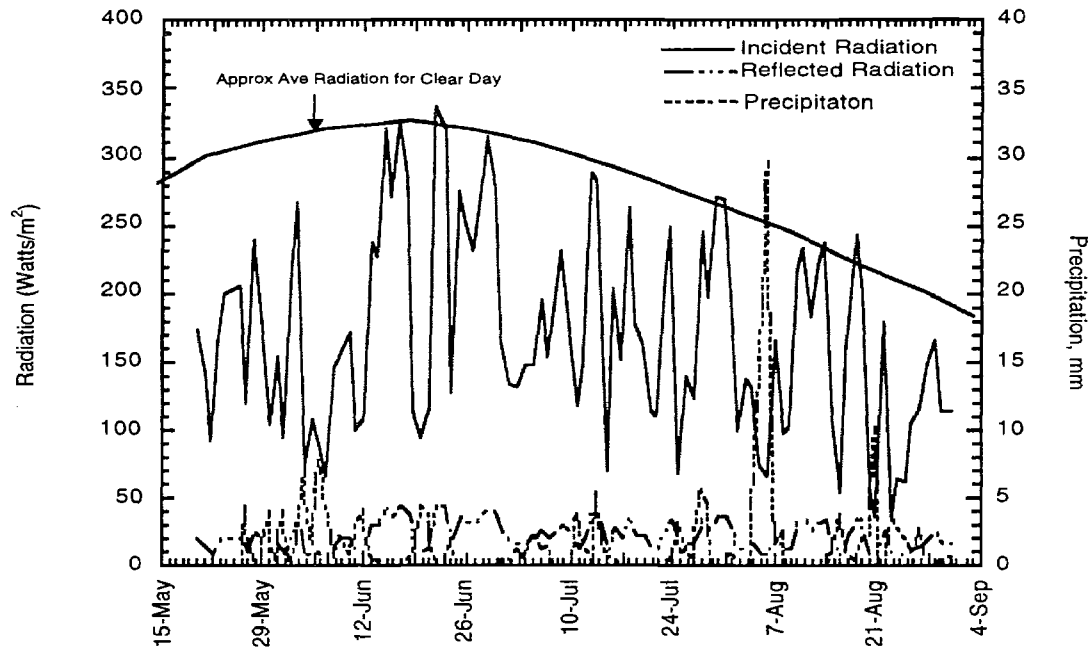

Figure III-3-3. Plot of average daily incident and reflected short wave radiation for Eagle River Flats. Also plotted is daily total precipitation. The approximate average daily incident radiation for clear sky conditions is shown as a separate curved line. For a completely sunny day, the daily average should plot near this line. The data show that there were very few sunny days during 1998.

III-3. WEATHER DATA

Table III-3-3. Daily climatic data averages for Eagle River Flats meteorological station during May–August 1998.

Date	Air temp. average (C)	RH average (%)	Wind speed average (m/s)	Wind speed maximum (m/s)	Radiation (0.3 to 3 μm)		Precip, 15-minute total (mm)	Evap. pan depth (cm)
					Incident	Reflected		
					(W/m ²)			
20-May	7.8	54	2.58	4.55	172	19	0.0	18.1
21-May	6.2	68.9	1.2	2.1	140.4	14.5	0.0	17.6
22-May	7.0	69.2	1.9	3.2	89.9	8.2	0.0	16.8
23-May	7.7	57.6	2.1	3.2	169.3	18.3	0.0	16.7
24-May	8.8	64.4	1.5	2.2	197.7	21.2	0.0	16.5
25-May	9.5	—	—	—	—	—	0.0	—
26-May	9.6	68.5	1.5	2.4	203.2	20.4	0.0	16.6
27-May	10.1	83.1	1.1	2.1	118.8	10.6	4.3	17.2
28-May	11.7	71.8	1.5	2.4	238.8	25.0	0.0	18.1
29-May	13.9	71.0	1.1	1.8	175.8	17.5	0.0	18.3
30-May	10.4	77.6	2.0	3.6	103.2	10.4	4.0	18.5
31-May	9.3	71.3	1.4	2.5	152.5	16.8	—	18.5
May avg.	9.3	—	—	—	—	—	8.30	—
1-Jun	8.0	82.9	1.3	2.3	93.3	8.9	4.0	18.5
2-Jun	10.2	74.1	1.4	2.3	214.6	24.5	0.0	19.3
3-Jun	12.2	69.2	2.1	3.4	266.9	31.6	2.0	19.1
4-Jun	9.0	89.1	0.9	1.8	73.0	6.7	7.0	19.6
5-Jun	11.3	72.5	2.1	4.1	106.5	11.0	1.5	20.1
6-Jun	10.7	89.0	0.9	1.8	91.1	8.9	7.8	20.4
7-Jun	12.0	93.1	1.0	2.2	65.5	5.6	4.5	21.9
8-Jun	11.3	71.8	2.2	3.8	143.9	17.3	0.5	22.2
9-Jun	8.9	76.8	1.6	2.7	153.1	19.0	2.3	21.9
10-Jun	9.4	74.1	1.3	2.4	169.3	20.3	0.5	22.0
11-Jun	9.0	78.7	1.2	2.1	97.8	10.6	2.3	21.7
12-Jun	8.0	88.1	1.3	2.2	106.4	10.8	4.3	22.0
13-Jun	10.4	72.2	1.4	2.4	235.4	30.2	0.3	21.8
14-Jun	11.3	68.0	1.9	3.2	226.4	29.8	0.3	21.2
15-Jun	14.9	53.9	1.7	2.9	320.4	43.1	0.0	20.7
16-Jun	13.6	62.4	1.6	2.7	270.0	37.0	0.0	20.1
17-Jun	13.6	62.5	1.4	2.5	325.9	44.4	0.0	19.5
18-Jun	15.6	57.4	1.6	2.7	280.5	37.2	0.3	19.1
19-Jun	11.9	76.8	1.8	3.2	113.3	13.6	1.0	18.7
20-Jun	9.6	86.0	1.4	2.4	92.0	9.9	4.3	18.7
21-Jun	8.2	81.6	1.8	3.1	115.8	14.0	3.8	19.2
22-Jun	11.8	61.0	1.7	2.7	335.7	45.6	0.0	19.3
23-Jun	13.9	56.2	2.1	3.5	318.6	44.6	0.0	19.0
24-Jun	13.2	76.9	1.0	1.7	127.2	15.2	2.0	18.6
25-Jun	14.0	65.9	1.1	2.0	273.5	36.2	0.0	18.6
26-Jun	15.7	61.2	1.5	2.5	251.6	34.6	0.0	18.3
27-Jun	15.4	64.7	1.9	2.9	230.0	30.8	0.0	17.8
28-Jun	15.3	67.6	1.4	2.3	274.7	37.1	0.0	17.3
29-Jun	15.6	63.4	1.4	2.3	313.8	42.5	0.0	16.8
30-Jun	16.5	66.6	1.5	2.4	275.4	36.1	0.0	16.3
June avg.	12.0	72.1	1.5	2.6	198.7	25.2	48.7	—
1-Jul	13.1	77.3	1.5	2.6	163.6	22.3	0.3	15.7
2-Jul	12.9	80.1	1.1	1.8	132.9	17.0	0.3	15.5
3-Jul	14.9	84.5	0.9	1.7	129.9	15.4	1.3	15.7
4-Jul	14.7	84.7	1.3	2.0	146.4	18.2	0.3	15.6
5-Jul	13.9	83.7	1.5	2.4	145.0	18.5	2.3	15.4
6-Jul	12.2	78.5	1.3	2.4	195.0	25.3	1.0	15.5
7-Jul	11.8	76.4	1.1	2.0	152.3	19.9	1.3	15.2
8-Jul	11.7	77.3	1.5	2.4	197.7	26.2	0.0	15.2
9-Jul	12.0	72.3	1.4	2.3	228.6	31.9	0.0	14.7
10-Jul	12.2	79.3	0.9	1.6	172.3	22.8	0.0	14.4

Table III-3-3 (cont'd). Daily climatic data averages for Eagle River Flats meteorological station during May–August 1998.

Date	Air temp. average (C)	RH average (%)	Wind speed average (m/s)	Wind speed maximum (m/s)	Radiation (0.3 to 3 μ m)		Precip. 15-minute total (mm)	Evap. pan depth (cm)
					Incident	Reflected		
					(W/m ²)			
11-Jul	12.7	81.7	1.0	1.9	116.8	14.0	3.8	14.8
12-Jul	10.9	82.7	1.2	2.0	145.2	19.5	1.3	14.8
13-Jul	13.0	75.8	1.2	2.1	287.2	40.1	0.0	14.6
14-Jul	16.0	72.3	1.5	2.5	282.8	38.2	5.3	22.2
15-Jul	12.3	89.6	0.9	1.6	68.8	8.1	0.5	28.1
16-Jul	14.5	72.7	1.5	2.5	201.3	28.2	0.5	28.1
17-Jul	12.9	75.5	1.4	2.4	152.0	20.0	0.0	27.7
18-Jul	13.5	71.1	1.4	2.3	261.8	36.9	0.0	27.4
19-Jul	14.0	72.8	1.0	1.8	175.5	23.4	0.3	27.1
20-Jul	14.6	68.0	1.6	2.8	162.8	22.1	0.0	26.7
21-Jul	13.7	81.0	0.8	1.5	112.2	13.9	0.0	26.4
22-Jul	13.2	81.0	0.9	1.7	107.5	13.4	0.0	26.2
23-Jul	13.3	67.6	1.2	2.1	203.4	26.7	0.0	26.1
24-Jul	14.4	59.4	1.7	3.0	247.3	35.1	0.3	25.6
25-Jul	11.7	83.2	1.4	2.5	66.4	8.1	3.0	25.3
26-Jul	12.4	82.3	1.0	1.7	139.9	17.3	1.0	25.8
27-Jul	11.1	80.2	1.0	1.8	123.0	16.9	0.3	25.9
28-Jul	12.1	79.9	1.3	2.3	245.1	33.7	5.6	26.2
29-Jul	12.0	84.9	1.1	2.2	195.9	24.9	4.6	27.2
30-Jul	14.2	73.9	1.0	1.9	270.8	36.8	0.0	28.7
31-Jul	15.8	71.2	1.3	2.1	268.1	37.0	0.0	30.1
July avg.	13.2	77.4	1.2	2.1	177.3	23.6	33.3	—
1-Aug	17.2	63.1	1.8	3.1	211.5	28.4	1.0	29.5
2-Aug	13.6	80.2	1.2	2.2	98.8	11.9	0.0	30.0
3-Aug	13.3	78.0	1.1	1.9	136.2	17.2	0.0	29.8
4-Aug	13.0	80.8	1.1	1.8	131.0	16.9	1.0	29.5
5-Aug	11.6	92.5	0.7	1.4	72.7	7.9	14.5	29.9
6-Aug	10.0	92.6	0.8	1.6	65.9	7.4	29.7	31.7
7-Aug	10.6	86.3	0.9	1.6	163.7	21.2	1.3	33.6
8-Aug	10.7	87.6	0.7	1.5	95.6	11.7	2.5	33.9
9-Aug	11.6	80.9	0.9	1.6	100.7	12.6	0.0	33.8
10-Aug	12.1	76.8	1.2	2.1	216.4	31.8	0.0	34.0
11-Aug	11.5	76.6	1.2	2.0	232.6	35.0	0.0	33.9
12-Aug	11.6	76.9	1.1	1.8	181.3	26.4	0.0	33.3
13-Aug	11.5	77.1	1.2	1.9	221.7	32.8	0.0	33.4
14-Aug	12.1	72.8	1.1	2.0	236.6	35.7	0.0	33.2
15-Aug	13.6	78.5	1.0	2.0	107.0	14.6	0.8	32.9
16-Aug	14.3	68.3	5.0	8.0	53.0	7.0	3.8	32.9
17-Aug	10.6	67.2	3.0	4.8	159.2	23.7	0.8	32.6
18-Aug	9.0	66.1	1.1	2.1	240.8	37.7	0.0	32.6
19-Aug	10.9	62.4	1.8	3.4	202.4	30.7	1.8	32.4
20-Aug	11.2	70.9	2.2	4.0	55.8	6.6	2.0	32.2
21-Aug	10.4	90.0	0.8	1.6	34.8	3.4	10.2	32.5
22-Aug	11.7	79.6	1.2	2.2	177.7	26.9	0.0	33.8
23-Aug	9.6	89.8	0.9	1.9	33.1	3.3	3.6	33.6
24-Aug	9.8	91.1	1.1	1.8	62.8	6.9	2.8	34.1
25-Aug	8.9	83.9	1.5	2.9	60.6	7.1	2.0	34.4
26-Aug	7.9	82.4	1.1	2.1	101.9	13.2	0.8	34.5
27-Aug	6.3	84.9	1.2	2.3	115.7	15.1	2.8	34.7
28-Aug	5.3	80.2	1.4	2.4	145.7	20.4	0.0	34.5
29-Aug	10.2	62.1	2.2	3.7	164.8	25.1	0.0	34.8
30-Aug	10.2	76.0	1.4	2.5	112.7	15.4	0.3	34.7
31-Aug	10.6	73.3	1.9	4.0	113.1	16.2	0.5	34.6
August avg.	11.0	78.3	1.4	2.5	132.4	18.4	82.2	—

REFERENCES

- Haugen, R.K.** (1995) Climate and tides. In Interagency expanded site investigation: Evaluation of white phosphorus contamination and potential treatability at Eagle River Flats, Alaska (C.H. Racine and D. Cate, Eds.). FY94 Final Report. CRREL Contract Report to U.S. Army, Alaska, Directorate of Public Works. Vol. 1, p. 187-200.

IV-1. MONITORING PHYSICAL AND BIOLOGICAL CHANGES IN EAGLE RIVER FLATS

Charles H. Racine, Edward F. Chacho, Brian Tracy, and Peter Berger
U.S. Army Cold Regions Research and Engineering Laboratory,
Hanover, N.H.

INTRODUCTION

The purpose of this study is to develop and apply remote sensing and ground-based methods for monitoring physical and biological changes in Eagle River Flats. ERF is a dynamic ecosystem, where change has been caused in the past by both human and natural disturbances. Natural disturbances and forces include high tidal ranges (11 m) and associated flooding, high erosion rates in some tidal creeks, high sedimentation rates, a subarctic coastal climate involving ice forces, and an active tectonic setting (most recently from the 1964 earthquake resulting in subsidence of 0.6 to 0.7 m). Human disturbances at ERF include extensive surface cratering, introduction of white phosphorus particles, and dumping of derelict vehicles and other debris, all related to U.S. Army artillery training over the past 40 years.

More recently, beginning in 1995, remediation of WP contamination has involved pond drainage or dewatering to expose bottom sediments to drying so that WP particles will sublime (M.E. Walsh et al. 1996). This is accomplished using either drainage ditches constructed with explosives or large floating pumps installed in a sump hole blasted into the pond bottom. The pond water is pumped through long hoses to nearby tidal creeks. Such pond dewatering has altered the flooding regime, soil moisture conditions, and hydroperiod in treated ponds (M.E. Walsh et al., this volume).

A major objective of this study is to deter-

mine how this pond remediation affects habitat, soil, and vegetation in these ponds. These changes can influence both the remediation success and the ability to restore the wetland habitat once remediation is completed (Barrett and Niering 1993). The second objective is to monitor headward and lateral erosion of tidal creek gullies. This process has been identified by Lawson et al. (1996) as a major factor that could result in pond drainage similar to that produced by blasting ditches.

STUDY SITES

In this report, we begin to monitor habitat and vegetation change in relation to pond drainage in several ponds on the east side of Eagle River (Fig. IV-1-1): 1) the Bread Truck Pond (109), ditched by explosives in spring 1996; 2) C Pond, pumped during both the summers of 1997 and 1998; 3) Clunie Pond (146), partly dredged in 1995 and then pumped during summer 1998; and 4) Lawson Pond (155), pumped during summer 1998. In addition we measure erosional change in four gullies, with the emphasis on B-Gully (Fig. IV-1-1).

METHODS

In Eagle River Flats, physical and biological changes were monitored using two different methods: 1) plot sampling and photographing vegetation in relocatable plots

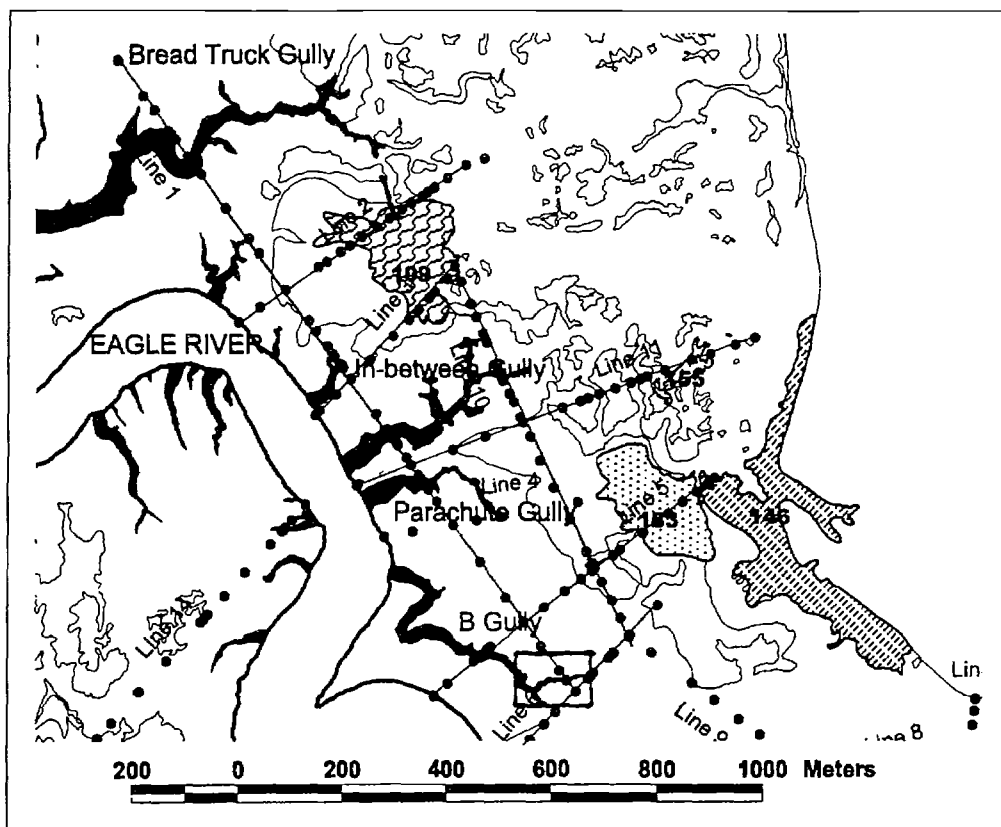

Figure IV-1-1. Map of study area showing ponds being treated and monitored on the east side of Eagle River. Also shown are locations of line transects and associated plots sampled in 1993. Gullies where erosion is being monitored are shown and named. Outlined head of B-Gully near bottom of map shows where we tested remote-sensing-GIS analysis of gully erosion.

before and after pond drainage, and 2) remote sensing using aerial photos and multispectral imagery and GIS databases to detect changes in habitat, vegetation, and gully erosion.

Plot sampling

In 1992–93, 21 line transects containing over 400 plots were marked with lathe and the vegetation cover was sampled in 1- × 1-m plots. At least six of these transects (lines 2, 3, 4, 5, 6, and 11) occur within the treated pond areas shown on Figure IV-1-1. In May and August 1998, we attempted to relocate and resample some of these plots on lines 5 and 11 in Ponds 183 and 155 (Fig. IV-1-1). The original lathe marking these plots had been carried away by tides and ice, and it was therefore necessary to relocate these original plots by navigating to them (using originally surveyed coordinates) with a GPS in real-time

mode. Problems with the GPS equipment made this difficult, although the problem will be rectified in the future.

Remote sensing

Another method for monitoring change is the comparison of aerial photos and other imagery of the same site obtained at different times. Although remote sensing methods reduce the amount of time spent on the ground and therefore risk from UXOs, some “ground truth” work is essential. The ERF GIS image library currently contains about 36 items, including aerial photos and multispectral imagery archived on disk (scanned) and on file as photos at the CRREL Eagle River Flats GIS laboratory in Hanover. There are three images from the 1950s, three from the 60s, five from the 70s, five from the 80s and about 20 from the 1990s, covering each year from 1990 to 1998.

We analyzed selected images from the 1990s to detect and measure erosional and vegetation cover changes. In most cases image analysis does not permit the identification of changes in plant species composition. Two methods of vegetation "change analysis" were used here: 1) visual inspection of color infrared paired photos of treated ponds before and after drainage and 2) computer-based spectral analysis of digital multispectral video (DMSV) images from 1995, 1997, and 1998. In this latter method, DMSV images were georeferenced and band subtraction methods were used to compare changes in the reflection of the 770-nm band in treated pond areas. This band is sensitive to vegetation cover and health.

A method for monitoring tidal creek erosion was developed using remote sensing and GIS techniques supported by ground-based GPS. The eroded scarp edge of four tidal creeks (Fig. IV-1-1) was first "mapped" by walking along the edge with a Trimble Pathfinder Pro XR GPS. Because the GPS received corrections from a Coast Guard beacon on Cook Inlet, we obtained real-time corrected line files. (We also used files from a base station on Ft. Richardson to further post-correct these files.) This GPS file was then used in ARCVIEW to georeference a scanned (600 dpi) color IR aerial photo obtained in August 1998 that covered the area of the four tidal creeks. Once scanned, this photo was used to georeference two other scanned color IR photos from 21 July 1991 and 16 August 1995. A software package add-on for ARCVIEW, called "TAS Professional" (produced by Civitas Software), was used to georeference the photos. The outline of B-Gully was then digitized from each of these three georeferenced photos in ARCVIEW. These outlines for each of the 3 years could then be overlaid and erosional change compared among the 3 years.

RESULTS

Vegetation change

Field sampling, observation, and comparisons of images before and after pond drainage showed a few major changes in the veg-

etation in permanent ponds drained by pumping or ditching (Fig. IV-1-1). Submerged aquatic species such as pondweed (*Potamogeton pectinatus*), *Zinnichellia spiralis*, and ditch grass (*Ruppia maritima*) are now absent, a not unexpected result given the absence of water. In addition, ground observations and comparison of color IR photos of Pond 183 from August 1995 with August 1998 (Fig. IV-1-2) show the loss of 10 to 20 circular colonies of the emergent species, four-leaved mare's tail (*Hippurus tetraphylla*) on the east side of the pond. By August 1998, Pond 183 had been pumped for two summers with considerable success in the reduction of white phosphorus levels (M.E. Walsh et al., this volume). Four-leaved mare's tail still survives in a reduced condition in Bread Truck Pond, which was ditched in 1995 but is flooded with tides above 4.6 m (C. Collins, pers. com.). Seeds of this species (Fig. IV-1-3) have been found in the gizzards of poisoned waterfowl and in the pond sediments.

There is some evidence from sampling that, with the lowering of the water table by pumping during summer 1998, there has been an expansion of emergent brown bulrush (*Scirpus paludosus*) and *Carex Lyngbyei* into Pond 155 (Lawson's Pond) (Fig. IV-1-4). The same type of vegetation expansion is suggested by comparison of the 1995 and 1998 color IR aerial photos (Fig. IV-1-5) of Clunie Pond (146). The same two species have expanded here, with the addition of Mackenzie's sedge (*Carex mackenziei*), formerly growing on the edge of this pond.

In several plots, weedy species previously restricted to mudflat sites, such as orache (*Atriplex patula*), have invaded the pond-marsh zone in and bordering these drained ponds.

Change in vegetation cover or health can also be evaluated on multispectral images by comparing the changes in reflectance of the IR band (770 or 990 nm). A simple way of doing this is to assign the 770-nm reflectance in a later year (1997) to the red color band and the 770-nm reflectances in an earlier year (1995) to the green and blue bands for each pixel. If the reflectance and therefore vegetation cover or health has not changed from



Figure IV-1-2. Color IR aerial photos of C Pond in August 1995 (top) before pumping began and in August 1998 (bottom) after two summers of pond pumping. Note loss of round colonies of four-leaved mare's tail.

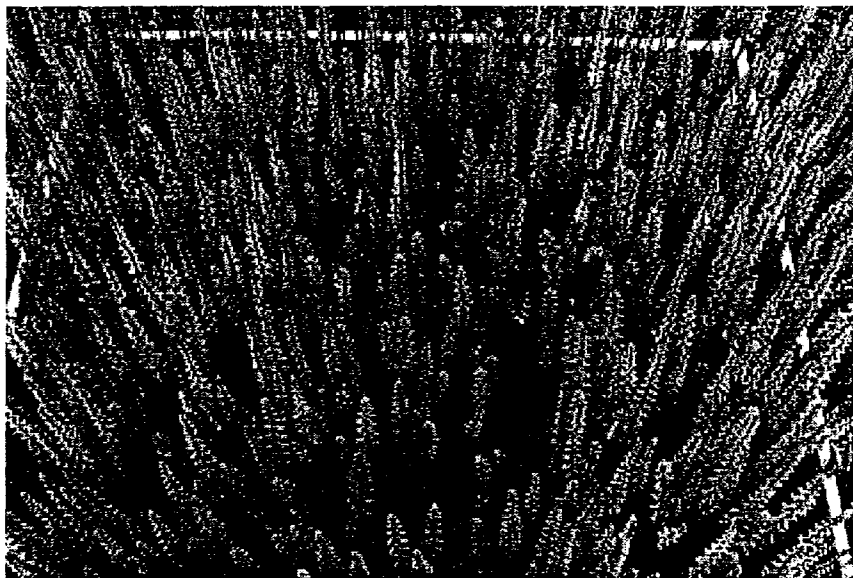

Figure IV-1-3. View down into a portion of a 1- × 1-m sample plot with four-leaved mare's tail (*Hippuris tetraphylla*) in C Pond before pumping. This species died back following 2 years of pond pumping and drying.

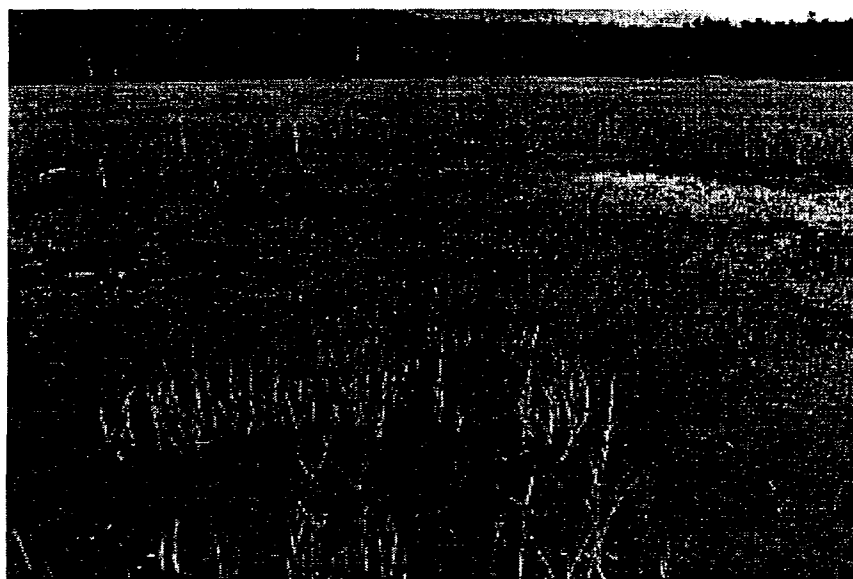

Figure IV-1-4. Pond 155 (Lawson's pond) on 26 August 1998, following one summer of pumping. Submerged aquatic species have disappeared and invasion of pond by sedges is evident in photo.



Figure IV-1-5. Color IR aerial photos of Pond 146 (Clunie Pond) in August 1995 (top) before pumping and in August 1998 (bottom) after partial dredging (area with water in bottom photo) and one summer of pumping. Note sedge vegetation expansion at the southern end of this pond. Original extent of pond is outlined on the bottom August 1998 photo.

1995 to 1997, then the values for red, green and blue will all be the same and no color will be evident. However, if in a given pixel (1.5- \times 1.5-m area), the 1997 reflectance has increased or decreased over that in 1995, the

pixels will be red. Figure IV-1-6 shows the results of this type of change assessment for the area in Figure IV-1-1.

Another remote sensing method for evaluating vegetation cover and health is the cal-



Figure IV-1-6. Change assessment image of northeastern ERF produced from 1995 and 1997 DMSV images by assigning band 770 (near-infrared NIR) reflectance 1997 to red and NIR 1995 to both green and blue. Red area shows difference in NIR reflection between 1995 and 1997.

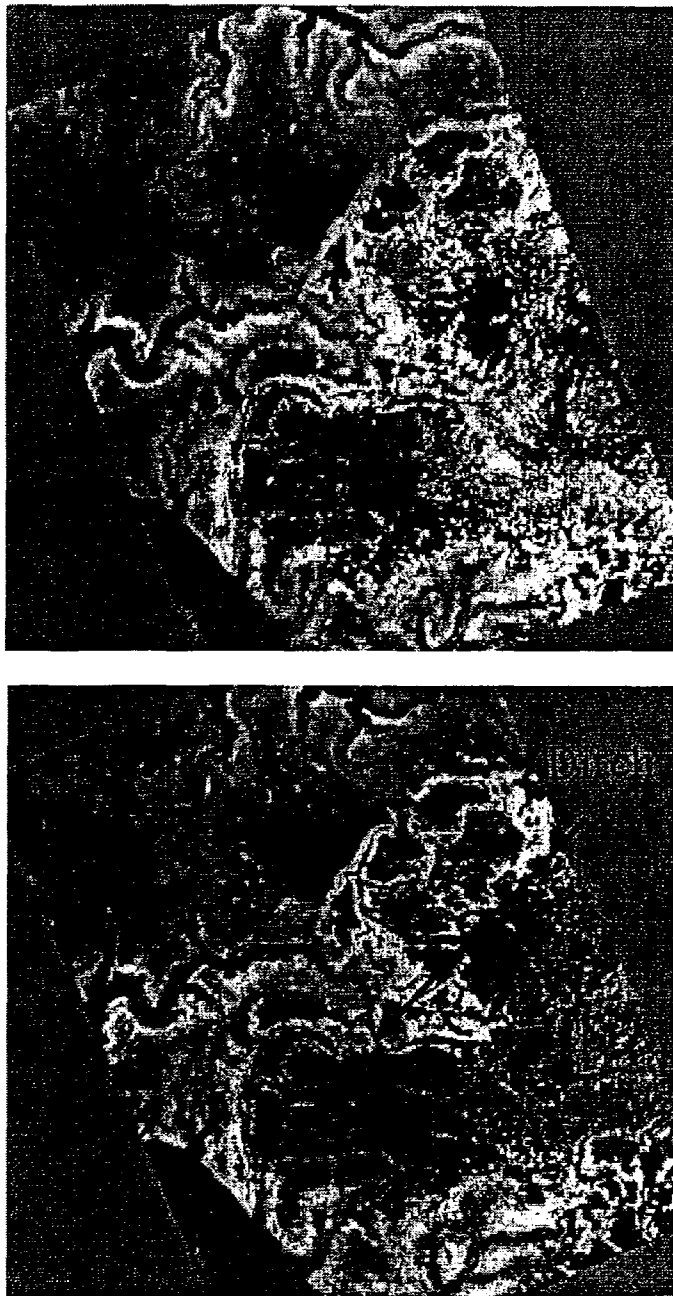

Figure IV-1-7. NDVI (normalized difference vegetation index) showing change in brightness of area just east of Bread Truck Pond (red area in Fig. IV-1-6) from 1995 (top) to 1998 (bottom). Change suggests loss of vegetation cover in part of the change area in Figure IV-1-6.

culuation of a greenness index based on the reflectance of solar radiation in the near infrared (NIR) and red bands (RED) (on our images, the 770- and 650-nm bands). This normalized difference vegetation index or NDVI was calculated as $NDVI = (NIR - RED) / (NIR$

$+ RED)$ in ERDAS Imagine for each pixel in an area in the top left of Figure IV-1-6 from a 1995 and 1998 DMSV image (Fig. IV-1-7). A low value indicates low vegetation cover and appears as dark on the images, while a high value is bright white. Comparison of these



Figure IV-1-8. Photo at the head of an eroding tidal creek looking down the gully toward Eagle River. Note rotational slumps along walls of gully.

NDVI images from 1995 and 1998 (Fig. IV-1-7) suggests a decrease in vegetation cover or health in the area east of Bread Truck Pond (109) in the same area of change identified in Figure IV-1-6.

Tidal creek erosion

Rapid headward and lateral erosion of tidal creeks or gullies in ERF was monitored by Lawson et al. (1996) (Fig. IV-1-8) using field measurement techniques. Remote sensing, using a time sequence of aerial photos, is tested here as a cost-effective and low-risk means of monitoring tidal creek erosion. Georeferenced scanned color IR photos from 1991, 1995, and 1998 were used in ARCVIEW to digitize the outline of B-Gully (Fig. IV-1-1) in each year (Fig. IV-1-9). The three outlines for each year were then overlaid in ARCVIEW to measure the extent of erosional change in this gully (Fig. IV-1-10). Between August 1991 and August 1995, the headward erosion in this gully was almost 64 m; from 1995 to 1998, an additional 13 m of headward erosion occurred (Fig. IV-1-10). Lateral erosion can also be monitored using the digitized outline of the gully in 1991, 1995, and 1998 (Fig. IV-1-10). By creating polygons out of each of the yearly outlines, it would be possible to integrate the total amount of lateral and headward erosion in a gully.

We compared lateral erosional change from fall 1995 to fall 1998 as measured by "field" vs. "remote sensing" techniques. A 45-m-long edge of B-gully shown in Figures IV-1-9 and IV-1-10 was used where Lawson et al. (1996) had established a permanent hub stake and 12 line stakes in June 1992 to measure yearly changes in distances from the hub stake to the gully edge. The decrease in distance over time is equal to the amount of lateral erosion that had occurred at that point during that time interval (Table IV-1-1). Lawson et al. (1996) measured distances on B-Gully in October 1995, about 1 month after the 1995 aerial photo used here was obtained (Table IV-1-1). We remeasured the same distances in August 1998 to determine the amount of erosion between 1995 and 1998 (Table IV-1-1). In ARCVIEW we located the surveyed hub stake and the 12 lines on the overlaid gully edges for 1995 and 1998, digitized from the georeferenced photos (Fig. IV-1-10). In ARCVIEW we then measured the distance from the 1995 line to the 1998 line to the nearest 0.5 m (Table IV-1-1). These distances are compared with those measured on the ground in Table IV-1-1 and show similar values. Although we measured change from the digitized lines to the nearest 0.5 m as compared with more precise measurements on the

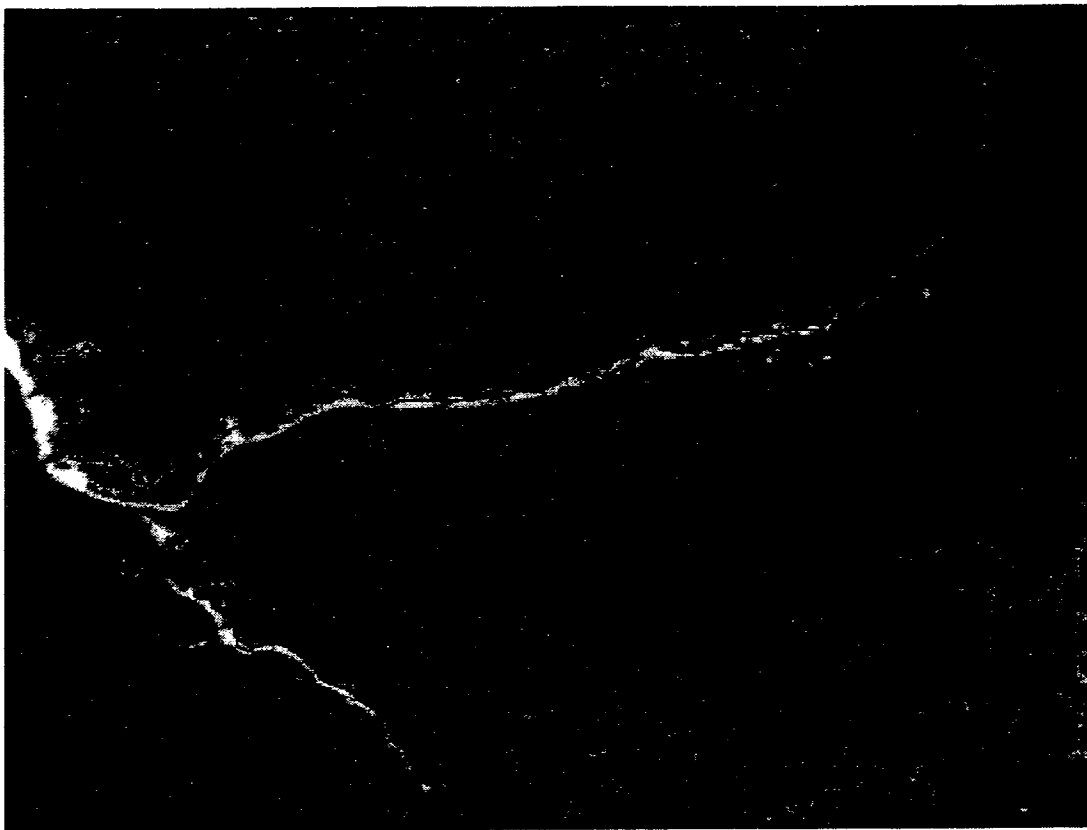

Figure IV-1-9. August 1998 scanned and georeferenced vertical aerial photo of the head of B-Gully showing its outlined edges as digitized on this photo and on scanned and georeferenced photos from 1991 and 1995. Location where lateral erosion was monitored by Lawson et al. (1996) is also shown. Black holes are water-filled craters.

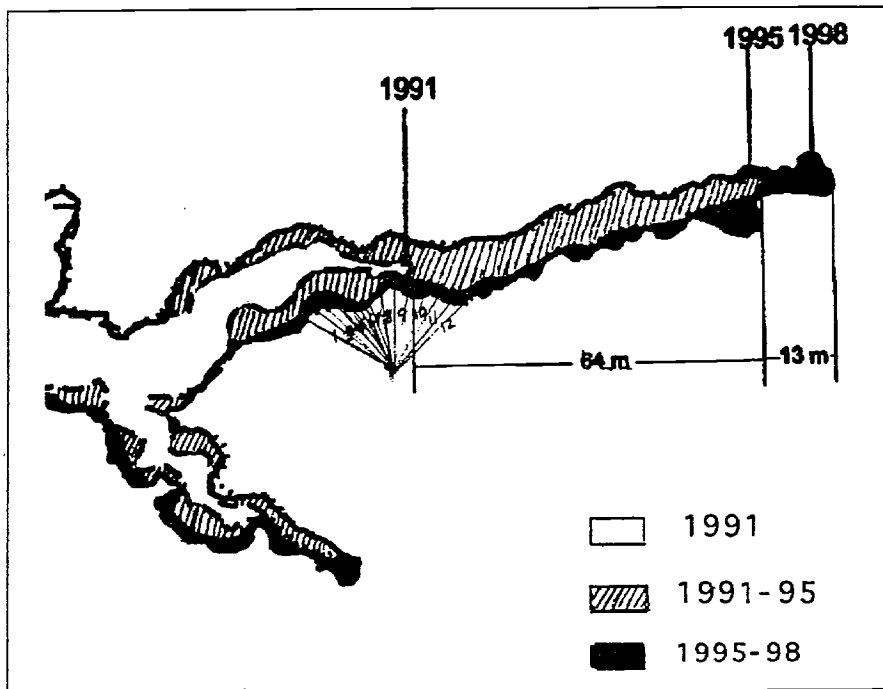

Figure IV-1-10. Digitized outlines of the tidal creek gully (B-Gully) from July of 1991, 15 August 1995 and 18 August 1998. Areas eroded in 1991 (white), between 1991 and 1995 (shaded), and between 1995 and 1998 (black). Also section of gully where lateral erosion was monitored is shown as hub and lines.

Table IV-1-1. Amount of lateral erosion on a 45-m section of B-Gully as measured in field using distances to the gully edge from permanent stakes by L. Hunter (CRREL) in fall 1995, and by this study in fall 1998. Compared with change measured from georeferenced aerial photos from August 1995 and August 1998.

<i>Stake no. (from Hub 132)</i>	<i>Distance 10/30/95</i>	<i>Distance 8/25/98</i>	<i>Field measured erosion (m)</i>	<i>Georef photo measured (m)</i>
120	18.97	18.26	0.71	1.0
121	18.89	17.90	0.99	1.0
122	19.71	17.40	2.31	2.0
123	17.82	16.20	1.62	1.5
124	15.49	14.63	0.86	1.0
125	12.88	12.18	0.70	0.5
126	12.94	12.68	0.26	0
127	16.79	15.30	1.49	1.5
128	15.37	13.82	1.55	1.5
129	16.04	14.85	1.19	1
130	16.95	15.50	1.45	1.5
131	22.08	17.35	4.73	5.0
Average (m)			1.49	1.46

*Hub at easting 354,882.84 and 6800939.35 northing.

ground, the average for the 12 points was very similar (1.49 vs. 1.46 m) for the two methods.

By use of the GPS unit with real time corrections broadcast by the Coast Guard, it is also possible to quickly map the edge of gully scarps by walking along the edge with the GPS antennae. An example of comparing the 1998 GPS outline of In-Between Gully with the outline of this gully mapped from 1993 shows that headward erosion during this period has equaled about 45 m, which is in close agreement with 42 m determined by direct measurement by Lawson et al. (1996).

DISCUSSION AND CONCLUSIONS

Methods for monitoring physical and biological change in ERF were developed and tested. While some field ground truth is necessary, imagery obtained via remote sensing techniques in mid-August of each year offers a cost-effective and reduced-risk method for monitoring change. Only preliminary data

were obtained this year, but some trends in vegetation and erosional change were observed and measured.

Aquatic habitat has essentially been lost on all treated ponds, as would be expected following pond dewatering. Reductions in aquatic macrophytes and some emergent species were documented in the ponds and spectral change analysis suggests that vegetation cover has been lost in an area bordering the inside of two ponds, one of which was ditched and the other pumped. However, in two small but deep permanent ponds with organic bottom sediments, emergent sedge vegetation appears to have expanded rapidly, although aquatic species were eliminated. This expansion of vegetation cover in such ponds may have the disadvantage of reducing sediment drying (M.E. Walsh et al. 1996).

The remote-sensing-GPS methods, demonstrated here for measuring tidal gully erosion, are efficient and greatly reduce the amount of ground measurements of the type conducted by Lawson et al. (1996). The remote

sensing methods used here may not be able to detect small changes of 0.5 m or less, but if conducted at 3- to 4-year intervals, will provide a good estimate of erosional change and can even integrate both lateral and headward change over the entire tidal creek. One could also use GPS methods to detect changes of 0.5 m by walking the edges of gullies annually. All four gullies shown in Figure IV-1-1 were walked in a day and a half. This method is more expensive and time consuming than georeferencing aerial photos and digitizing the scarp edge.

The 1998 work on change detection at ERF suggests future refinements of methods and needs. Permanent plots need to be established and monitored because of the difficulty of relocating earlier plots. Another item that should be monitored in the future is changes in the salinity of sediments in the bottom of drained ponds. The development of hypersaline sediments in these ponds could jeopardize the reestablishment of vegetation and invertebrates. Studies in other northern salt marshes have shown that vegetation removal by foraging snow geese leads to widespread soil salinity increases and "desertification" (Jano et al. 1998, Srivastava and Jeffries 1996).

In terms of pond habitat restoration, it would be useful to know if buried seeds, aquatic macrophyte corms, and rhizomes of four-leaved mare's tail in the bottom sediments of ponds remain viable during the pumping and draining period. Based on studies we conducted in the early 1990s, it is known that large amounts of seeds are stored in the bottom sediments of these ponds. If these propagules remain viable, they could provide sources for the reestablishment of some species lost as the result of pond drainage.

REFERENCES

- Barrett, N.E., and W.A. Niering** (1993) Tidal marsh restoration: Trends in vegetation change using a Geographical Information System (GIS). *Restoration Ecology*.
- Bertness, M.D., L Gough, and S.W. Shumway** (1992) Salt tolerance and the distribution of fugitive salt marsh plants. *Ecology*, 73: 1842-1851.
- Jano, A.P., R.L. Jefferies, and R.F. Rockwell** (1998) The detection of vegetational change by multitemporal analysis of LANDSAT data: the effects of goose foraging. *Journal of Ecology*, 86: 93-99.
- Lawson, D.E., L.E. Hunter, and S.R. Bigl** (1996) Physical processes and natural attenuation alternatives for remediation of white phosphorus contamination, Eagle River Flats, Fort Richardson, Alaska. CRREL Report 96-13.
- Lawson, D.E., L.E. Hunter, S. Bigl, B.M. Nadeau, P. Weyrick, and J.H. Bodette** (1996) Physical system dynamics and white phosphorus fate and transport, 1994, Eagle River Flats, Fort Richardson, Alaska. CRREL Report 96-9.
- Reed, D.J.** (1995) The response of coastal marshes to sea-level rise. *Surface Processes and Landforms*, 20: 39-48.
- Srivastava, D.S., and R.L. Jefferies** (1996) A positive feedback: herbivory, plant growth, salinity, and the desertification of an Arctic salt-marsh. *Journal of Ecology*, 84: 31-42.
- Thilenius, J.F.** (1995) Phytosociology and succession on earthquake-uplifted coastal wetlands, Copper River Delta, Alaska. USDA Forest Service, Pacific NW Research Station, PNW-GTR-346.
- Walsh, M.E., C.M. Collins, and C.H. Racine** (1996) Persistence of white phosphorus particles in salt marsh sediments. *Environmental Toxicology and Chemistry*, 15: 846-855.

IV-2. DATABASE FOR MONITORING REMEDATION EFFORTS AND SUCCESS AT EAGLE RIVER FLATS

Charles H. Racine and Peter Berger

U.S. Army Cold Regions Research and Engineering Laboratory,
Hanover, N.H.

INTRODUCTION

The Eagle River Flats geographic information system (GIS) database was originally developed in 1993 to centralize all the data collected by researchers into a spatial context. Figure IV-2-1 shows the structure and libraries in the database. Over 100 coverages currently reside in the database in six libraries, including physical and biological features, white phosphorus, waterfowl, remediation, monitoring, and images.

This GIS database has become a powerful tool for a number of applications at Eagle River Flats. It was initially used extensively to identify ponds. Now, as these WP-contaminated ponds are treated by various methods, it is being developed to 1) track remediation treatments in relation to the sites treated, methods used, and dates applied; 2) evaluate the success of these treatments in terms of changes in water levels, soil moisture, and temperature; 3) compare WP sampling results obtained by M.E. Walsh and C.M. Collins in their annual monitoring of WP concentration changes; and 4) analyze waterfowl movements and mortality. The following report describes efforts made during 1998 to use, revise, and update the database.

METHODS

The ERF GIS database is currently maintained at CRREL in Hanover, N.H., in both a

tabular format and in GIS formats, both in ARC/INFO 7.1 on a Sun Unix workstation and on a PC running ARCVIEW 3.1. Other hardware being used to facilitate database construction includes a Microtec scanner, an Altec Digitizer, and a Trimble Pathfinder XR GPS system. The data are obtained annually in tabular form from the research groups in Eagle River Flats and converted into GIS coverages. The accuracy of each new coverage is checked by the originator of the data. All features are in UTM format and NAD 27 projection. Positions are obtained from surveyed locations or real-time and post-corrected GPS, with an accuracy of ± 0.5 m. In the case of waterfowl, telemetry positions are obtained by triangulation using radio receivers. During 1998, several new database coverages were developed and new imagery was added to the image library. The complete database is currently being duplicated onto CD-ROM disks for distribution.

RESULTS

The new coverages that were revised and produced in 1998 are described below in relation to the libraries shown in Figure IV-2-1.

Remediation library (PNDREMD)

PNDREMD contains pond polygons that have been treated by one or more remediation techniques. Attributes include pond id number, area, method, method used, person re-

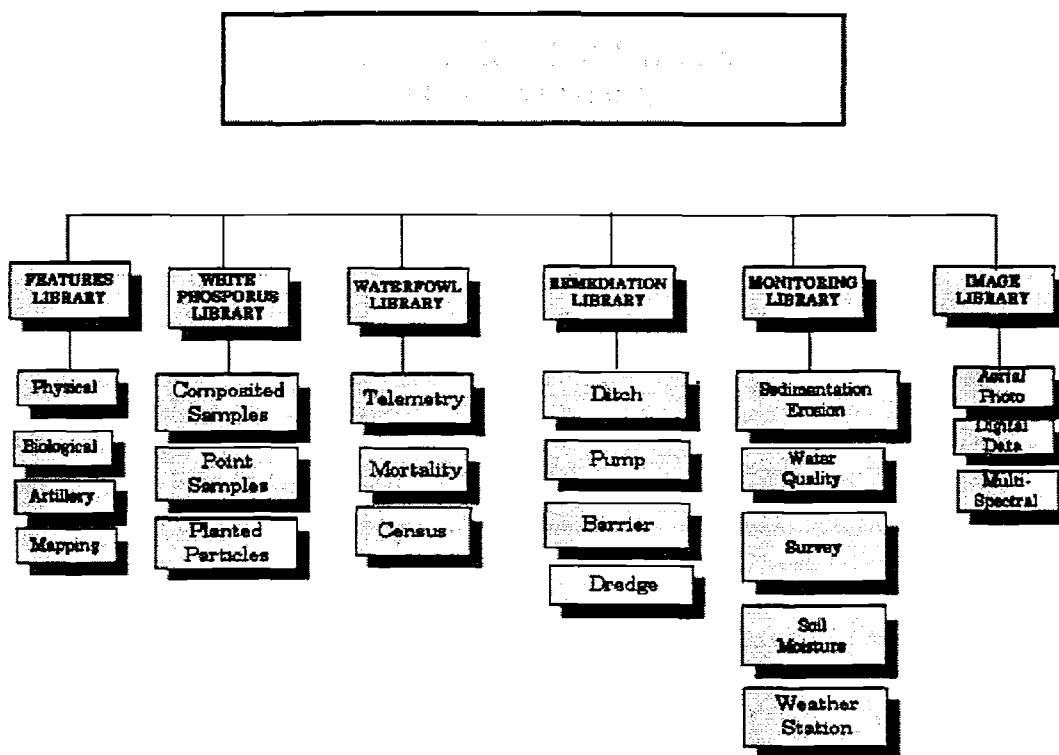

Figure IV-2-1. General contents and structure of the ERF GIS database.

sponsible, and date when treatment began. Other coverages were also produced using both GPS and surveyed locations of features associated with the treatment, such as pumps, pump hoses, generators, ditches, and tidegates.

White phosphorus library

M.E. Walsh has developed techniques for evaluating changes in white phosphorus concentrations and particle attenuation in treated ponds. The methods include point sampling, composite sampling on a grid system and on lines, and the monitoring of size and mass changes in WP particles planted in the sediments of treated areas. Her data have been input yearly into the ERF GIS. White phosphorus coverages currently include the following.

WPSAMP18

This provides the concentration of WP in point sediment grab samples. All point grab samples collected and analyzed since 1990 are included in this coverage, which now contains

about 2860 samples. Attributes for each sample include collector, date, sample treatment, analysis methods, laboratory, etc. In 1998, 83 new point samples were collected and added to this coverage.

COMPs_97f, COMPf_97, COMPs_98, COMPf_98f, Tran1, Pen5

These are polygons where sediment subsamples were collected, composited, and analyzed for white phosphorus in spring 1997, fall 1997, spring 1998, and fall 1998. The spring and fall composites were designed to show if concentrations had changed during the summer drying season. In addition sediment samples from pen5 were composited in 1996 and those from Tran1 were composited in fall 1997. Attributes include date sampled, person, method, number and spacing of subsamples, concentrations in replicates, and mean.

COMPLINES

In 1998, C.M. Collins and M.E. Walsh collected and composited subsamples at equal

intervals along 17 curved or straight lines in treated ponds, mostly in Area A Ponds 258 and 256, which were pumped during the summer of 1998. Attributes include line length, sample interval, number of subsamples, size of composite sample, sampler, sample date, analytical method, and WP concentration in $\mu\text{g/g}$.

PLPARTS

This provides point locations where M.E. Walsh planted manufactured white phosphorus particles of known mass and size in spring 1997 and 1998. These were harvested in the fall, and the change in mass and size of the particles was determined. Attributes include number planted, mass, planter, date of planting, date of harvest, and percent attenuation of each particle harvested, as well as the average percent attenuation.

Monitoring library

M.E. Walsh, C.M. Collins, and M.R. Walsh established dataloggers in treated ponds to monitor sediment moisture and temperature to determine if sediments reached conditions under which white phosphorus particles would sublime. The monitoring took place in 1997 in Bread Truck Pond, which was ditched in 1995, and C Pond, which was pumped during the summer of 1997. In 1998 dataloggers were again installed in these two ponds and in the newly treated (pumped) ponds (290, 256, and 258). The summer graphs of temperature and moisture are accessed in ARCVIEW using the hotlink feature with the sediment monitoring coverage.

Waterfowl library (TELEM98)

This gives daily point locations for over 100 radio-collared mallards, which were trapped during August 1998 and monitored through October 1998 by the National Wildlife Research Center, Ft. Collins, Colorado (Cummings et al., this volume). These data

were used to produce maps for the individual birds, to show capture location, mortality location, and the last 10 observation locations before the mortality signal. We also analyzed the time and distance between the last live observation and the first mortality signal. We can also compare the use of a treated pond by radiotagged waterfowl before (using prior telemetry databases) and after treatment and whether any mortality occurred in the vicinity of a particular pond before and after treatment.

Image library

A library of 37 aerial images of Eagle River Flats (Table IV-2-1) is actively maintained at CRREL, with new images obtained annually (mid-August) to monitor change. Most of the images are aerial photos, but digital multispectral video and Landsat images are also included. Scanning and georeferencing of aerial photos is underway to make them more useful for change assessment in a GIS context. Since a number of frames are required to cover the entire ERF at a scale of 1 in. = 500 ft, individual frames are scanned and georeferenced.

Images of treated ponds before and after remediation can be used to help evaluate the effectiveness and extent of pond drainage by viewing aerial photos of ponds before and after drainage. On color IR aerial photos, the exposed silt bottom of ponds is much lighter than areas with standing water. The photos also show localized pools or wet areas within drained ponds that may require additional ditching. In another section of this report (Racine et al., this volume), we use scanned and georeferenced images to assess changes associated with pond drainage and erosional processes. In 1997 (Racine et al. 1997), we used Digital Multispectral Video images (DMSV) (four bands from visible to infrared) obtained 1 week apart (11 June to 17 June) to evaluate drying of the sediments during a long period without flooding tides.

Table IV-2-1. List of images available for change assessment in ERF.

<i>Year</i>	<i>Date</i>	<i>Type</i>	<i>Scale</i>	<i>Date previous tide</i>	<i>Days high tide</i>	<i>Other comments</i>
1950	8 Aug	Grey scale	1 in. = 1500 ft	?		
1953	27 June	Grey scale	High alt			
1957	12 June	Grey scale				
1960	30 Aug	Grey scale	1:60000	10 Aug	20	
1962	17 May	Grey scale	1:6000	7 May	10	
1967	Unkown	Grey scale				
1972	July	Color infrared				
1972	9 Aug	Grey scale		13 July	27	
1974	7 May	Grey scale	1 in. = 1000 ft	April		
1977	Unkown					
1978	Aug					
1984	12 Aug	CIR	High alt	1 Aug	11	
1984	2 Sept	True color	1 in. = 1000 ft	31 Aug	2	
1986	12 Sept	Landsat TM		7 Sept	5	
1986	5 Oct	True color	1 in. = 1000 ft	5 Oct	0	
1988	4 Aug	Grey scale	1 in. = 3000 ft	3 Aug	1	
1990	24 May	True color	1:21,000	24 May	0	
1991	21 July	CIR	1 in. = 600 ft	15 June	6	A and C georef.
1991	21 July	CASI digital	2.5-m pixel	15 June	6	9 bands
1992	22 May	CIR	1 in. = 500 ft	7 May	15	
1992	2 Aug	CIR	1 in. = 1000 ft	2 Aug	0	
1993	8 July	Grey scale		8 May	60	Ortho photo
1993	8 July	CIR		8 May	60	
1994	30 Aug	CIR	1 in. = 600 ft	11 Aug	19	
1994	30 Aug	CIR		11 Aug	19	Ortho photo
1995	16 Aug	CIR	1 in. = 600 ft	14 Aug	2	Scan/georef.
1995	11 Aug	DMSV*	1.5-m pixels	11 Aug	0	450,550, 650,770
1995	9 Oct	True color	1 in. = 1200 ft	9 Oct	0	
1996	4 Oct	True color	1 in. = 500 ft	30 Sept	5	
1997	11 June	DMSV* georef	1.5-m pixels	8 May	34	550,650, 770,950
1997	17 June	DMSV*georef	1.5-m pixels	8 May	40	Same bands
1997	27 July	True color	1 in. = 500 ft	23 July	4	
1997	24 May	True color	1 in. = 1000 ft	8 May	16	
1997	May	Grey scale	2-m pixels			Ortho photo
1997	14 Aug	Grey scale	1 in. = 2500 ft	22 July	21	
1998	17 Aug	DMSV*	1.5-m pixels	4 Aug	13	450, 550, 650,770
1998	17 Aug	CIR	1 in. = 600 ft	4 Aug	13	Scan/georef.

*Digital MultiSpectral Video