

**UNITED STATES AIR FORCE
ELMENDORF AIR FORCE BASE, ALASKA**

ENVIRONMENTAL RESTORATION PROGRAM

ST407 REMOVAL ACTION REPORT

JANUARY 2002

TABLE OF CONTENTS

<u>SECTION</u>	<u>PAGE</u>
ABBREVIATIONS.....	iii
1.0 INTRODUCTION.....	1-1
1.1 PROJECT BACKGROUND.....	1-1
1.2 SITE BACKGROUND.....	1-2
1.3 REMOVAL SUMMARY.....	1-2
2.0 FIELD ACTIVITIES.....	2-1
2.1 SOIL EXCAVATION.....	2-1
2.2 CONFIRMATION SAMPLE COLLECTION.....	2-2
2.3 EXCAVATION BACKFILLING AND SITE RESTORATION.....	2-4
3.0 ANALYTICAL RESULTS.....	3-1
4.0 CONCLUSIONS.....	4-1
5.0 REFERENCES.....	5-1

TABLES

Table 2-1 Project Schedule.....	2-1
Table 2-2 Confirmation Sample Analytical Methods.....	2-4
Table 3-1 Confirmation Sample Analytical Results, Site ST407.....	3-2

FIGURES

Figure 1-1 ST407 Location Map.....	1-3
Figure 2-1 ST407 Site Map.....	2-3

APPENDICES

Appendix A	SERA Investigation Results
Appendix B	Soil Treatment Confirmation
Appendix C	Backfill Material Specifications, Compaction Test Results
Appendix D	Data Quality Assessment, Analytical Data Package

(intentionally blank)

ABBREVIATIONS

AAC	Alaska Administrative Code
ADEC	Alaska Department of Environmental Conservation
AFB	Air Force Base
ASR	Alaska Soil Recycling
bgs	below ground surface
BTEX	benzene, toluene, ethylbenzene, xylenes
DRO	diesel-range organics
EPA	U.S. Environmental Protection Agency
GRO	gasoline-range organics
mg/kg	milligrams per kilogram
PAHs	polynuclear aromatic hydrocarbons
PID	photoionization detector
POL	petroleum, oil, and lubricant
ppm	parts per million
RRO	residual-range organics
SERA	State-Elmendorf Environmental Restoration Agreement
TERC	Total Environmental Restoration Contract
USAED	U.S. Army Engineer District, Alaska
USAF	U.S. Air Force
UST	underground storage tank

(intentionally blank)

1.0 INTRODUCTION

This report summarizes the removal of petroleum, oil, and lubricants (POL) impacted soil and collection of soil confirmation samples at Site ST407 on Elmendorf Air Force Base (AFB), Alaska, during the summer of 2001. The work was performed in support of the U.S. Air Force (USAF) 3rd Civil Engineering Squadron under the U.S. Army Engineer District, Alaska, (USAED) Total Environmental Restoration Contract (TERC), Contract No. DACA 85-95-D-0018, Task Order No. 12.

1.1 PROJECT BACKGROUND

Site ST407 is included in the State-Elmendorf Environmental Restoration Agreement (SERA) program. This cooperative agreement between the USAF and Alaska Department of Environmental Conservation (ADEC) addresses Elmendorf AFB's solid waste, underground storage tank (UST), and POL spill program areas. The SERA requires that Elmendorf AFB perform necessary assessments, monitoring, remediation, and closure of these applicable sites, as well as new sites identified subsequent to the issuance of the SERA.

Elmendorf AFB sites were investigated in phases under the SERA program. Each phase defines a group of sites that were addressed during a specific time or phase of the ongoing program and does not refer to the different types of investigations or steps in a specific process. In some cases, the succeeding SERA investigations were performed to fill data gaps identified in previous SERA investigations. Site ST407 was investigated under SERA Phase IV in 1996. A summary of the SERA investigation results is provided in Section 1.2, and complete results are in the SERA Phase IV ST407 Release Investigation Report (USAF 1997).

The SERA investigation report and site history were reviewed in spring 2001 to evaluate site conditions and develop corrective actions for the site if required. Site ST407 was recommended for excavation of shallow contamination and monitoring of deep contamination. Shallow contamination is defined as contamination between 0 to 15 feet below ground surface (bgs). Additional information on the evaluation and recommendation can be found in the Corrective Action Plan, Eleven SERA IV Sites, Final, Revision 1 (USAF 2001).

1.2 SITE BACKGROUND

ST407 is the site of three former USTs near Building 17504 (former Building #43-575) on Elmendorf AFB (Figure 1-1). The three USTs included a 500-gallon used synthetic hydraulic oil UST (AFID 575); a 1,000-gallon used synthetic turbine oil UST (AFID 576); and a 2,000-gallon JP-4 UST (AFID 578). The USTs were removed in August 1994 (USAF 1995). Soil sampling conducted during the UST removal revealed gasoline-range organics (GRO), diesel-range organics (DRO), and benzene, toluene, ethylbenzene, and total xylenes (BTEX) at maximum levels of 420 milligrams per kilogram (mg/kg); 9,000 mg/kg; and 22.7 mg/kg, respectively (USAF 1995). Site soil is sandy gravel and depth to groundwater is 42 feet bgs.

The SERA investigation was conducted in 1996, during which six borings were drilled at Site ST407. Two soil samples were collected from each boring and analyzed for GRO, DRO, residual-range organics (RRO), and BTEX. One sample was collected from just above the water table in the smear zone and one was collected from the interval with the highest field screening result. The maximum levels of GRO were 257 mg/kg at 16 feet bgs and 151 mg/kg at 41 feet bgs. The maximum levels of DRO were 2,600 mg/kg at 16 feet bgs and 1,800 mg/kg at 41 feet bgs. RRO was detected at a maximum of 450 mg/kg at 16 feet bgs. Benzene was detected in only one sample at 0.15 mg/kg at 16 feet bgs. All maximum hits described above were in samples collected from the soil boring at Monitoring Well 407WL01 at the location of the former USTs. Only one other downgradient boring, at Piezometer 407PZ03, exhibited significant contaminant concentrations in the smear zone only (USAF 1997). Summary data from the SERA investigation is provided in Appendix A for reference.

1.3 REMOVAL SUMMARY

The removal effort included excavation, transportation, and thermal treatment of soil; field screening; confirmation sampling; and site restoration.

A total of 73.5 tons of soil were excavated and transported to Alaska Soil Recycling (ASR) in Anchorage, Alaska, for thermal treatment. A photoionization detector (PID) was used to evaluate the horizontal and vertical extent of the soil contamination. Three confirmation samples



Elmendorf AFB
Fort Richardson

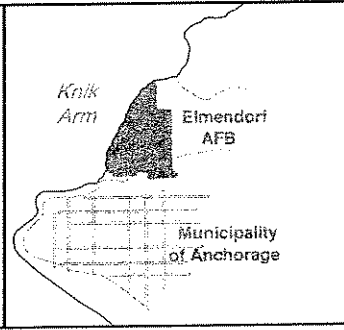
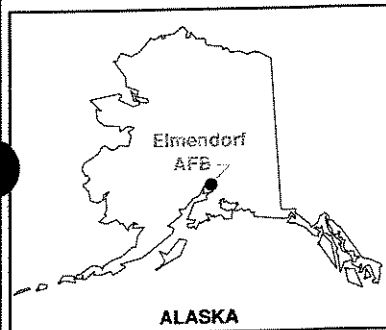
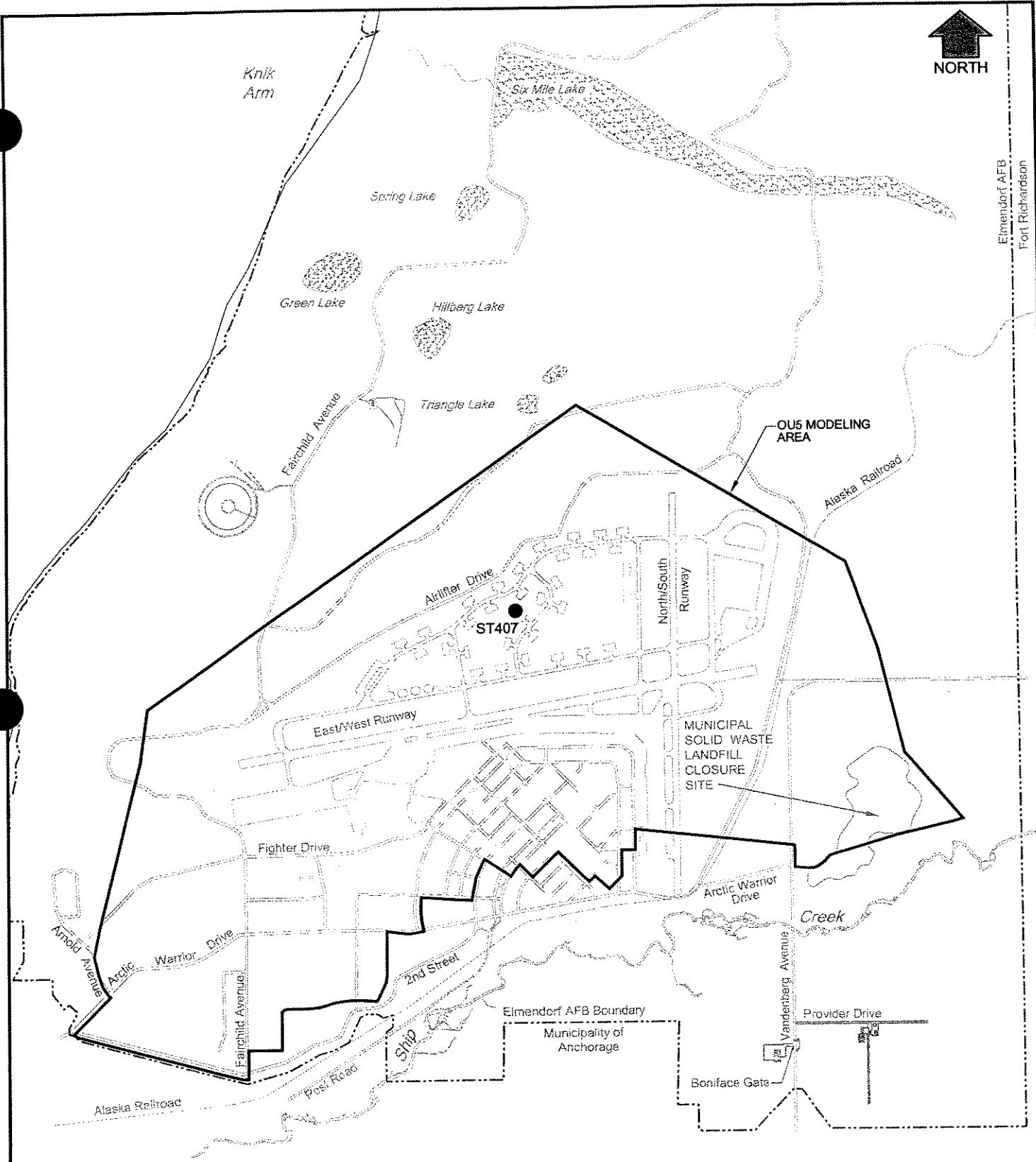

ST407 LOCATION MAP

ELMENDORF AFB, ALASKA

PROJECT MANAGER: M. Pogany	FILE NAME: Report Sites	DATE: Jan. 28, 02
JE	LAYOUT TAB: ST407 Loc	FIGURE NO.: 1-1
	FILE LOCATION: Elmendorf \05M31201 \ Report Sites	

and one duplicate were collected from the floor of the excavation. The site was backfilled with clean fill material. A more detailed explanation of the work performed is provided in Section 2.0.

2.0 FIELD ACTIVITIES

Field activities were conducted at the site as described below. The project schedule is presented in Table 2-1.

**Table 2-1
Project Schedule**

TASK	DATES
Removal of concrete surfacing	10 July 2001
Field screening and soil excavation and transportation for thermal treatment	10 – 11 July 2001
Confirmation soil sample collection for laboratory analysis	11 July 2001
Excavation backfilling and site restoration. Concrete surfacing could not be replaced at this site due to security requirements in this area of the base.	3 – 4 August 2001

2.1 SOIL EXCAVATION

Prior to initiating activity at the site, the USAF obtained approval from ADEC to transport the POL-contaminated soil to ASR for thermal treatment, and a "Base Civil Engineer Work Clearance Request" form (Utility Clearance) was completed and approved for work at the site.

A 12-inch thick reinforced concrete apron covers the ST407 area. A portion of the concrete was removed during the UST removal and was replaced by 3-inch thick non-reinforced concrete. The 3-inch thick concrete was removed to excavate soil during this removal effort.

Soil excavation was initiated at SERA monitoring well location 407WL01, where the highest contamination levels were detected during the SERA investigation, and continued based on visible staining and PID field screening. As soil was removed from the excavation, direct PID readings were obtained by placing the tip of the PID probe adjacent to the freshly exposed soil (typically in the excavator bucket) to obtain a gross indication of volatile fuel contamination in the soil. Soil was also field screened in accordance with the UST Procedures Manual (ADEC 1999), Section 4.4.2 for headspace PID readings. These readings were obtained by partially filling resealable freezer bags with soil and allowing the vapors to volatilize in the headspace.

The samples were heated by placing the freezer bags in a hot water bath for approximately 5 to 10 minutes. The tip of the PID was then placed inside the bags to collect a headspace reading.

Direct PID readings were 0 parts per million (ppm) up to 11 feet bgs. Soil near the surface with no visible staining and PID readings of 0 ppm was stockpiled onsite as clean material to be used as backfill. Approximately 100 cubic yards were stockpiled for use as backfill. All other excavated material was transported to ASR for thermal treatment. Direct PID readings increased to 57 ppm, and a fuel odor and gray-silver staining was observed at 14 feet bgs. At 16 feet bgs direct PID readings increased to 97 ppm in the excavation. On the east sidewall, visible staining was observed starting at 14 feet bgs. On the west sidewall at 16 feet bgs the direct PID reading was 10 ppm and no fuel odor or visible staining was observed.

The 12-inch thick reinforced concrete apron limited soil excavation on the east side. The maximum amount of soil was removed without disturbing the concrete apron. Sample EL-A200703 was collected from the east sidewall near the base of the excavation to represent possible contamination remaining at the site. Soil removal resulted in an excavation measuring approximately 27 feet long, 25 feet wide, and 18 feet deep. At the base, the excavation measured approximately 12 feet long and 12 feet wide due to sloping of the excavation sidewalls. A total of 73.5 tons of soil were excavated and transported to ASR for thermal treatment. All soil from the 2001 SERA removal actions was consolidated at ASR. Treatment of all soil was completed in September 2001 and confirmation of treatment is provided in Appendix B. Treated soil was returned to the Elmendorf AFB Municipal Solid Waste Landfill Closure Site in November 2001.

2.2 CONFIRMATION SAMPLE COLLECTION

Upon completion of the excavation, three confirmation samples and one duplicate sample were collected from the excavation. ADEC Underground Storage Tanks regulation 18 AAC 78 (ADEC 2000b) was used to determine the number of samples. 18 AAC 78.090 requires that at least two samples be collected for the first 250 square feet of excavated pit area and one sample collected for each additional 250 square feet of excavated pit area. The excavated pit area at ST407 was approximately 675 square feet. Although four samples were required by 18 AAC 78, the frequency was reduced based on the assumption that contamination remained at the site based on field screening and visual observation. Sample locations are identified in Figure 2-1.

BUILDING 17504

NOTES :

ALL UNITS IN mg/kg
CLEANUP CRITERIA EXCEEDANCES IN BOLD
DEPTH TO GROUNDWATER = 42' bgs

- bgs = BELOW GROUND SURFACE
- J = RESULT IS ESTIMATED
- GRO = GASOLINE-RANGE ORGANICS
- DRO = DIESEL-RANGE ORGANICS
- RRO = RESIDUAL-RANGE ORGANICS
- B = BENZENE
- E = ETHYLBENZENE
- T = TOLUENE
- X = TOTAL XYLENES
- () = LABORATORY REPORTING LIMIT
- ND = NOT DETECTED

0 5 10 20

SCALE IN FEET



LEGEND

- X SOIL SAMPLE LOCATION
- ⊕ SERA MONITORING WELL LOCATION
- ⊕ SERA PIEZOMETER WELL LOCATION

EL-A200704 (16' bgs)

GRO = 1.53 J
 DRO = ND (10.7)
 RRO = 7.47
 B = 0.01
 E = 0.0134
 T = 0.102
 X = 0.0901

FORMER LOCATION
OF SERA MONITORING
WELL 407WL01

EL-A200701 (18' bgs)	EL-A200702 (18' bgs) (DUPLICATE)
GRO = 1.94 J	GRO = 1.45 J
DRO = 150	DRO = 29.8
RRO = 488	RRO = 89.6
B = ND (0.0158)	B = ND (0.0164)
E = ND (0.0304)	E = 0.0101
T = 0.0566	T = 0.0659
X = 0.0901	X = 0.0561
ARSENIC = 5.39	ARSENIC = 4.55
CHROMIUM = 30	CHROMIUM = 29.4

EL-A200703 (16' bgs)

GRO = 43.8
DRO = 972
 RRO = 251
 B = ND (0.0176)
 E = 0.0159 J
 T = 0.0956
 X = 0.1246

⊕407-PZ-01

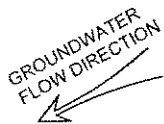

27'

25'

LIMITS OF
EXCAVATION

12" REINFORCED
CONCRETE APRON

407-PZ-03 ⊕

⊕407-PZ-04

ST407 SITE MAP

ELMENDORF AFB, ALASKA

PROJECT MANAGER: M. Pogany	FILE NAME: Report Sites	DATE: Jan. 31, 02
DRAWN BY: JE	LAYOUT TAB: ST407	FIGURE NO.: 2-1
FILE LOCATION: Elmendorf \ 05M31201 \ Report Sites		

The samples were analyzed for the compounds and associated analytical methods listed in Table 2-2. Analytical results are presented in Section 3.0.

**Table 2-2
Confirmation Sample Analytical Methods**

Compound	Method	Frequency
GRO	AK101	100% of samples
DRO	AK102	100% of samples
RRO	AK103	100% of samples
BTEX	SW8260B	100% of samples
PAHs	SW8270CSIM	One Sample Location (EL-A200701 and duplicate EL-A200702)
Metals (As, Cd, Cr, Pb)	SW6020	One Sample Location (EL-A200701 and duplicate EL-A200702)

Notes:
 BTEX = benzene, toluene, ethylbenzene, xylenes
 DRO = diesel-range organics
 GRO = gasoline-range organics
 PAHs = polynuclear aromatic hydrocarbons
 RRO = residual-range organics

Sample analyses were selected based on the UST Procedures Manual (ADEC 1999), Table 2 for known used oil, SERA investigation analytical results, and ADEC regulations. Polynuclear aromatic hydrocarbons (PAH) and metals sample frequency was reduced since clean closure was not expected due to excavation limitations and contamination detected in the smear zone during the SERA investigation. Only the listed metals were analyzed since the contaminant sources were used hydraulic oil and used turbine oil. A summary of SERA analytical results is provided in Appendix A.

2.3 EXCAVATION BACKFILLING AND SITE RESTORATION

After receipt of sample results, the excavation was backfilled and the area regraded. Backfill material was transported from a fill source location on Elmendorf AFB; sieve analysis and modified proctor results for the material are provided in Appendix C. The material was placed in 6-inch lifts and compacted with a remotely controlled vibratory compactor. Four compaction tests were conducted and USAF compaction requirements were met (USAF 1999). Compaction testing data is provided in Appendix C. This site could not be accessed in October 2001 due to

increased security requirements in this area; therefore, concrete surfacing could not be replaced. Replacement of concrete surfacing should be re-evaluated in spring 2002.

3.0 ANALYTICAL RESULTS

The confirmation soil samples collected from the excavation were submitted to CT&E Environmental Services, Inc., for analysis. A trip blank was included in the cooler and analyzed for GRO and BTEX. Quality control samples were collected at a frequency of 10 percent of all 2001 SERA site removal action samples. A data quality assessment is included as Appendix D.

The analytical results for the confirmation samples and trip blank are presented in Table 3-1, and confirmation sample results are presented in Figure 2-1. Analytical results were compared to 18 AAC 75 (ADEC 2000a) Method Two regulatory criteria (18 AAC 75.341, Method Two, Tables B-1 and B-2, Under 40 Inch Zone, most stringent criteria). DRO, arsenic, and chromium exceeded the regulatory criteria. Sample EL-A200703 collected from the east sidewall near the floor of the excavation had a DRO concentration of 972 mg/kg, exceeding the Method Two cleanup criteria of 250 mg/kg. Sample EL-A200701 collected at the center of the excavation contained arsenic and chromium at 5.39 mg/kg and 30 mg/kg, respectively. The regulatory cleanup levels of arsenic and chromium are 2 mg/kg and 26 mg/kg, respectively. Although the results exceeded the regulatory criteria, they are within the range of background concentrations in soil at Elmendorf AFB. Background soil analytical data were reported in the Basewide Background Sampling Report (USAF 1993) and have been approved by the U.S. Environmental Protection Agency (EPA) and ADEC. The mean reported background level for subsurface soil for arsenic and chromium is 5.46 mg/kg and 31.60 mg/kg, respectively. The analytical data are included in Appendix D.

Table 3-1
Confirmation Sample Analytical Results
Site ST407

				Location Sample ID Depth BGS		Center of Excavation EL-A200701 18 feet		Duplicate of EL-A200701 EL-A200702 18 feet		Center of Excavation, East EL-A200703 16 feet		North End of Excavation EL-A200704 16 feet		Trip Blank EL-A200705 NA	
Analyte	Method	Units	Cleanup Criteria ¹												
Gasoline Range Organics	AK101	mg/kg	300	1.94	[4.11] J	1.45	[3.65] J	43.8	[3.38]	1.53	[3.18] J	ND	[2.6]		
Diesel Range Organics	AK102	mg/kg	250	150	[10.6]	29.8	[10.4]	972	[54.2]	ND	[10.7]	-	-		
Residual Range Organics	AK102	mg/kg	10000	488	[21.1]	89.6	[20.9]	251	[108]	7.47	[21.4] J	-	-		
Acenaphthene	PAHSIM	ug/kg	210000	ND	[4.85]	ND	[6.19]	-	-	-	-	-	-		
Acenaphthylene	PAHSIM	ug/kg		ND	[4.85]	ND	[6.19]	-	-	-	-	-	-		
Anthracene	PAHSIM	ug/kg	4300000	ND	[4.85]	ND	[6.19]	-	-	-	-	-	-		
Benzo(a)anthracene	PAHSIM	ug/kg	6000	ND	[4.85]	ND	[6.19]	-	-	-	-	-	-		
Benzo(a)pyrene	PAHSIM	ug/kg	1000	ND	[4.85]	ND	[6.19]	-	-	-	-	-	-		
Benzo(b)fluoranthene	PAHSIM	ug/kg	11000	ND	[4.85]	ND	[6.19]	-	-	-	-	-	-		
Benzo(g,h,i)perylene	PAHSIM	ug/kg		ND	[4.85]	ND	[6.19]	-	-	-	-	-	-		
Benzo(k)fluoranthene	PAHSIM	ug/kg	110000	ND	[4.85]	ND	[6.19]	-	-	-	-	-	-		
Chrysene	PAHSIM	ug/kg	620000	ND	[4.85]	ND	[6.19]	-	-	-	-	-	-		
Dibenzo(a,h)anthracene	PAHSIM	ug/kg	1000	ND	[4.85]	ND	[6.19]	-	-	-	-	-	-		
Fluoranthene	PAHSIM	ug/kg		ND	[4.85]	ND	[6.19]	-	-	-	-	-	-		
Fluorene	PAHSIM	ug/kg	270000	ND	[4.85]	ND	[6.19]	-	-	-	-	-	-		
Indeno(1,2,3-cd)pyrene	PAHSIM	ug/kg	11000	ND	[4.85]	ND	[6.19]	-	-	-	-	-	-		
Naphthalene	PAHSIM	ug/kg	43000	ND	[4.85]	ND	[6.19]	-	-	-	-	-	-		
Phenanthrene	PAHSIM	ug/kg		1.6	[4.85] J	ND	[6.19]	-	-	-	-	-	-		
Pyrene	PAHSIM	ug/kg	1500000	ND	[4.85]	ND	[6.19]	-	-	-	-	-	-		
Arsenic	SW6020	mg/kg	2	5.30	[1]	4.55	[0.948]	-	-	-	-	-	-		
Cadmium	SW6020	mg/kg	5	ND	[0.2]	ND	[0.19]	-	-	-	-	-	-		
Chromium	SW6020	mg/kg	26	30	[1]	29.3	[0.948]	-	-	-	-	-	-		
Lead	SW6020	mg/kg	400	6.12	[0.2]	7.14	[0.19]	-	-	-	-	-	-		
Benzene	SW8260B	mg/kg	0.02	ND	[0.0158]	ND	[0.0164]	ND	[0.0176]	0.01	[0.0134] J	ND	[0.0135]		
Ethylbenzene	SW8260B	mg/kg	5.5	ND	[0.0304]	0.0101	[0.0315] J	0.0159	[0.0338] J	0.0134	[0.0258] J	ND	[0.026]		
Toluene	SW8260B	mg/kg	5.4	0.0566	[0.0304]	0.0659	[0.0315]	0.0956	[0.0338]	0.102	[0.0258]	ND	[0.026]		
Total Xylenes	SW8260B	mg/kg	78	0.0486	[0.0304]	0.0561	[0.0315]	0.1246	[0.0338]	0.0901	[0.0258]	ND	[0.026]		

Notes:

¹ ADEC regulatory criteria based on 18 AAC 75 Method Two (18 AAC 75.341, Method Two, Tables B1 and B2, Under 40-inch Zone, Most Stringent Criteria).

Highlighted values exceed 18 AAC 75 Method Two Cleanup Criteria

BGS = below ground surface

J = Result is below laboratory reporting limit.

mg/kg = milligrams per kilogram

ND = Analyte not detected

ug/kg = micrograms per kilogram

[] = laboratory reporting limit

- = Not Analyzed

4.0 CONCLUSIONS

The objective of the removal action at Site ST407 was to reduce risk by excavating soil with contaminant concentrations above regulatory criteria, as outlined in 18 AAC 75 (ADEC 2000a). Sample results from this removal action confirm that the site meets 18 AAC 75 Method Two cleanup criteria for GRO, RRO, and BTEX. The site also meets Method Two cleanup criteria for PAHs at sample location EL-A200701. However, this PAH sample was not collected from the location of highest contamination detected during this investigation. Arsenic and chromium exceed the regulatory criteria but are within the range of expected background concentrations. DRO does exceed the 18 AAC 75 Method Two cleanup criteria.

Contaminated soil was excavated and removed to the maximum extent possible to 16 to 18 feet bgs. However, DRO contamination remains at 16 feet bgs, and contamination was detected at the smear zone during the SERA investigation.

(intentionally blank)



5.0 REFERENCES

- Alaska Department of Environmental Conservation (ADEC). 2000a (October). *Oil and Hazardous Substances Control Regulations*. 18 AAC 75.
- ADEC. 2000b (August). *Underground Storage Tanks*. 18 AAC 78.
- ADEC. 1999 (December). *Underground Storage Tanks Procedures Manual*.
- U.S. Air Force (USAF). 2001 (July). *Corrective Action Plan Eleven SERA IV Sites (Final, Revision 1)*. Environmental Restoration Program. Elmendorf Air Force Base, Alaska.
- USAF. 1999 (July). *FXSB 99-2000 M/R Base Pavements Specifications*. 3rd Contracting Squadron. Elmendorf AFB, Alaska.
- USAF. 1997 (March). *Release Investigation Report, SERA Phase IV ST407 (Draft Final)*. Environmental Compliance Program. Elmendorf AFB, Alaska.
- USAF. 1995 (February). *Underground Storage Tank Closure Assessment, Delivery Order 0006, Buildings 43-574 and 43-575 (Draft)*. Elmendorf AFB, Alaska. Prepared by Shannon and Wilson Inc.
- USAF. 1993 (January). *Elmendorf AFB, Alaska Basewide Background Sampling Report*. Elmendorf AFB, Alaska. Prepared by CH2M Hill.
- U.S. Army Corps of Engineers (USACE). 1997 (October). *Environmental Quality – Chemical Quality Assurance for Hazardous, Toxic, and Radioactive Waste (HTRW) Projects*. EM200-1-6.
- U.S. Environmental Protection Agency (EPA). 1999 (October). *USEPA Contract Laboratory Program, National Functional Guidelines for Organic Data Review*. OSWER 9240.1-05A-P. Washington, D.C.

(intentionally blank)



APPENDIX A
SERA Investigation Results

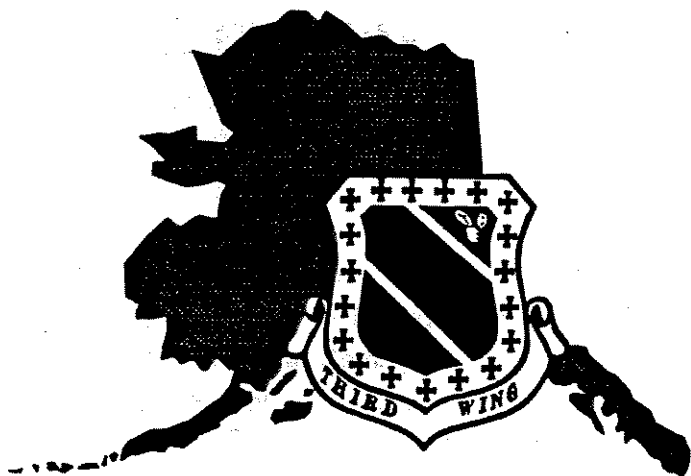

**UNITED STATES AIR FORCE
ELMENDORF AIR FORCE BASE, ALASKA**

ENVIRONMENTAL COMPLIANCE PROGRAM

**AFIDS 575, 576, AND 578
SERA PHASE IV ST407
RELEASE INVESTIGATION REPORT**

DRAFT FINAL

MARCH 1997

CONTENTS

1.0 INTRODUCTION	1-1
1.1 ST407 Site Background	1-1
1.2 Regional Setting	1-4
1.3 Report Outline	1-6
2.0 METHODS	2-1
2.1 Initial Activities	2-1
2.2 Borings	2-2
2.3 Soil Sampling	2-2
2.4 Field Quality Control Samples	2-5
2.5 Sampling Control	2-6
2.6 Decontamination	2-7
2.7 Disposition of Investigation-Derived Waste	2-7
2.8 Survey	2-8
2.9 Soil Gas Survey	2-8
2.10 Air Permeability	2-8
2.11 Data Analysis	2-9
2.11.1 Petroleum Hydrocarbon Data	2-9
2.11.2 Inorganic Data	2-9
2.11.3 Soil Gas Concentrations	2-10
2.11.4 Soil Air Permeability and Anisotropy	2-10
3.0 RESULTS	3-1
3.1 Release Investigation Results	3-1
3.2 Bioventing Treatability Study	3-4
4.0 CONCLUSIONS	4-1
5.0 REFERENCES	4-2

APPENDICES

LIST OF TABLES

2-1	Soil Sample Analytical Summary for ST407	2-5
2-2	Matrix Score Cleanup Levels	2-9
3-1	ST407 Soil Contaminant Results	3-3
3-2	ST407 Soil Nutrient, TOC, and pH Results	3-3
3-3	ST407 Soil Gas Survey Results	3-4

LIST OF FIGURES

1-1	Elmendorf AFB Location Map	1-2
1-2	Composite Site Location Map	1-3
1-3	Generalized Groundwater Flow Direction	1-5
2-1	Typical Bioventing Well Completion	2-3
2-2	Typical Piezometer Completion	2-4
3-1	ST407 Site Map Showing Soil Sample Results	3-2

3.0 RESULTS

3.1 Release Investigation Results

The ST407 release investigation was conducted in June 1996. The surface above the former tank locations at ST407 was unpaved at the time of the release investigation, and was surrounded by concrete and covered by gravel. Three corrugated, perforated drain pipes are installed in the site area. No significant surface stains were observed. The former USTs location was determined by the gravel area and the UST removal coordinates.

Six borings were completed at ST407, including one bioventing air injection well (407WL01), four soil gas monitoring arrays (407PZ01 through 407PZ04), and one boring that was grouted following installation (407BH01). Boring locations and analytical results are displayed in Figure 3-1. Boring details are provided on boring logs in Appendix B. Groundwater was encountered at approximately 42 feet bgs. Site soils consist of sand and gravel typical to the Elmendorf outwash plain. Soil samples contained elevated ATH/PID readings and smelled of petroleum hydrocarbons from all samples collected from boring 407WL01. For this reason analytical results were compared to ADEC Level A cleanup standards. Field screening results for petroleum hydrocarbons were negative for all other borings.

Soil petroleum hydrocarbon analytical results are summarized on Table 3-1 and Figure 3-1 and fully reported in Appendix C. Soil contamination above ADEC Level A cleanup standards was detected in 3 of the 12 normal soil samples collected at ST407, with maximum concentrations of 450 mg/Kg RRO, 2600 mg/Kg DRO, 257 mg/Kg GRO, 0.15 mg/Kg benzene, and 3.55 mg/Kg total BTEX. Chromatograms were not conclusive, but were indicative of weathered middle distillates. Other soil physical and chemical results are presented on Table 3-2.

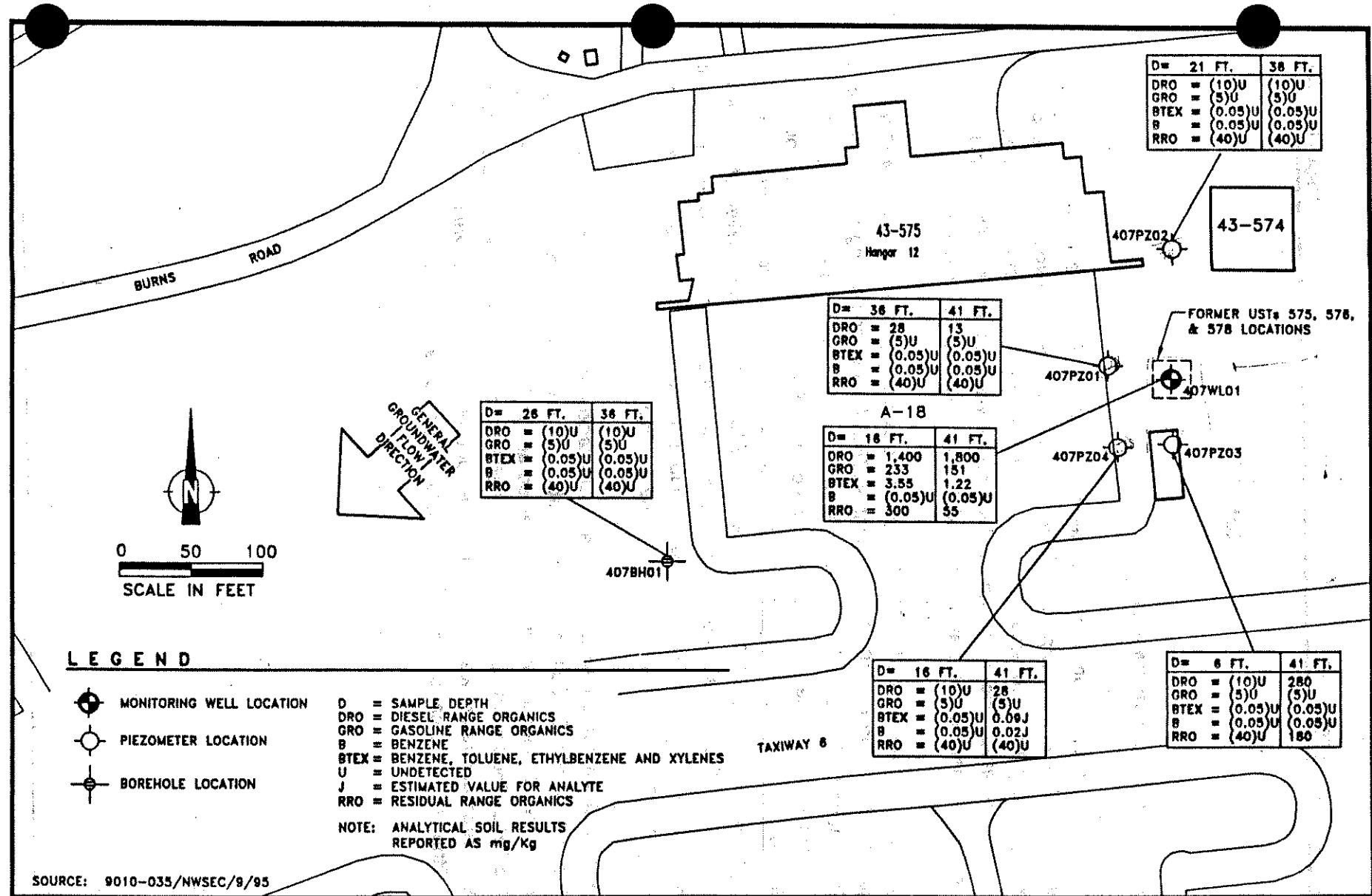

D= 21 FT.	38 FT.
DRO = (10)U	(10)U
GRO = (5)U	(5)U
BTEX = (0.05)U	(0.05)U
B = (0.05)U	(0.05)U
RRO = (40)U	(40)U

D= 36 FT.	41 FT.
DRO = 28	13
GRO = (5)U	(5)U
BTEX = (0.05)U	(0.05)U
B = (0.05)U	(0.05)U
RRO = (40)U	(40)U

D= 26 FT.	36 FT.
DRO = (10)U	(10)U
GRO = (5)U	(5)U
BTEX = (0.05)U	(0.05)U
B = (0.05)U	(0.05)U
RRO = (40)U	(40)U

D= 16 FT.	41 FT.
DRO = 1,400	1,800
GRO = 233	151
BTEX = 3.55	1.22
B = (0.05)U	(0.05)U
RRO = 300	55

D= 16 FT.	41 FT.
DRO = (10)U	28
GRO = (5)U	(5)U
BTEX = (0.05)U	0.09J
B = (0.05)U	0.02J
RRO = (40)U	(40)U

D= 6 FT.	41 FT.
DRO = (10)U	280
GRO = (5)U	(5)U
BTEX = (0.05)U	(0.05)U
B = (0.05)U	(0.05)U
RRO = (40)U	180

DRAWING: ST407_1
 C/SC: 1:100
 DATE: 2/27/97

DRAWN: SSR
 DISK: Z 9/96
 CHECK: P.R.

FIGURE 3-1
ST407
SITE MAP SHOWING
SOIL SAMPLE RESULTS

3RD SPTG/CEVC
ELMENDORF AFB, ALASKA
PROJECT 9000-068/080

Table 3-1. ST407 Soil Contaminant Results.*

Sample ID	Benzene EPA 8020a	BTEX EPA 8020a	GRO AK101.0	DRO AK102.0	RRO AK103.0
407BH01SO26.0N	(0.05) U	(0.05) U	(5) U	(10) U	(40) U
407BH01SO26.0N DUP	(0.05) U	(0.05) U	(5) U	(10) U	(40) U
407BH01SO36.0N	(0.05) U	(0.05) U	(5) U	(10) U	(40) U
407PZ01SO36.0N	(0.05) U	(0.05) U	(5) U	28	(40) U
407PZ01SO41.0N	(0.05) U	(0.05) U	(5) U	13	(40) U
407PZ02SO21.0N	(0.05) U	(0.05) U	(5) U	(10) U	(40) U
407PZ02SO36.0N	(0.05) U	(0.05) U	(5) U	(10) U	(40) U
407PZ03SO6.0N	(0.05) U	(0.05) U	(5) U	(10) U	(40) U
407PZ03SO41.0N	(0.05) U	(0.05) U	(5) U	280 B	180
407PZ04SO16.0N	(0.05) U	(0.05) U	(5) U	(10) U	(40) U
407PZ04SO41.0N	0.02 J	0.09 (J)	(5) U	28	(40) U
407WL01SO16.0N	(0.05) U	3.55	233 F	1400 C	300
407WL01SO16.0N DUP	0.15	3.26	257 F	2600 F	450
407WL01SO41.0N	(0.05) U	1.22	151 F	1800 C	55

* All results in mg/Kg.
 DUP = Duplicate sample.
 J = Estimated.
 U = Not detected (detection limit).

Table 3-2. ST407 Soil Nutrient, TOC, and pH Results.*

Sample ID	Nitrate-Nitrite 353.2	TKN 351.3	Ammonium 350.3	Phosphate 365.3	TOC D4129	pH 150.1
407WL01SO16.0N	(0.4) U	269	(0.5) U	(20) U	0.11	7.7
407WL01SO41.0N	(0.4) U	94.8	(0.5) U	(20) U	0.09	8.6
407WL01SO41.0N DUP	(0.4) U	116	(0.5) U	(20) U	0.07	8.7

* All units mg/Kg except pH.
 U = Not detected (detection limit).
 TKN = Total Kjeldahl nitrate.
 TOC = Total organic carbon.

3.2 Bioventing Treatability Study

Soil gas samples were collected and analyzed from all sampling locations at ST407. The results are presented in Table 3-3. Oxygen concentrations were above 10 percent in sampling locations except for 407WL01 and 24 feet bgs in 407PZ02. Elevated carbon dioxide concentrations were detected at all sampling locations except for 36 feet bgs in 402PZ01. VOC concentrations were near baseline concentrations except for 407WL01, which contained 62.6 ppm VOCs.

Air permeability of $2.6 \times 10^{-5} \text{ cm}^2$ and a horizontal to vertical anisotropy ratio of 8 were modelled for ST407 based on air injection into 407WL01 at approximately 100 cfm. At an injection rate of 100 cfm, a radial treatment zone of approximately 40 feet will receive 0.3 pore volume exchanges per day using permeable surface cover parameters.

Table 3-3. ST407 Soil Gas Survey Results.

Location	Depth (ft)	O ₂ (%)	CO ₂ (%)	VOC (ppm)	Temperature (°C)	Pressure (Inches H ₂ O)
407WL01	30-40	10	>5	62.6		2.9
407PZ01	12	15	4.6	1.0	11.5	0.03
	24	14	4.8	1.4	9	0.05
	36	21	0	0.8	7	0.10
407PZ02	12	11	>5	6.2		0.05
	24	8	>5	7.2		0.09
	36	15	>5	5.2		0.12
407PZ03	12	13.5	3.8	2.8		0.02
	24	14.5	3.2	3.4		0.04
	36	14.0	4.0	1.0		0.05
407PZ04	12	14.0	4.2	0.8		0.04
	24	13.5	4.4	2.4		0.05
	36	13.5	4.7	0.4		0.09
Flowrate = 103 cfm						

4.0 CONCLUSIONS

Site disposition recommendations for AFIDs 575, 576, and 578 at ST407 will be submitted under separate cover pending the completion of risk assessment work on the affected areas. The ADEC Oil and Hazardous Material Incident Report, Preliminary Risk Evaluation, and Release Investigation Summary Form are provided in Appendix D.

APPENDIX B
Soil Treatment Confirmation

ASR

ALASKA SOIL RECYCLING

A Division of Anchorage Sand & Gravel Co. Inc.
1040 O'Malley Road • Anchorage, Alaska 99515
Phone (907) 349-3333 • FAX (907) 344-2844

October 13, 2001

Jacobs Engineering
4300 B Street, Suite 600
Anchorage, Alaska 99533-5922

Attn: Ms. Mandy Pogany

Re: Soil Disposal From EAFB SERA Projects

Dear Ms. Pogany:

On July 5, 7, 9, 11,-14, 17-19, 23, 27-28, 2001 and August 6-10, 17, 20, 2001 and September 6-7, 2001 Alaska Soil Recycling (ASR) received 2,121.71 tons of petroleum impacted soil from the above referenced site. On July 24, 2001, August 18, 2001, August 24, 2001 and September 9, 2001 thermal treatment of this soil was completed at ASR's Spar Avenue facility in Anchorage, Alaska. Post remedial analysis reveals that this soil meets the Alaska Department of Environmental Conservation's most restrictive level (Level A). Attached is a copy of the analysis summary and laboratory results.

This soil will be recycled for use in the construction industry.

Please contact me with any questions.

Sincerely,

ALASKA SOIL RECYCLING

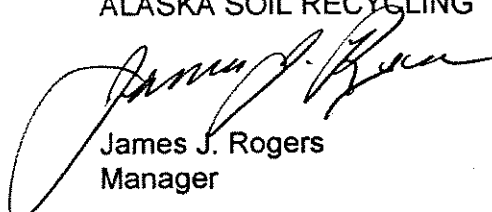

James J. Rogers
Manager

JJR:rj

Attachments

Oil Spill Consultants, Inc.

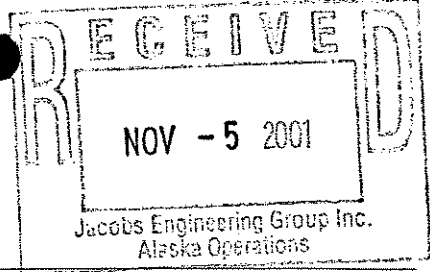

The Environmental Cleanup Company

August 2, 2001

Mr. James J. Rogers
 Environmental Manager
 Alaska Soil Recycling
 1040 O'Malley Road
 Anchorage, Alaska 99515

Subject: Laboratory Results for Third Party Sampling - Account No. 2506

Dear Mr. Rogers:

The results for our July 25, 2001 sampling for Account No. 2506 are attached. These results are summarized as follows:

Sample ID Number	GRO (mg/kg)	Benzene (mg/kg)	Toluene (mg/kg)	Ethylbenzene (mg/kg)	Xylene (mg/kg)	DRO (mg/kg)	RRO (mg/kg)
2001-ASR-2506-242-SL	U	U	0.049	U	U	20.4	48.4
2001-ASR-2506-243-SL	U	U	0.050	U	U	18.9	38.2
2001-ASR-2506-244-SL	U	U	0.041	U	U	17.0	36.7
2001-ASR-2506-245-SL	U	U	0.036	U	U	12.8	32.8
2001-ASR-2506-246-SL	U	U	0.046	U	U	14.2	35.7
2001-ASR-2506-247-SL	U	U	U	U	U	U	U
2001-ASR-2506-248-SL	U	U	U	U	U	U	U
2001-ASR-2506-249-SLD	U	U	U	U	U	U	24.1
ADEC Level "A" Cleanup Criteria	50	-	-	-	-	100	2,000
ADEC Method Two Cleanup Criteria	-	0.02	5.5	5.4	78	-	-

Note: 1. U means undetected. 2. - Means not applicable.

Please be advised that Account No. 2506 meets ADEC Level "A" Cleanup Criteria for GRO, DRO DRO and RRO under Method One in 18 AAC 75.341. This account also meets ADEC Method Two cleanup levels for benzene, toluene, ethylbenzene and xylene (BTEX) in 18 AAC 75.341.

Samples No. 2001-ASR-2506-248-SL and 2001-ASR-2506-249-SLD are duplicates. All samples were collected following ADEC guidelines.

Sincerely,

Randy Easley
 President

Attachments



Oil Spill Consultants, Inc.

The Environmental Cleanup Company

September 11, 2001

Mr. James J. Rogers
 Environmental Manager
 Alaska Soil Recycling
 1040 O'Malley Road
 Anchorage, Alaska 99515

Subject: Laboratory Results for Third Party Sampling - Account No. 2506

Dear Mr. Rogers:

The results for our August 31, 2001 sampling for Account No. 2506 are attached. These results are summarized as follows:

Sample ID Number	GRO (mg/kg)	Benzene (mg/kg)	Toluene (mg/kg)	Ethylbenzene (mg/kg)	Xylene (mg/kg)	DRO (mg/kg)	RRO (mg/kg)
2001-ASR-2506-308-SL	U	U	U	U	U	14.0	18.6
2001-ASR-2506-309-SL	U	U	U	U	U	U	U
2001-ASR-2506-310-SL	U	U	U	U	U	U	U
2001-ASR-2506-311-SL	U	U	U	U	U	U	U
2001-ASR-2506-312-SL	U	U	U	U	U	12.2	18.7
2001-ASR-2506-313-SLD	U	U	U	U	U	13.6	21.6
ADEC Level "A" Cleanup Criteria	50	-	-	-	-	100	2,000
ADEC Method Two Cleanup Criteria	-	0.02	5.5	5.4	78		-

Note: 1. U means undetected. 2. - Means not applicable.

Please be advised that Account No. 2506 meets ADEC Level "A" Cleanup Criteria for GRO, DRO, and RRO under Method One in 18 AAC 75.341. This account also meets ADEC Method Two cleanup levels for benzene, toluene, ethylbenzene and xylene (BTEX) in 18 AAC 75.341.

Samples No. 2001-ASR-2506-312-SL and 2001-ASR-2506-313-SLD are duplicates. The percentage difference for the DRO and RRO results for these samples is 10 percent and 13 percent, respectively. These results are acceptable under our quality control program and validates the laboratory results. All samples were collected following ADEC guidelines.

Sincerely,



Randy Easley
 President

Attachments



Oil Spill Consultants, Inc.

The Environmental Cleanup Company

September 27, 2001

Mr. James J. Rogers
 Environmental Manager
 Alaska Soil Recycling
 1040 O'Malley Road
 Anchorage, Alaska 99515

Subject: Laboratory Results for Third Party Sampling - Account No. 2506

Dear Mr. Rogers:

The results for our September 18, 2001 sampling for Account No. 2506 are attached. These results are summarized as follows:

Sample ID Number	GRO (mg/kg)	Benzene (mg/kg)	Toluene (mg/kg)	Ethylbenzene (mg/kg)	Xylene (mg/kg)	DRO (mg/kg)	RRO (mg/kg)
2001-ASR-2506-352-SL	U	U	0.032	U	0.073	18.0	34.1
2001-ASR-2506-353-SL	U	U	U	U	U	20.6	40.8
2001-ASR-2506-354-SL	U	U	U	U	U	23.3	36.7
2001-ASR-2506-355-SLD	U	U	U	U	U	21.8	37.2
ADEC Level "A" Cleanup Criteria	50	-	-	-	-	100	2,000
ADEC Method Two Cleanup Criteria	-	0.02	5.5	5.4	78		-

Note: 1. U means undetected. 2. - Means not applicable.

Please be advised that Account No. 2506 meets ADEC Level "A" Cleanup Criteria for GRO, DRO, and RRO under Method One in 18 AAC 75.341. This account also meets ADEC Method Two cleanup levels for benzene, toluene, ethylbenzene and xylene (BTEX) in 18 AAC 75.341.

Samples No. 2001-ASR-2506-354-SL and 2001-ASR-2506-355-SLD are duplicates. The percentage difference for the DRO and RRO results for these samples is 6 percent and 1 percent, respectively. The comparability for the duplicate samples is acceptable under our quality control program and validates the laboratory results. All samples were collected following ADEC guidelines.

Sincerely,



Randy Easley
 President

Attachments



APPENDIX C
Backfill Material Specifications
Compaction Test Results

ALASKA TEST LAB

A Division of DOWL LLC

Client: Jacobs Engineering
 Project: EAFB Soil Remediation Task 12
 Location: Summit Pit Import
 East Stockpile, North Side

MODIFIED PROCTOR
ASTM D 1557 C

W.O. A29428
 Lab No. 1338
 Received: 7/26/01
 Reported:

Engineering Classification: Poorly Graded GRAVEL with Sand, GP
Frost Classification: NES (MOA)

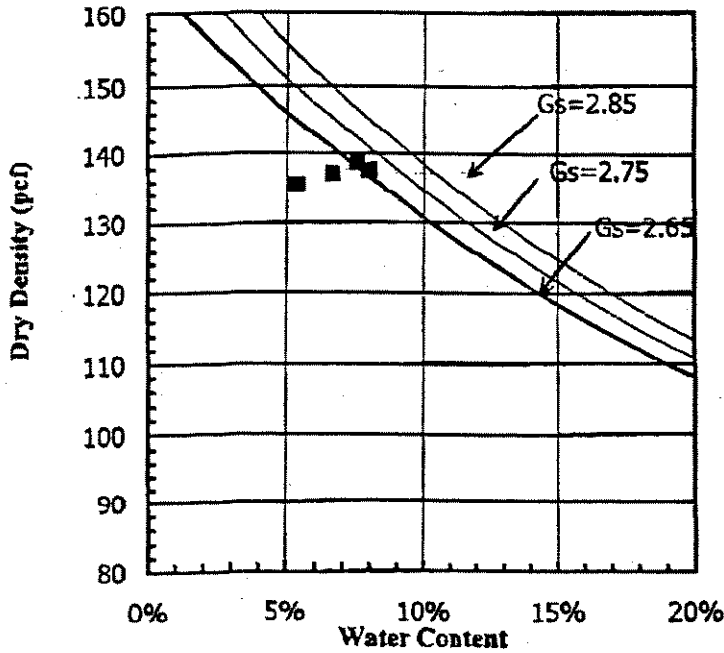

Uncorrected
 Maximum Density: 138.5 pcf
 Optimum Water Content: 8 %

Moist Preparation
 Mechanical Compaction

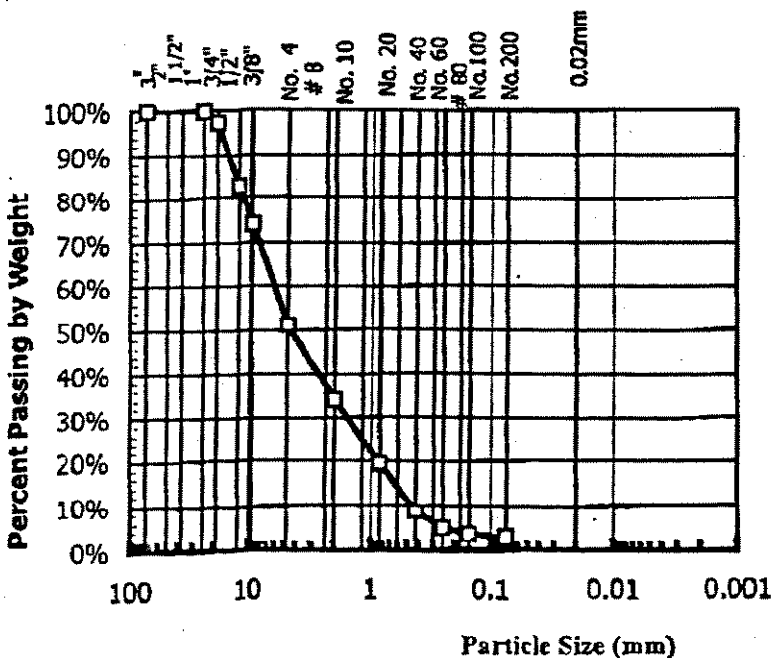

SIZE	PASSING	SPECIFICATION
+3 in Not Included in Test = -0%		
3"		
2"		
1 1/2"		
1"	100%	
3/4"	97%	
1/2"	83%	
3/8"	74%	
No. 4	51%	
Total Wt. = 13999g		
No. 8		
No. 10	34%	
No. 16		
No. 20	19%	
No. 30		
No. 40	9%	
No. 50		
No. 60	3%	
No. 80		
No. 100	4%	
No. 200	2.8%	
Total Wt. of Fine Fraction = 326.2g		
0.02 mm		

David L. Anderson

ALASKA TESTLAB

A Division of DOWL LLC

Client: Jacobs Engineering
 Project: EAFB Soil Remediation Task 12
 Location: Summit Pit Import
 East Stockpile, South Side

MODIFIED PROCTOR
ASTM D 1557 C

W.O. A29428
 Lab No. 1337
 Received: 7/26/01
 Reported:

Engineering Classification: Poorly Graded GRAVEL with Sand, GP
Frost Classification: NFS (MOA)

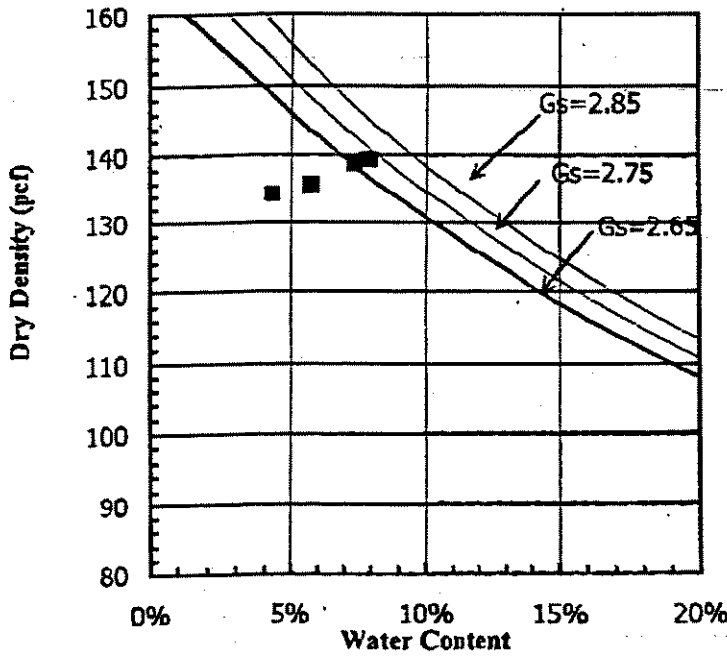

Uncorrected
 Maximum Density: 139.5 pcf
 Optimum Water Content: 8 %

Moist Preparation
 Mechanical Compaction

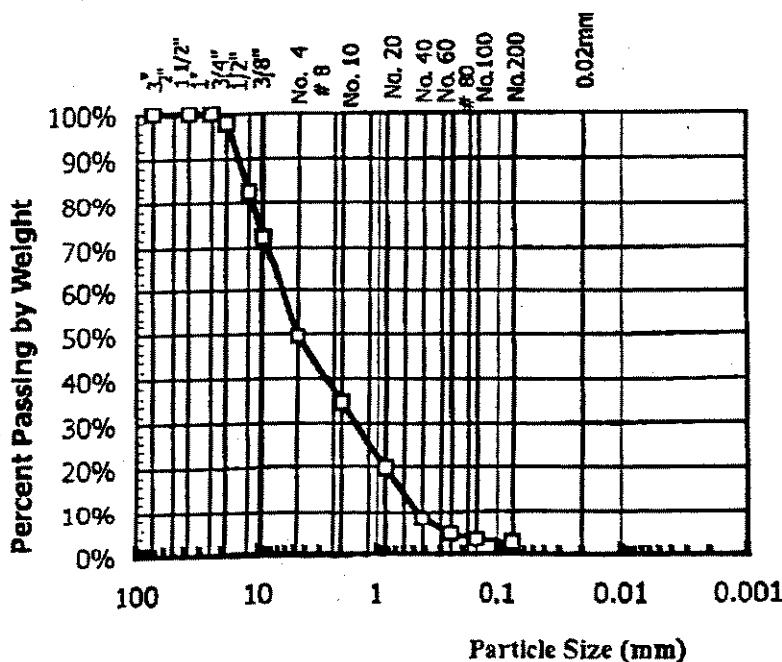

SIZE	PASSING	SPECIFICATION
+3 in Not Included in Test = -0%		
3"		
2"		
1 1/2"	100%	
1"	100%	
3/4"	98%	
1/2"	83%	
3/8"	72%	
No. 4	49%	
Total Wt. = 56808g		
No. 8		
No. 10	35%	
No. 16		
No. 20	20%	
No. 30		
No. 40	8%	
No. 50		
No. 60	5%	
No. 80		
No.100	3%	
No.200	2.7%	
Total Wt. of Fine Fraction = 333.3g		
0.02 mm		

David L. Andersen



Phone: 562-2000, Fax: 563-3953

IN PLACE DENSITY
 ASTM D2922 & D2216
 SOILS ASPHALT PAVING

Dispatch Date: 8-4-01
 Dispatch Time: 2:30
 Page 1 of 1

Client: CEI W.O.#: A29438
 Project: EAFB Instrument #: A-498
 Order taken by: AS Requested by: _____ Date: _____ Time: _____
 Test Locations Selected by: ATL Contractor Owner Tested by/date: AS 8/4/01
 Notification of Test Results Given To: _____
 Time Departed for Site: 2:30 Time Arrived Site: 2:40 Date: 8-4-01
 Time Departed Site: 3:45 Time Arrived Back: 4:05 Time: 3:45
 Standby Requested by (start/end): _____

MOA Permit No. _____

Checked by/date: _____

- | | | | |
|------------------------------------|------------------------------------|---|--|
| <input type="checkbox"/> Waterline | <input type="checkbox"/> Sewerline | <input type="checkbox"/> Storm Drain | <input type="checkbox"/> Electrical Line |
| <input type="checkbox"/> Gas Line | <input type="checkbox"/> Fuel Line | <input type="checkbox"/> Slab | <input type="checkbox"/> Footing |
| <input type="checkbox"/> Sidewalk | <input type="checkbox"/> Road | <input checked="" type="checkbox"/> Parking Lot | <input type="checkbox"/> Curb & Gutter |
| | | | <input type="checkbox"/> Other _____ |

No.	+3"	Gravel	Sand	-200	Probe	Bulk	Dry	Water	Proctor	% Compaction
1	-	50	45	5	-	144.3	135.4	6.5	139.5	97
Type: <u>Import Summit Pit Import E. side of Hanger II</u>								Lab		
Location: <u>Fuel tank backfill 85'S 24'E of SE corner of Hanger II</u>										(S.T. 407)
										Elevation: <u>3' BFG</u>

No.	+3"	Gravel	Sand	-200	Probe	Bulk	Dry	Water	Proctor	% Compaction
2	-	50	45	5	-	144.5	136.6	5.7	139.5	98
Type: <u>Import</u>								Lab		
Location: <u>Fuel tank backfill 90'S 25'E of SE corner of Hanger II</u>										(S.T. 407)
										Elevation: <u>2' BFG</u>

No.	+3"	Gravel	Sand	-200	Probe	Bulk	Dry	Water	Proctor	% Compaction
3	-	50	45	5	-	148.0	136.6	8.3	139.5	98
Type: <u>Import</u>								Lab		
Location: <u>Fuel tank backfill 88'S 30'E of SE corner of Hanger II</u>										(S.T. 407)
										Elevation: <u>1' BFG</u>

No.	+3"	Gravel	Sand	-200	Probe	Bulk	Dry	Water	Proctor	% Compaction
4	-	50	45	5	-	144.7	135.1	7.1	139.5	97
Type: <u>Import</u>								Lab		
Location: <u>Fuel tank backfill 88'S 28'E of SE corner of Hanger II</u>										(S.T. 407)
										Elevation: <u>Finish Grade</u>

Remarks: _____

Unit Price T & M

dencarb12001.doc

APPENDIX D
Data Quality Assessment
Analytical Data Package

Sample Summary Table

Location	Sample ID	Laboratory	Lab Sample ID	Collection Date	Matrix
JE01ELM-ST407SP01-01SO	EL-A200701	CTE	1014345001	7/11/01	SO
JE01ELM-ST407SP01-01SOD	EL-A200702	CTE	1014345002	7/11/01	SO
JE01ELM-ST407SP02-01SO	EL-A200703	CTE	1014345003	7/11/01	SO
JE01ELM-ST407SP03-01SO	EL-A200704	CTE	1014345004	7/11/01	SO
JE01ELM-TB03	EL-A200705	CTE	1014345005	7/11/01	SO

DATA QUALITY ASSESSMENT

Sample collection, handling, analysis and reporting procedures were followed as defined in the Field Sampling Plan (FSP) and Quality Assurance Project Plans (QAPP). Most data acceptance criteria were met with the few exceptions defined in this section.

The analytical data was provided by the laboratory in both hardcopy and electronic formats. One hundred percent of the analytical hardcopy data and fifty percent of the electronic data was reviewed. The primary laboratory, CT&E Environmental Services, Inc. (CT&E), supported the analytical requirements of the 2001 field effort.

The completeness check and electronic data review was done by Jacobs. This process included a review of the analytical methodology, chain of custody (COC) and sample receipt records, sample holding times, laboratory and field blank results, analytical reporting limits, surrogates, laboratory control samples, calibrations, matrix spikes and duplicates, run logs, and extraction logs. The data were reviewed against the Quality Assurance Project Plan and EPA *National Functional Guidelines* (EPA 1994, 1999).

The quality assurance project plan (QAPP), laboratory acceptance criteria and the Environmental Protection Agency (EPA) *National Functional Guidelines* (EPA 1994, 1999) were referenced by Jacobs to assess the data usability and apply validation qualifiers to the summary tables. The Jacobs project chemist performed a completeness check on the hardcopy data and reviewed the hardcopy and electronic data to evaluate comparability and accuracy. The review process did not include verification of calculations.

The analytical data quality objectives (DQO) for this field investigation shall be met when the quality of the sample data meet precision, accuracy, representativeness, completeness, comparability, and sensitivity (PARCCS) requirements as defined in the field sampling plan (FSP), QAPP, laboratory quality assurance project plan (LQAPP), and analytical methods. These DQO were evaluated by reviewing the following QA parameters and criteria:

- PRECISION

- Matrix Spike Duplicates (MSD); and
- Field Duplicates.

- ACCURACY

- Calibrations - initial and continuing; acceptance, frequency;
- Surrogates - recovery, frequency;
- Lab Control Samples/Spikes (LCS);
- Matrix Spikes (MS);
- Retention Times;
- Relative Response Factors (RRFs); Relative Standard Deviation (%RSD);
- Method Blanks;
- Tune Criteria gas chromatography/mass spectroscopy (GC/MS) - acceptability, frequency; and
- Internal Standards (GC/MS) - acceptability, frequency.

- REPRESENTATIVENESS

- Sample Chain-of-Custody;
- Holding Times and Preservation; and
- Work Plans.

- COMPARABILITY

- Standard Operating Procedures (SOPs); and
- Established analytical methods.

- COMPLETENESS

- Samples (field, QA, and QC);
- Data Packages (forms, runlogs, extraction logs, etc.); and
- Ninety-five percent completeness.

- SENSITIVITY

- Analytical laboratory reporting limits

All reported data within this package should be considered valid unless otherwise noted and may be biased (qualifications noted in the body of this report). The qualifiers used to flag data are defined as follows:

- “U” - synonymous with “ND” for nondetect; not detected above the reporting limit (practical quantitation limit); final numerical result becomes the reporting limit flagged with “U.”
- “J” - analyte was positively identified, but numerical value of concentration is approximate due to compromised quality control or inherent inability to analyze the sample (e.g. matrix effects).
- “UJ” - the analyte was not reported above the practical quantitation limit, but the reported quantitation limit is approximate (due to compromised quality control or inherent inability to analyze the sample).
- “UR” - the analyte was not detected above the reporting limit, but sample results were rejected due to significant deficiencies in quality control(s) or inherent ability to analyze the sample (e.g. matrix effects).

The qualifiers listed above, or “flags”, are hyphenated in the report to reflect the basic rationale behind the qualification (e.g. “J-S”). The following qualifiers were used in the text of this report to indicate which QA/QC protocols were not met:

- S - surrogate recovery;
- L - lab control sample;
- C - calibration;
- T - instrument 12-hour tuning criteria;
- M - matrix spike and/or spike duplicate;
- I - internal standard;
- B - method blank;
- H - holding times;
- P - incorrect or inadequate preservation methods;
- E - value exceeds instrument calibration range;
- TE – sample cooler temperatures; and
- UB/RL – although the analyte was detected, the result should be considered nondetected at the reporting limit or reported value due to potential laboratory contamination.

DATA QUALITY SUMMARY

In general, the overall quality of the data was acceptable. The data quality was determined as acceptable, estimated, or rejected. Acceptable data are associated with QC data that meet all QC criteria or with QC samples that did not meet QC criteria but data quality objectives were not affected. Estimated (J) results are considered inaccurate due to a bias created by matrix interference or QC acceptance criteria which were not met. Rejected data are not usable.

All Chain-of-Custody (COC) sample identification numbers include EL (Elmendorf – various sites), -A (Alaska), four numbers (COC number) followed by two additional numbers that identify the samples collected in sequence that are specific to the location and analytical suite of analyses (i.e. EL-A200701). This sample appears on COC number 2007, and is the first sample collected for GRO. For ease in referring to the results tables and readability of this report, the last six digits of the sample identification number will be used to identify each sample (i.e. 200701 would identify EL-A200701 found on COC # 2007). The original COC is on file in the Jacobs Anchorage office with the original data package. An extra dash was occasionally used on this project to separate the sample number from the COC number (e.g. EL-A2007-01) and will remain unchanged in this text as it appears in the analytical summary table, data tables, and COCs.

The term “positive result(s)” is used to identify all analytes that are detected above the laboratory reporting limit. The term “nondetected” refers to results that are less than the laboratory reporting limit and are therefore not reported by the laboratory. “All results” refers to both nondetected and positive results.

Details of the evaluation are provided in the following section by method and include the associated samples and analytes:

Gasoline Range Organics (GRO) AK 101. Overall, the quality of the data are acceptable with the following qualifications:

- Holding Times and Sample Handling: All holding time and sample handling criteria were met.
- Method Blanks: GRO was not detected in the method blanks.
- Reporting Limits: All minimum reporting limit requirements were met.
- Surrogates: BFB surrogate recovery exceeded recovery limits high for sample EL-A200703 due to matrix interference. Sample result is considered estimated (J-S).
- LCS: All acceptance criteria were met.
- Calibration: All acceptance criteria were met.
- MS/MSD: All acceptance criteria were met.
- Sample EL-A200701 and duplicate sample EL-A200702 GRO results agree.

Benzene, Toluene, Ethylbenzene, and Xylenes, BTEX by SW8260B. Overall, the quality of the data are acceptable with the following qualifications:

- Holding Times and Sample Handling: All holding time and sample handling criteria were met.
- Method Blanks: Target analytes were not detected in the method blanks; therefore, data were not qualified based on this criteria.
- Reporting Limits: All minimum reporting limit requirements were met.
- Surrogates: All acceptance criteria were met.
- LCS: All acceptance criteria were met.
- Calibration: All acceptance criteria were met.
- MS/MSD: All acceptance criteria were met
- Sample EL-A200701 and duplicate sample EL-A200702 BTEX results agree.

Diesel Range/Residual Range Organics (DRO/RRO) AK 102/103. Overall, the quality of the data are acceptable with the following qualifications:

- Holding Times and Sample Handling: All hold time criteria were met.
- Method Blanks: Target analytes were not detected in the method blanks; therefore, data were not qualified based on this criteria.
- Reporting Limits: All minimum reporting limit requirements were met.
- Surrogates: Surrogate recoveries for EL-A200701 and EL-A200702,exceeded limits due to matrix interference. Sample EL-A200703 exceeded surrogate recovery limits due to dilution. Sample results in these samples are considered estimated (J-S).
- LCS: All acceptance criteria were met with the exception of surrogate recoveries. Surrogate recoveries were biased high due to interference by method required petroleum spike. However, the data is not qualified on this basis.
- Calibration: All acceptance criteria were met.

- MS/MSD: EL-A200701 MS recovery of RRO exceeded recovery limits high due heterogeneous matrix. However, the data is not qualified on this basis.
- Sample EL-A200701 and duplicate sample EL-A200702 DRO/RRO results disagree. However, both sets of DRO/RRO results are already qualified as estimated due to surrogate recovery exceedances. The more conservative results from the primary sample (EL-A200701) should be reported.

Polynuclear Aromatic Hydrocarbons (PAH) SW8270C Selective Ion Monitoring (SIM). Overall, the quality of the data are acceptable with the following qualifications:

- Holding Times and Sample Handling: All holding time and sample handling criteria were met.
- Method Blanks: Target analytes were not detected in the method blanks; therefore, data were not qualified based on this criteria.
- Reporting Limits: All minimum reporting limit requirements were met.
- Surrogates: All acceptance criteria were met.
- LCS: All acceptance criteria were met.
- Calibration: All acceptance criteria were met.
- MS/MSD: EL-A200701 MS recoveries for Acenaphthalene, Flouranthene, Pyrene, and Benzo(b)fluoranthene exceeded recovery limits high, but RPDs were acceptable. PAHs were not detected in this sample; therefore, results are not qualified.
- Sample EL-A200701 and duplicate sample EL-A200702 PAH SIM results agree.

Metals, Arsenic, Cadmium, Chromium, Lead by SW6020. Overall, the quality of the data are acceptable with the following qualifications:

- Holding Times and Sample Handling: All holding time and sample handling criteria were met.
- Method Blanks: Target analytes were not detected in the method blanks; therefore, data were not qualified based on this criteria.
- Reporting Limits: All minimum reporting limit requirements were met.
- LCS: All acceptance criteria were met.
- Calibration: All acceptance criteria were met.
- MS/MSD: All acceptance criteria were met.
- Sample EL-A200701 and duplicate sample EL-A200702 results for all analyzed metals agree.

Considering these noncompliance issues the data are still considered usable. The overall project completeness goal of 95 percent was met.

	Location E01ELM-ST407SP01-01SO	JE01ELM-ST407SP01-01SOD	JE01ELM-ST407SP02-01SO
Sample ID	EL-A200701	EL-A200702	EL-A200703
Laboratory	CTE	CTE	CTE
Lab Sample ID	1014345001	1014345002	1014345003
Collection Date	7/11/01	7/11/01	7/11/01
Matrix	SO	SO	SO

Analyte	Method	Units						
Total Solids	A2540G	PERCENT	95	[0]	95.1	[0]	94.9	[0]
Gasoline Range Organics	AK101	MG/KG	1.94	[4.11]	1.45	[3.65]	43.8	[3.38]J-S
Diesel Range Organics	AK102	MG/KG	150	[10.6]J-S	29.8	[10.4]	972	[54.2]J-S
Residual Range Organics	AK103	MG/KG	488	[21.1]J-S	89.6	[20.9]J-S	251	[108]J-S
Acenaphthene	PAHSIM	UG/KG	ND	[4.85]	ND	[6.19]	-	-
Acenaphthylene	PAHSIM	UG/KG	ND	[4.85]	ND	[6.19]	-	-
Anthracene	PAHSIM	UG/KG	ND	[4.85]	ND	[6.19]	-	-
Benzo(a)anthracene	PAHSIM	UG/KG	ND	[4.85]	ND	[6.19]	-	-
Benzo(a)pyrene	PAHSIM	UG/KG	ND	[4.85]	ND	[6.19]	-	-
Benzo(b)fluoranthene	PAHSIM	UG/KG	ND	[4.85]	ND	[6.19]	-	-
Benzo(g,h,i)perylene	PAHSIM	UG/KG	ND	[4.85]	ND	[6.19]	-	-
Benzo(k)fluoranthene	PAHSIM	UG/KG	ND	[4.85]	ND	[6.19]	-	-
Chrysene	PAHSIM	UG/KG	ND	[4.85]	ND	[6.19]	-	-
Dibenzo(a,h)anthracene	PAHSIM	UG/KG	ND	[4.85]	ND	[6.19]	-	-
Fluoranthene	PAHSIM	UG/KG	ND	[4.85]	ND	[6.19]	-	-
Fluorene	PAHSIM	UG/KG	ND	[4.85]	ND	[6.19]	-	-
Indeno(1,2,3-cd)pyrene	PAHSIM	UG/KG	ND	[4.85]	ND	[6.19]	-	-
Naphthalene	PAHSIM	UG/KG	ND	[4.85]	ND	[6.19]	-	-
Phenanthrene	PAHSIM	UG/KG	1.6	[4.85] J	ND	[6.19]	-	-
Pyrene	PAHSIM	UG/KG	ND	[4.85]	ND	[6.19]	-	-
Benzene	SW8260B	MG/KG	ND	[0.0158]	ND	[0.0164]	ND	[0.0176]
Ethylbenzene	SW8260B	MG/KG	ND	[0.0304]	0.0101	[0.0315] J	0.0159	[0.0338] J
Toluene	SW8260B	MG/KG	0.0566	[0.0304]	0.0659	[0.0315]	0.0956	[0.0338]
m,p-Xylene (Sum of Isomers)	SW8260B	MG/KG	0.0386	[0.0304]	0.0422	[0.0315]	0.0908	[0.0338]
o-Xylene	SW8260B	MG/KG	0.01	[0.0304] J	0.0139	[0.0315] J	0.0338	[0.0338] J

	Location	JE01ELM-ST407SP03-01SO	JE01ELM-TB03
Sample ID	EL-A200704	EL-A200705	
Laboratory	CTE	CTE	
Lab Sample ID	1014345004	1014345005	
Collection Date	7/11/01	7/11/01	
Matrix	SO	SO	

Analyte	Method	Units				
Total Solids	A2540G	PERCENT	95.3	[0]	100	[0]
Gasoline Range Organics	AK101	MG/KG	1.53	[3.18] J	ND	[2.6]
Diesel Range Organics	AK102	MG/KG	ND	[10.7]	-	-
Residual Range Organics	AK103	MG/KG	7.47	[21.4] J	-	-
Acenaphthene	PAHSIM	UG/KG	-	-	-	-
Acenaphthylene	PAHSIM	UG/KG	-	-	-	-
Anthracene	PAHSIM	UG/KG	-	-	-	-
Benzo(a)anthracene	PAHSIM	UG/KG	-	-	-	-
Benzo(a)pyrene	PAHSIM	UG/KG	-	-	-	-
Benzo(b)fluoranthene	PAHSIM	UG/KG	-	-	-	-
Benzo(g,h,i)perylene	PAHSIM	UG/KG	-	-	-	-
Benzo(k)fluoranthene	PAHSIM	UG/KG	-	-	-	-
Chrysene	PAHSIM	UG/KG	-	-	-	-
Dibenzo(a,h)anthracene	PAHSIM	UG/KG	-	-	-	-
Fluoranthene	PAHSIM	UG/KG	-	-	-	-
Fluorene	PAHSIM	UG/KG	-	-	-	-
Indeno(1,2,3-cd)pyrene	PAHSIM	UG/KG	-	-	-	-
Naphthalene	PAHSIM	UG/KG	-	-	-	-
Phenanthrene	PAHSIM	UG/KG	-	-	-	-
Pyrene	PAHSIM	UG/KG	-	-	-	-
Benzene	SW8260B	MG/KG	0.01	[0.0134] J	ND	[0.0135]
Ethylbenzene	SW8260B	MG/KG	0.0134	[0.0258] J	ND	[0.026]
Toluene	SW8260B	MG/KG	0.102	[0.0258]	ND	[0.026]
m,p-Xylene (Sum of Isomers)	SW8260B	MG/KG	0.0685	[0.0258]	ND	[0.026]
o-Xylene	SW8260B	MG/KG	0.0216	[0.0258] J	ND	[0.026]



JACOBS ENGINEERING GROUP INC.

4300 B STREET SUITE 600, ANCHORAGE, ALASKA 99503-5922
TELEPHONE (907) 563-3322 FAX (907) 563-3320

CHAIN OF CUSTODY RECORD

USE A BALLPOINT PEN, BLACK INK, AND PRESS FIRMLY. INSTRUCTIONS ARE ON THE BACK

PROJECT NAME: Elmendorf SERA sites		LABORATORY NAME & ADDRESS: CT&E Environmental Services	
PROJECT NUMBER: 05m31201		200 W. Potter Drive	
WBS CODE:		Anchorage, AK 99518	
CONTRACT / D.O. No.			

SAMPLE NUMBER	COLLECTION		DATE	TIME	METHOD	TEMP	PRESERVATIVE	ANALYTES	REMARKS
	CONTAINER	CONTROL #							
① EL-A2007 01	WW	3	7/11/01	1007	402 glass method septum	40C	SO	AK101, SW8260B (BTEX)	M
EL-A2007 01	WW	3	7/11/01	1007	802 glass amber	40C	SO	AK102, AK103	M
EL-A2007 01	WW	3	7/11/01	1007	802 glass amber	40C	SO	SW800/7000 (AS, CD, CR and Pb), SW8270C SIM Pb)	M
② EL-A2007 02	WW	1	7/11/01	1009	402 glass method septum	40C	SO	AK101, SW8260B (BTEX)	
EL-A2007 02	WW	1	7/11/01	1009	802 glass amber	40C	SO	AK102, AK103	
EL-A2007 02	WW	1	7/11/01	1009	802 glass amber	40C	SO	SW800/7000 (AS, CD, CR and Pb), SW8270C SIM	
③ EL-A2007 03	WW	1	7/11/01	1210	402 glass method septum	40C	SO	AK101, SW8260B (BTEX)	
EL-A2007 03	WW	1	7/11/01	1210	802 glass amber	40C	SO	AK102, AK103	
④ EL-A2007 04	WW	1	7/11/01	1222	402 glass method septum	40C	SO	AK101, SW8260B (BTEX)	

-14/-15

COMMENTS:

COLLECTED & RELEASED BY <i>[Signature]</i>	DATE 7/13/01	TIME 17:05	TURNAROUND TIME 7 day	DATE	TIME
RECEIVED BY <i>[Signature]</i>	DATE 7/13/01	TIME 17:45	RELINQUISHED BY	DATE	TIME
RECORD RETURNED BY	DATE	TIME	SHIPPING NUMBER:		

1014345 RUSH



CT&E Environmental Services Inc.

Laboratory Division

Laboratory Analysis Report

200 W. Potter Drive
Anchorage, AK 99518-1605
Tel: (907) 562-2343
Fax: (907) 561-5301
Web: <http://www.cteesi.com>

Gloria Beckman
Jacobs Engineering Group
4300 B Street Suite 600
Anchorage, AK 99503

Work Order:	1014345 Elmendorf SERA Sites 05M31201
Client:	Jacobs Engineering Group
Report Date:	July 27, 2001

Enclosed are the analytical results associated with the above workorder.

As required by the state of Alaska and the USEPA, a formal Quality Assurance/Quality Control Program is maintained by CT&E. A copy of our Quality Control Manual that outlines this program is available at your request.

Except as specifically noted, all statements and data in this report are in conformance to the provisions set forth in our Quality Assurance Program Plan.

If you have any questions regarding this report or if we can be of any other assistance, please call your CT&E Project Manager at (907) 562-2343.

The following descriptors may be found on your report which will serve to further qualify the data.

- U Indicates the analyte was analyzed for but not detected.
- F Indicates an estimated value that falls below PQL, but is greater than the MDL.
- B Indicates the analyte is found in the blank associated with the sample.
- * The analyte has exceeded allowable limits.
- GT Greater Than
- D Secondary Dilution
- LT Less Than
- ! Surrogate out of range

SGS Member of the SGS Group (Societe Generale de Surveillance)

Case Narrative

Customer: JACOBSE

Jacobs Engineering Group

Project: 1014345

Elmendorf SERA Sites 05M31201

NPDL WO: NA

1014345001 PS

DRO/RRO - Unknown hydrocarbon with several peaks.
DRO/RRO - Surrogate recoveries are outside controls due to matrix interference.

1014345002 PS

DRO/RRO - Unknown hydrocarbon with several peaks.
DRO - Surrogate recovery is outside controls due to matrix interference.

1014345003 PS

DRO/RRO - Pattern consistent with weathered middle distillate.
DRO/RRO - Surrogate recoveries are outside controls due to matrix interference.
GRO/BTEX - Surrogate recovery is biased high due to matrix interference. Results are not affected.

1014345006 PS

DRO - Pattern consistent with weathered middle distillate.
GRO/BTEX - Surrogate recovery is biased high due to matrix interference. Results are not affected.

1014345007 PS

DRO - Pattern consistent with weathered middle distillate.
DRO - Surrogate recovery is outside controls due to matrix interference.
GRO/BTEX - Surrogate recovery is biased high due to matrix interference. Results are not affected.

1014345008 PS

DRO - Pattern consistent with weathered middle distillate.
DRO - Surrogate recovery is outside controls due to matrix interference.

1014345009 PS

DRO - Pattern consistent with weathered middle distillate.
DRO - Surrogate recovery is outside controls due to matrix interference.
GRO/BTEX - Surrogate recovery is biased high due to matrix interference. Results are not affected.

1014345010 PS

DRO - Unknown hydrocarbon with several peaks.

1014345011 PS

DRO - Pattern consistent with weathered middle distillate.
DRO - Surrogate recovery is outside controls due to matrix interference.

1014345014 BMS

DRO/RRO - Surrogate/s are biased high due to interference by method required petroleum spike.
PAHSIM - MS recovery for Acenaphthylene, Fluoranthene, Pyrene and Benzo(b)fluoranthene is outside QC goals.
The LCS/LCSD met all recovery and RPD goals. The results are not significantly affected.
8260 - Surrogate 4-Bromofluorobenzene is biased high and did not meet QC recovery goals. All internal standards met QC recovery goals.
RRO - MS does not meet recovery goals. Sample may not be homogeneous.

Case Narrative

Customer: JACOBSE

Jacobs Engineering Group

Project: 1014345

Elmendorf SERA Sites 05M31201

NPDL WO: NA

1014345015 BMSD

DRO/RRO - Surrogate/s are biased high due to interference by method required petroleum spike.

PAHSIM - MS recovery for Acenaphthylene, Fluoranthene, Pyrene and Benzo(b)fluoranthene is outside QC goals. The LCS/LCSD met all recovery and RPD goals. The results are not significantly affected.

PAHSIM - RPD for Acenaphthylene is outside QC goals. The LCS/LCSD met all recovery and RPD goals. The results are not significantly affected.

8260 - Surrogate 4-Bromofluorobenzene is biased high and did not meet QC recovery goals. All internal standards met QC recovery goals.

378244 LCS

DRO/RRO LCS/LCSD - Surrogate/s are biased high due to interference by method required petroleum spike.

379273 LCS

DRO/RRO LCS/LCSD - Surrogate/s are biased high due to interference by method required petroleum spike.

378245 LCSD

DRO/RRO LCS/LCSD - Surrogate/s are biased high due to interference by method required petroleum spike.

379274 LCSD

DRO/RRO LCS/LCSD - Surrogate/s are biased high due to interference by method required petroleum spike.

379167 CCV

PAHSIM - CCV recovery for Phenanthrene (biased high) and Anthracene (biased low) is outside QC goals. These compounds were not reported under this CCV. The results are not significantly affected.



CT&E Ref.# 1014345001
 Client Name Jacobs Engineering Group
 Project Name/# Elmendorf SERA Sites 05M31201
 Client Sample ID EL-A200701
 Matrix Soil/Solid
 Ordered By

Client PO#
 Printed Date/Time 07/27/2001 20:43
 Collected Date/Time 07/11/2001 10:07
 Received Date/Time 07/13/2001 17:45
 Technical Director Stephen C. Ede

Released By *Deborah Wall*

Sample Remarks:

DRO/RRO - Unknown hydrocarbon with several peaks.
 DRO/RRO - Surrogate recoveries are outside controls due to matrix interference.

Parameter	Results	PQL	Units	Method	Allowable Limits	Prep Date	Analysis Date	Init
<u>Solids</u>								
Total Solids	95.0	0.00	%	SM20 2540G			07/17/01	DMR
<u>Underground Storage Tank Metals</u>								
Arsenic	5.39	1.00	mg/Kg	SW846 6020		07/16/01	07/17/01	KGF
Cadmium	0.200 U	0.200	mg/Kg	SW846 6020		07/16/01	07/17/01	KGF
Chromium	30.0	1.00	mg/Kg	SW846 6020		07/16/01	07/17/01	KGF
Lead	6.12	0.200	mg/Kg	SW846 6020		07/16/01	07/17/01	KGF
<u>Volatile Fuels Department</u>								
Gasoline Range Organics	1.94F	4.11	mg/Kg	AK101 GRO		07/11/01	07/24/01	RMV
<u>Surrogates</u>								
1,4-Difluorobenzene <Surr>	95.6		%	AK101 GRO	60-120	07/11/01	07/24/01	RMV
4-Bromofluorobenzene <Surr>	81		%	AK101 GRO	50-150	07/11/01	07/24/01	RMV
<u>Semivolatile Organic Fuels Department</u>								
Diesel Range Organics	150	10.6	mg/Kg	AK102/103		07/20/01	07/23/01	MCM
Residual Range Organics GC	488	21.1	mg/Kg	AK102/103		07/20/01	07/23/01	MCM
<u>Surrogates</u>								
n-Triacontane-d62 <Surr>	219	!	%	AK102/103	50-150	07/20/01	07/23/01	MCM
5a Androstane <surr>	262	!	%	AK102/103	50-150	07/20/01	07/23/01	MCM
<u>Volatile Gas Chromatography/Mass Spectroscopy</u>								
Benzene	0.0158 U	0.0158	mg/Kg	BTEX by SW8260B		07/11/01	07/19/01	GMD



CT&E Ref.# 1014345001
Client Name Jacobs Engineering Group
Project Name/# Elmendorf SERA Sites 05M31201
Client Sample ID EL-A200701
Matrix Soil/Solid
Ordered By

Client PO#
Printed Date/Time 07/27/2001 20:43
Collected Date/Time 07/11/2001 10:07
Received Date/Time 07/13/2001 17:45
Technical Director Stephen C. Ede

Parameter	Results	PQL	Units	Method	Allowable Limits	Prep Date	Analysis Date	Init
<u>Semivolatile Organic GC/MS</u>								
Chrysene-d12 <surrogate>	92.5		%	PAH SIM	16-147	07/16/01	07/19/01	SPM



CT&E Ref.# 1014345002
 Client Name Jacobs Engineering Group
 Project Name/# Elmendorf SERA Sites 05M31201
 Client Sample ID EL-A200702
 Matrix Soil/Solid
 Ordered By

Client PO#
 Printed Date/Time 07/27/2001 20:43
 Collected Date/Time 07/11/2001 10:09
 Received Date/Time 07/13/2001 17:45
 Technical Director Stephen C. Ede

Parameter	Results	PQL	Units	Method	Allowable Limits	Prep Date	Analysis Date	Init
<u>Volatile Gas Chromatography/Mass Spectroscopy</u>								
Toluene	0.0659	0.0164	mg/Kg	BTEX by SW8260B		07/11/01	07/19/01	GMD
Ethylbenzene	0.0101F	0.0164	mg/Kg	BTEX by SW8260B		07/11/01	07/19/01	GMD
P & M -Xylene	0.0422	0.0164	mg/Kg	BTEX by SW8260B		07/11/01	07/19/01	GMD
o-Xylene	0.0139F	0.0164	mg/Kg	BTEX by SW8260B		07/11/01	07/19/01	GMD
<u>Surrogates</u>								
1,2-Dichloroethane-D4 <surr>	94.4		%	BTEX by SW8260B	74-133	07/11/01	07/19/01	GMD
Toluene-d8 <surr>	96.5		%	BTEX by SW8260B	78-134	07/11/01	07/19/01	GMD
4-Bromofluorobenzene <Surr>	89.6		%	BTEX by SW8260B	72-141	07/11/01	07/19/01	GMD
1,2-Difluoromethane <surr>	99.4		%	BTEX by SW8260B	78-128	07/11/01	07/19/01	GMD
<u>Semivolatile Organic GC/MS</u>								
Benzo(a)Anthracene	6.19 U	6.19	ug/Kg	PAH SIM		07/16/01	07/19/01	SPM
Naphthalene	6.19 U	6.19	ug/Kg	PAH SIM		07/16/01	07/19/01	SPM
Acenaphthylene	6.19 U	6.19	ug/Kg	PAH SIM		07/16/01	07/19/01	SPM
Acenaphthene	6.19 U	6.19	ug/Kg	PAH SIM		07/16/01	07/19/01	SPM
Phenanthrene	6.19 U	6.19	ug/Kg	PAH SIM		07/16/01	07/20/01	SPM
Fluoranthene	6.19 U	6.19	ug/Kg	PAH SIM		07/16/01	07/19/01	SPM
Pyrene	6.19 U	6.19	ug/Kg	PAH SIM		07/16/01	07/19/01	SPM
Benzo[b]Fluoranthene	6.19 U	6.19	ug/Kg	PAH SIM		07/16/01	07/19/01	SPM
Fluorene	6.19 U	6.19	ug/Kg	PAH SIM		07/16/01	07/19/01	SPM
Benzo[g,h,i]perylene	6.19 U	6.19	ug/Kg	PAH SIM		07/16/01	07/19/01	SPM
Anthracene	6.19 U	6.19	ug/Kg	PAH SIM		07/16/01	07/20/01	SPM
Chrysene	6.19 U	6.19	ug/Kg	PAH SIM		07/16/01	07/19/01	SPM
Benzo[k]fluoranthene	6.19 U	6.19	ug/Kg	PAH SIM		07/16/01	07/19/01	SPM
Benzo[a]pyrene	6.19 U	6.19	ug/Kg	PAH SIM		07/16/01	07/19/01	SPM
Indeno[1,2,3-c,d] pyrene	6.19 U	6.19	ug/Kg	PAH SIM		07/16/01	07/19/01	SPM
Dibenzo[a,h]anthracene	6.19 U	6.19	ug/Kg	PAH SIM		07/16/01	07/19/01	SPM
<u>Surrogates</u>								
Naphthalene-d8 <surr/IS>	74.1		%	PAH SIM	10-138	07/16/01	07/19/01	SPM
Acenaphthene-d10 <surr/IS>	83.9		%	PAH SIM	10-147	07/16/01	07/19/01	SPM



CT&E Ref.# 1014345003
Client Name Jacobs Engineering Group
Project Name/# Elmendorf SERA Sites 05M31201
Client Sample ID EL-A200703
Matrix Soil/Solid
Ordered By

Client PO#
Printed Date/Time 07/27/2001 20:43
Collected Date/Time 07/11/2001 12:10
Received Date/Time 07/13/2001 17:45
Technical Director Stephen C. Ede

Released By [Signature]

Sample Remarks:

DRO/RRO - Pattern consistent with weathered middle distillate.
DRO/RRO - Surrogate recoveries are outside controls due to matrix interference.
GRO/BTEX - Surrogate recovery is biased high due to matrix interference. Results are not affected.

Table with 10 columns: Parameter, Results, PQL, Units, Method, Allowable Limits, Prep Date, Analysis Date, Init. Rows include Solids (Total Solids), Volatile Fuels Department (Gasoline Range Organics, Surrogates), Semivolatile Organic Fuels Department (Diesel Range Organics, Residual Range Organics, Surrogates), and Volatile Gas Chromatography/Mass Spectroscopy (Benzene, Toluene, Ethylbenzene, P & M -Xylene, o-Xylene).

Surrogates



CT&E Ref.# 1014345004
 Client Name Jacobs Engineering Group
 Project Name/# Elmendorf SERA Sites 05M31201
 Client Sample ID EL-A200704
 Matrix Soil/Solid
 Ordered By

Client PO#
 Printed Date/Time 07/27/2001 20:43
 Collected Date/Time 07/11/2001 12:22
 Received Date/Time 07/13/2001 17:45
 Technical Director Stephen C. Ede

Released By *Deborah Hall*

Sample Remarks:

Parameter	Results	PQL	Units	Method	Allowable Limits	Prep Date	Analysis Date	Init
Solids								
Total Solids	95.3	0.00	%	SM20 2540G			07/17/01	DMR
Volatile Fuels Department								
Gasoline Range Organics	1.53F	3.18	mg/Kg	AK101 GRO		07/11/01	07/24/01	RMV
Solvents								
1,4-Difluorobenzene <Surr>	95.7		%	AK101 GRO	60-120	07/11/01	07/24/01	RMV
4-Bromofluorobenzene <Surr>	78.9		%	AK101 GRO	50-150	07/11/01	07/24/01	RMV
Semivolatile Organic Fuels Department								
Diesel Range Organics	10.7 U	10.7	mg/Kg	AK102/103		07/16/01	07/17/01	MCM
Residual Range Organics GC	7.47F	21.4	mg/Kg	AK102/103		07/16/01	07/17/01	MCM
Surrogates								
n-Triacontane-d62 <Surr>	109		%	AK102/103	50-150	07/16/01	07/17/01	MCM
5a Androstane <surr>	123		%	AK102/103	50-150	07/16/01	07/17/01	MCM
Volatile Gas Chromatography/Mass Spectroscopy								
Benzene	0.0100F	0.0134	mg/Kg	BTEX by SW8260B		07/11/01	07/19/01	GMD
Toluene	0.102	0.0134	mg/Kg	BTEX by SW8260B		07/11/01	07/19/01	GMD
Ethylbenzene	0.0134	0.0134	mg/Kg	BTEX by SW8260B		07/11/01	07/19/01	GMD
P & M -Xylene	0.0685	0.0134	mg/Kg	BTEX by SW8260B		07/11/01	07/19/01	GMD
o-Xylene	0.0216	0.0134	mg/Kg	BTEX by SW8260B		07/11/01	07/19/01	GMD
Surrogates								
1-chloroethane-D4 <surr>	92.1		%	BTEX by SW8260B	74-133	07/11/01	07/19/01	GMD
Toluene-d8 <surr>	97.5		%	BTEX by SW8260B	78-134	07/11/01	07/19/01	GMD



CT&E Ref.# 1014345005
 Client Name Jacobs Engineering Group
 Project Name/# Elmendorf SERA Sites 05M31201
 Client Sample ID EL-A200705
 Matrix Soil/Solid
 Ordered By

Client PO#
 Printed Date/Time 07/27/2001 20:43
 Collected Date/Time 07/11/2001 9:30
 Received Date/Time 07/13/2001 17:45
 Technical Director Stephen C. Ede

Released By *Deborah Wall*

Sample Remarks:

Parameter	Results	PQL	Units	Method	Allowable Limits	Prep Date	Analysis Date	Init
Solids								
Total Solids	100	0.00	%	SM20 2540G			07/25/01	DMR
Volatile Fuels Department								
Gasoline Range Organics	2.60 U	2.60	mg/Kg	AK101 GRO		07/11/01	07/22/01	RMV
Surrogates								
1,4-Difluorobenzene <Surr>	88.3		%	AK101 GRO	60-120	07/11/01	07/22/01	RMV
4-Bromofluorobenzene <Surr>	50.5		%	AK101 GRO	50-150	07/11/01	07/22/01	RMV
Volatile Gas Chromatography/Mass Spectroscopy								
Benzene	0.0135 U	0.0135	mg/Kg	BTEX by SW8260B		07/11/01	07/19/01	GMD
Toluene	0.0135 U	0.0135	mg/Kg	BTEX by SW8260B		07/11/01	07/19/01	GMD
Ethylbenzene	0.0135 U	0.0135	mg/Kg	BTEX by SW8260B		07/11/01	07/19/01	GMD
P & M -Xylene	0.0135 U	0.0135	mg/Kg	BTEX by SW8260B		07/11/01	07/19/01	GMD
o-Xylene	0.0135 U	0.0135	mg/Kg	BTEX by SW8260B		07/11/01	07/19/01	GMD
Surrogates								
1,2-Dichloroethane-D4 <surr>	99.3		%	BTEX by SW8260B	74-133	07/11/01	07/19/01	GMD
Toluene-d8 <surr>	99.8		%	BTEX by SW8260B	78-134	07/11/01	07/19/01	GMD
4-Bromofluorobenzene <Surr>	97.9		%	BTEX by SW8260B	72-141	07/11/01	07/19/01	GMD
Dibromofluoromethane <surr>	104		%	BTEX by SW8260B	78-128	07/11/01	07/19/01	GMD

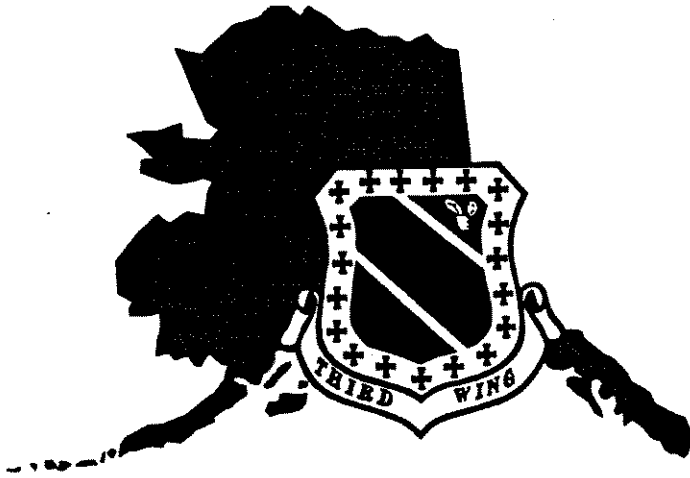

**UNITED STATES AIR FORCE
ELMENDORF AIR FORCE BASE, ALASKA**

ENVIRONMENTAL COMPLIANCE PROGRAM

AFIDs 575, 576, AND 578
SERA PHASE IV ST407
RELEASE INVESTIGATION REPORT

DRAFT FINAL

MARCH 1997

CONTENTS

1.0 INTRODUCTION	1-1
1.1 ST407 Site Background	1-1
1.2 Regional Setting	1-4
1.3 Report Outline	1-6
2.0 METHODS	2-1
2.1 Initial Activities	2-1
2.2 Borings	2-2
2.3 Soil Sampling	2-2
2.4 Field Quality Control Samples	2-5
2.5 Sampling Control	2-6
2.6 Decontamination	2-7
2.7 Disposition of Investigation-Derived Waste	2-7
2.8 Survey	2-8
2.9 Soil Gas Survey	2-8
2.10 Air Permeability	2-8
2.11 Data Analysis	2-9
2.11.1 Petroleum Hydrocarbon Data	2-9
2.11.2 Inorganic Data	2-9
2.11.3 Soil Gas Concentrations	2-10
2.11.4 Soil Air Permeability and Anisotropy	2-10
3.0 RESULTS	3-1
3.1 Release Investigation Results	3-1
3.2 Bioventing Treatability Study	3-4
4.0 CONCLUSIONS	4-1
5.0 REFERENCES	4-2

APPENDICES

LIST OF TABLES

2-1	Soil Sample Analytical Summary for ST407	2-5
2-2	Matrix Score Cleanup Levels	2-9
3-1	ST407 Soil Contaminant Results	3-3
3-2	ST407 Soil Nutrient, TOC, and pH Results	3-3
3-3	ST407 Soil Gas Survey Results	3-4

LIST OF FIGURES

1-1	Elmendorf AFB Location Map	1-2
1-2	Composite Site Location Map	1-3
1-3	Generalized Groundwater Flow Direction	1-5
2-1	Typical Bioventing Well Completion	2-3
2-2	Typical Piezometer Completion	2-4
3-1	ST407 Site Map Showing Soil Sample Results	3-2

LIST OF ACRONYMS AND ABBREVIATIONS

AAC	Alaska Administrative Code
ADEC	Alaska Department of Environmental Conservation
AFB	Air Force Base
AFID	Air Force Identification Number
ASTM	American Society for Testing and Materials
ATH	Ambient Temperature Headspace
bgs	Below ground surface
BTEX	Benzene, Toluene, Ethylbenzene, and Total Xylenes
CERCLA	Comprehensive Environmental Response, Compensation, and Liability Act
cfm	Cubic feet per minute
DRO	Diesel Range Organics
ENSR	ENSR Corporation
EPA	U.S. Environmental Protection Agency
GRO	Gasoline Range Organics
JP-4	Jet propulsion fuel No. 4
MAP	Management Action Plan
MS	Matrix Spike
MSD	Matrix Spike Duplicate
OU	Operable Unit
PID	Photoionization Detector
POL	Petroleum, Oils, and Lubricants
ppm	Parts per million
QC	Quality Control
RRO	Residual Range Organics
SERA	State-Elmendorf Environmental Restoration Agreement
TOC	Total organic carbon
USACE	United States Army Corps of Engineers
USAF	United States Air Force
UST	Underground Storage Tank
VOC	Volatile Organic Compounds

1.0 INTRODUCTION

This report presents results from a release investigation and associated treatability study conducted at site ST407 on Elmendorf Air Force Base (AFB), Alaska (Figure 1-1), contaminated with petroleum, oil, and lubricants (POL) products.

The primary chemicals of concern at the site are petroleum hydrocarbons, including gasoline range organics (GRO); diesel range organics (DRO); residual range organics (RRO); and benzene, toluene, ethylbenzene, and total xylenes (BTEX).

The objectives of the release investigation were to estimate the extent of soil contamination, evaluate the potential for the site to be a source of groundwater contamination, and conduct a preliminary bioventing treatability study.

1.1 ST407 Site Background

ST407 is a former underground storage tank (UST) site near Building 43-575, south of Burns Road. Three steel USTs were located at the site. Their Air Force Identification (AFID) number, capacity, and former contents are provided below:

<u>AFID</u>	<u>Capacity</u>	<u>Contents</u>
AFID 575	500 gallons	used synthetic hydraulic oil
AFID 576	1000 gallons	used synthetic turbine oil
AFID 578	2000 gallons	JP-4 tank

The site location is identified in Figure 1-2, Composite Site Location Map.

The USTs were removed in August 1994 (USAF 1995). Soil contamination was identified in 5 of the 10 excavation base and sidewall closure samples, with maximum soil concentrations of 9000 mg/Kg DRO, 420 mg/Kg GRO, and 22.7 mg/Kg total BTEX. The UST removal report concluded that a release investigation should be conducted to further delineate the extent of petroleum hydrocarbons in site soil and groundwater, as well as investigate potential remedial alternatives.

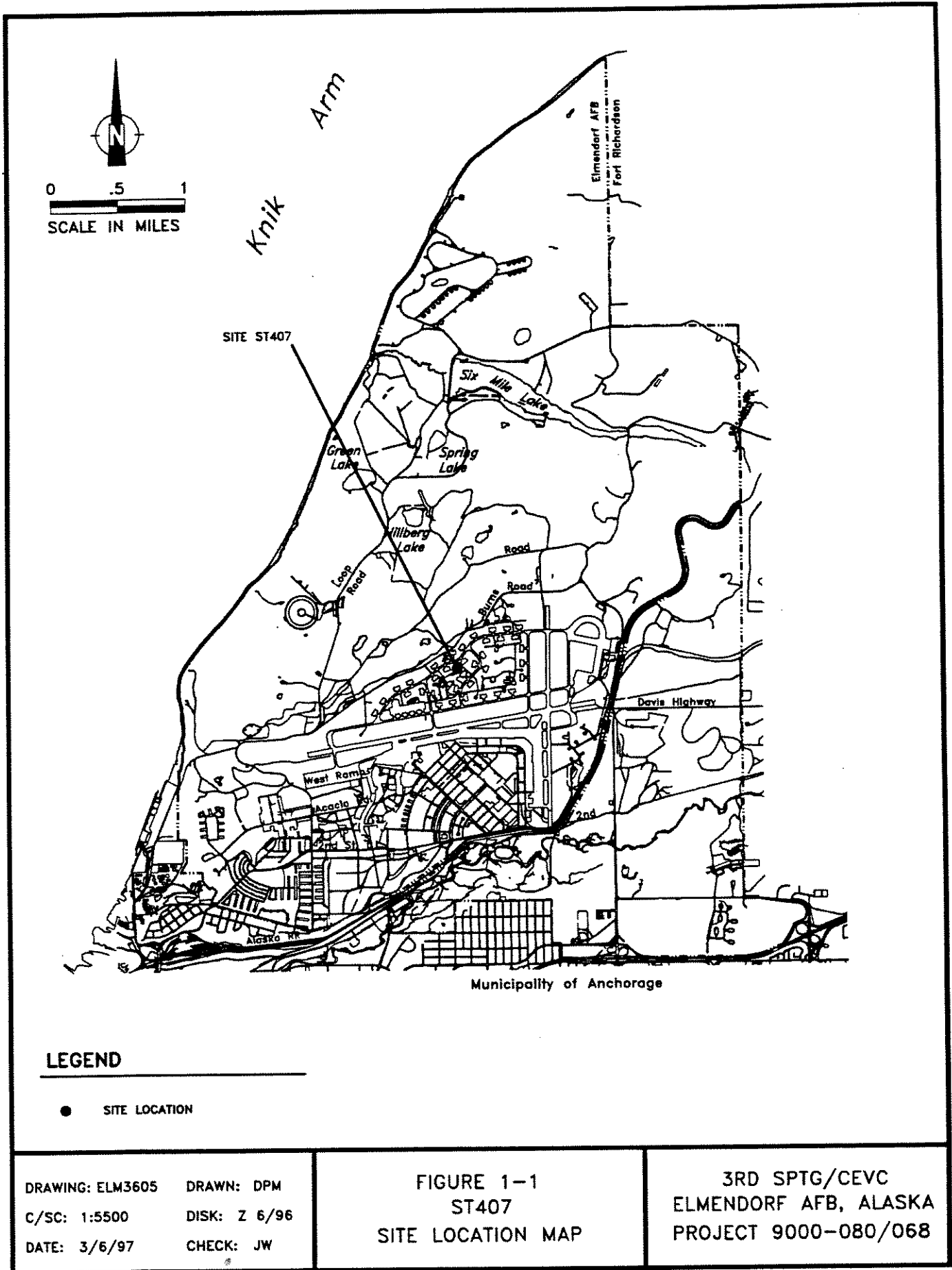

1-3

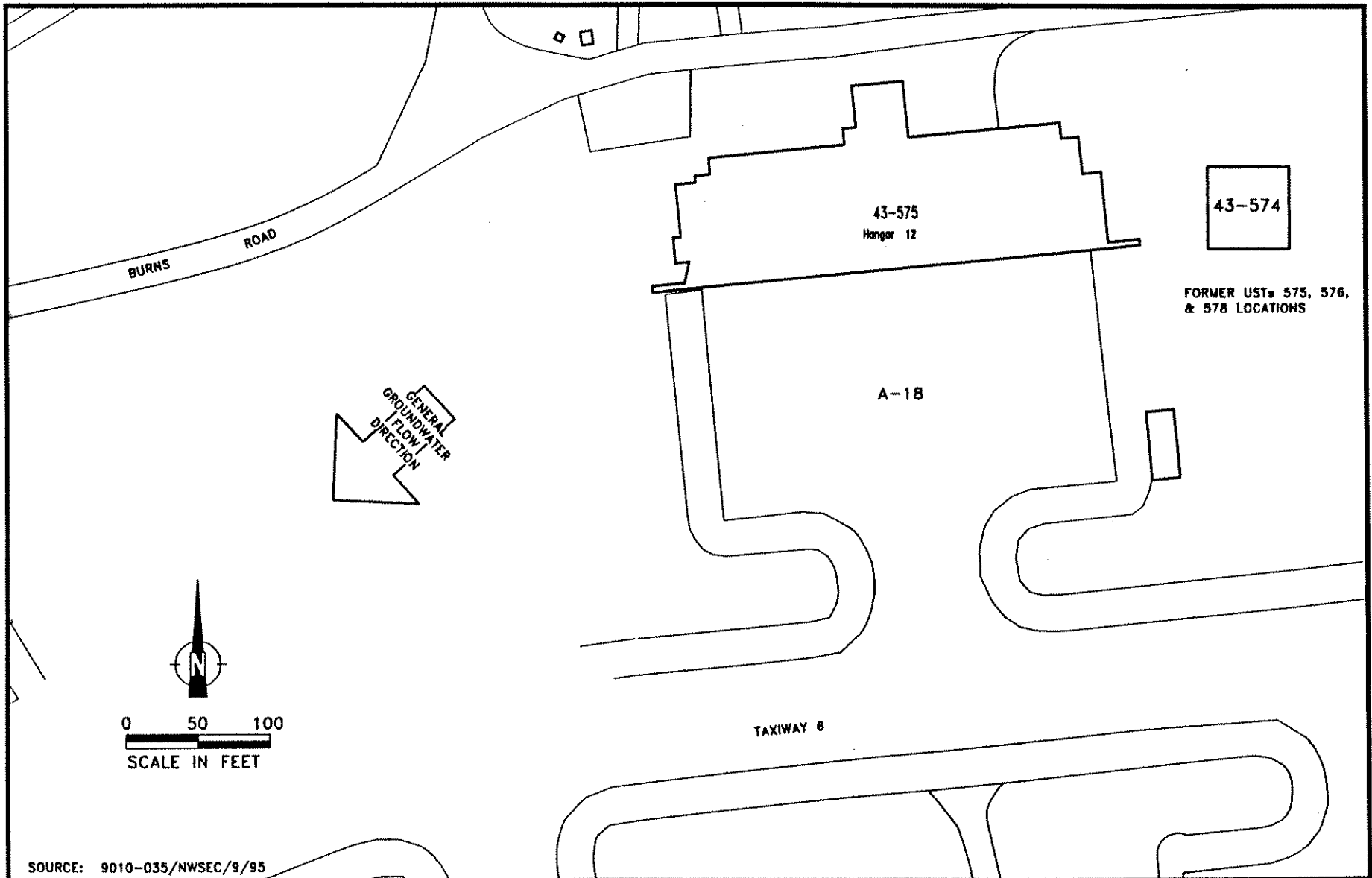

SOURCE: 9010-035/NWSEC/9/95

DRAWING: ST407_1A
C/SC: 1:100
DATE: 3/13/97

DRAWN: SSR
DISK: Z 9/96
CHECK: P.R.

FIGURE 1-2
ST407
SITE MAP

3RD SPTG/CEVC
ELMENDORF AFB, ALASKA
PROJECT 9000-068/080

An Alaska Department of Environmental Conservation (ADEC) cleanup score of Level B was determined from the results of the UST removals. The hydraulic gradient is anticipated to be to the southwest based on the basewide groundwater monitoring program (USAF 1996a). Base well 16 is the nearest water well, located approximately 5000 feet downgradient from the site.

1.2 Regional Setting

Elmendorf AFB is located in southcentral Alaska, along the head of Cook Inlet and adjacent to the City of Anchorage. Elmendorf AFB comprises 13,130 acres, bordered to the north and west by Knik Arm of Cook Inlet, to the east by Fort Richardson, and to the south by the City of Anchorage. Land use at Elmendorf AFB is varied. Nearly half (6053 acres) of the Base has been developed for airfield operations (runways, taxiways, and maintenance areas) and support operations, including housing and recreational facilities. The remaining acreage (7077 acres) is basically undeveloped and includes 1416 acres of wetlands, lakes, and ponds.

Elmendorf AFB lies within the Cook Inlet-Susitna Lowlands, which is bordered on the west by the Alaska Range and on the east by the Kenai, Chugach, and Talkeetna mountain ranges. The Elmendorf terminal moraine traverses the AFB northeast to southwest. The southern boundary of the Elmendorf Moraine is a ridge line running along the north side of the east-west runway.

ST407 is located south of the Elmendorf Moraine on the glacio-fluvial deposits of an outwash plain. This outwash plain consists primarily of crudely bedded sand-gravel mixtures with minor silt. A thin overlying layer of loess is locally present.

Groundwater flow is divided by the Elmendorf Moraine. Groundwater flow north of the moraine is to the northwest towards Knik Arm of Cook Inlet. Groundwater flow south of the moraine is south and west toward Ship Creek. Flow along the moraine generally matches the slope of the surface topography (USAF 1996a). Figure 1-3 presents the generalized groundwater flow direction. Contaminated groundwater within the area defined as the Operable Unit 5 (OU-5) model area in Figure 1-3 is managed under a Comprehensive Environmental Response, Compensation, and Liability Act (CERCLA) agreement between Elmendorf AFB, ADEC, and the U.S. Environmental Protection Agency (EPA).

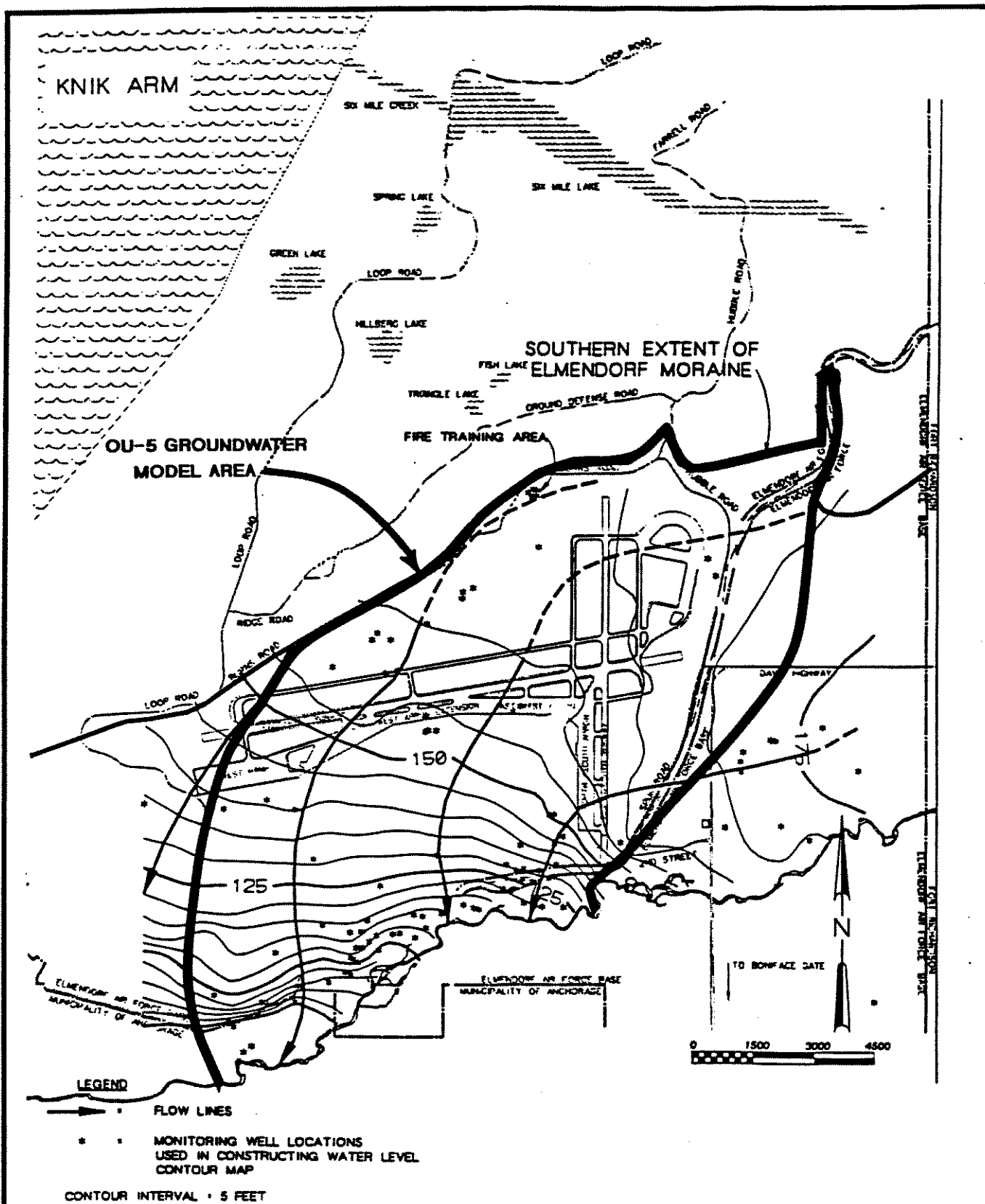

FIGURE 1-3
GENERALIZED GROUNDWATER
FLOW DIRECTION

3RD SPTG/CEVC
ELMENDORF AFB, ALASKA
PROJECT 9000-080/068

1.3 Report Outline

This report is divided into the following sections:

Section 2.0 summarizes methods employed in the release investigation and treatability study at ST407. The reader is referred to the work plan prepared for this investigation for detailed method presentations. Section 2.0 also discusses methods and standards used in data interpretation.

Sections 3.0 present the release investigation/treatability study results for the site, including site description and investigation results.

Section 4.0 presents a list of documents cited in this report.

The Data Assessment Report, including a discussion of Data Quality, DRO and RRO chromatograms, and chromatogram interpretations, is provided in Appendix A.

2.0 METHODS

This section summarizes field methods and techniques that were used in the release investigation and bioventing treatability study at site ST407. Full details are provided in the work plan prepared for this investigation (USAF 1996b), which was reviewed by the U.S. Air Force (USAF), the U.S. Army Corps of Engineers (USACE), and ADEC. The work was conducted in accordance with the work plan, and site-specific health and safety plan (USAF 1996c). The Work Plan was prepared following the guidelines, as applicable, of:

- State-Elmendorf Environmental Restoration Agreement (SERA) (ADEC and USAF 1992).
- State-Elmendorf Storage Tank Agreement (ADEC and USAF 1993).
- Basewide policies and procedures for fieldwork at Elmendorf AFB presented in the Management Action Plan (MAP) (USAF 1994).
- Title 18 of the Alaska Administrative Code, Part 75 (18 AAC 75), *Oil and Hazardous Substance Pollution Control Regulations* (ADEC 1992).
- 18 AAC 78, *Underground Storage Tanks* (ADEC 1995a).
- 18 AAC 78, *Underground Storage Tanks Procedures Manual* (ADEC 1995b).
- *Basewide Environmental Staging Facility Operation and Maintenance Plan* (USAF 1993).

2.1 Initial Activities

The field program for the release investigation at ST407 was planned based on information obtained from previous site assessments, historical aerial photographs, facility drawings, basewide monitoring reports, and correspondence between USAF and ADEC. Critical information included the contaminant type and source, presumed groundwater flow direction, potential contaminant receptors, and infrastructure constraints. Utility clearances and dig permits were obtained for the site prior to drilling or excavation. The site was visually inspected for surface features and conditions to assist in locating borings.

2.2 Borings

The standard SERA IV release investigation field program included drilling and sampling four borings at each single tank site. Additional borings were installed at locations with more than one former UST or where field results indicated that additional information was required to adequately screen the site. Borings were usually drilled to the groundwater surface. In some instances drilling was terminated prior to encountering groundwater due to aquitards or lack of apparent contaminant vertical migration. Generally, one boring at each site was completed as an air injection well, and the remaining three borings were completed as soil gas/temperature monitoring arrays (piezometers). Borings were grouted following installation in instances where field observations and preliminary laboratory analytical results indicated that no contamination was present. Borings and wells were installed using standard methods (USAF 1996b). Figures 2-1 and 2-2 display typical well and piezometer completion details.

2.3 Soil Sampling

Soil samples were collected at 5-foot intervals from a 2.5-inch-diameter split-spoon sampler equipped with stainless steel sleeves advanced ahead of the auger flights during drilling. One of the center sleeves from each sampler was capped and sealed with Teflon sheets, then immediately placed in a cooler with freeze packs and maintained at approximately 4°C awaiting the field-screening results.

Soil samples were field screened using ambient temperature headspace (ATH) analysis with a photoionization detector (PID) in accordance with the ADEC UST procedures manual (ADEC 1995b). The PID was maintained in accordance with the manufacturer's specifications and was calibrated with 100 parts per million (ppm) isobutylene once daily at a minimum.

The sample just above the water table and the sample with the highest ATH screening results were selected from each boring for laboratory analysis. Table 2-1 summarizes soil analyses conducted at site ST407. The split-spoon sampler was decontaminated between each sample as detailed in Section 2.6.

Preliminary GRO, DRO, and BTEX results were obtained from the analytical laboratory on a 48-hour turn-around basis. This information was used to guide boring completion and establish additional boring locations as required. Samples not chosen for laboratory analysis were placed with the soil cuttings awaiting final disposition.

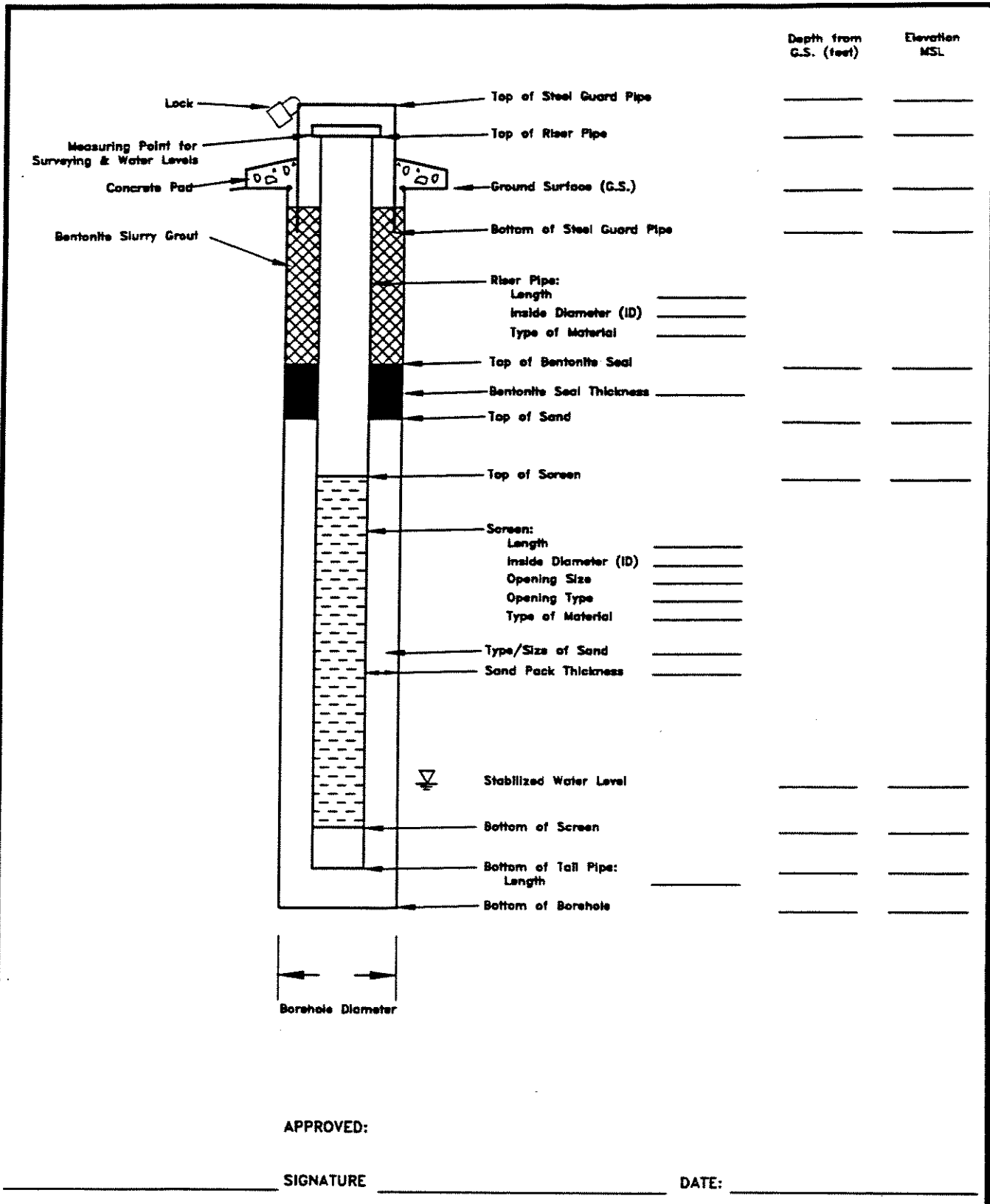

DRAWING: MWDET DRAWN: SSR
 C/SC: 1:1 DISK: Z 6/96
 DATE: 12/4/96 CHECK: P.R.

FIGURE 2-1
TYPICAL BIOVENTING
WELL COMPLETION

3RD SPTG/CEVC
ELMENDORF AFB, ALASKA
PROJECT 9000-068/080

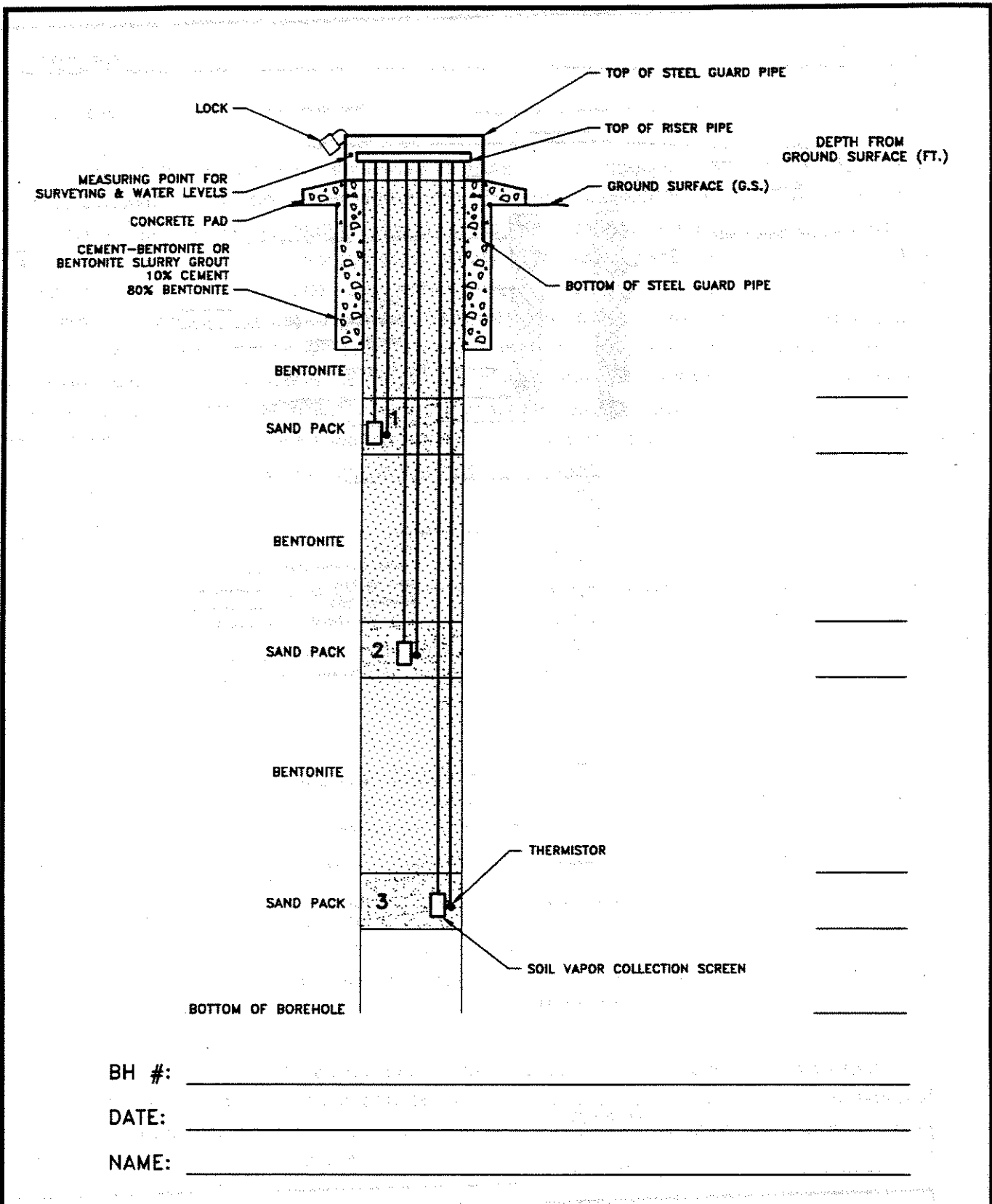

DRAWING: WELL4	DRAWN: SSR	FIGURE 2-2 TYPICAL PIEZOMETER COMPLETION	3RD SPTG/CEVC ELMENDORF AFB, ALASKA PROJECT 9000-080/068
C/SC: 1:1	DISK: Z 4/96		
DATE: 12/11/96	CHECK: PR		

Table 2-1. Soil Sample Analytical Summary for ST407.

Analyte	Method	Number of Samples
RRO	AK103.1 (standard TAT)	2/boring
DRO	AK102.1 (standard TAT)	2/boring
GRO	AK101.1 (standard TAT)	2/boring
DRO	AK101.1 (48 hour TAT)	1/boring
GRO	AK101.1 (48 hour TAT)	1/boring
BTEX	EPA 8020 (48 hour TAT)	1/boring
TOC	EPA 9060	~ 2/site
Nitrate	Mehlich III/SM4500	~ 2/site
Ammonia Ion Salicylate	Mehlich III/350.1	~ 2/site
Total Phosphate	Mehlich III/365.2	~ 2/site
Particle Size	ASTM D422-63	~ 2/site
pH	EPA 9045	~ 2/site
ASTM = American Society for Testing and Materials. BTEX = Benzene, toluene, ethylbenzene, and total xylenes. DRO = Diesel range organics. GRO = Gasoline range organics. RRO = Residual range organics. TAT = Turn-around time. TOC = Total organic carbon.		

2.4 Field Quality Control Samples

Field duplicates were collected at a 10 percent frequency for all analytes. Field duplicates were collected from the same sample sleeve, placed into separate containers, and submitted blind to the laboratory. Decontamination blanks were collected by rinsing the split spoon following decontamination with deionized water and collecting the rinsate. Methanol and aqueous trip blanks were included for GRO/BTEX samples at a frequency of one each per sample cooler. Trip blanks of analyte-free media accompanied each batch of samples and were returned unopened to the laboratory.

2.5 Sampling Control

Samples were tracked with chain-of-custody records from sampling through analysis. Samples were assigned unique field sample numbers using an alphanumeric system. Each sample tracking number consisted of a three-segment alphanumeric code that identifies the sampling location, the sample identifier, the type of sample, and the quality control (QC) identifier. The sample numbers were as follows:

- 1) Site Designation. The first segment of the sample identification number is the three-digit site number.
- 2) Location Designation. The next four characters represent the location within the site where the samples were obtained, namely: AANN, where A = alpha code designating the type of sample, and N = the sequential number assigned. The following codes were used during this investigation:

BH = Borehole
PZ = Piezometer/Monitoring Array
WL = Well

- 3) Matrix Code. The next two characters indicate the sample matrix:

DC = Drill Cuttings
SO = Soil
SQ = Soil/Solid Quality Control Matrix
WQ = Water Quality Control Matrix

- 4) Sample Depth. The next set of numerals indicate the depth below the surface to the top of the soil sample collection interval in feet and tenths of feet (e.g., 2.5 or 17.5; this part of the code is used only for soil samples).

- 5) Sample Type. The next set of characters represent the field sample type:

EB# = Equipment Blank
FD# = Field Duplicate
N# = Normal Environmental
TB# = Trip Blank
MTB# = Methanol Trip Blank
MS# = Lab Matrix Spike

SD# = Lab Matrix Spike Duplicate
TP# = Test Pit Sample

The # symbol represents a numeral that was sequentially assigned by additional sample types taken from one location. Laboratory matrix spike and matrix spike duplicates on a single sample were identified together as a matrix spike/matrix spike duplicate (MS/MSD) sample type.

The following example designates the first borehole soil sample collected at 5 feet below ground surface (bgs) at ST407:

407BH0ISO5.0N

2.6 Decontamination

All field equipment coming in contact with potentially contaminated soil or used for sampling was decontaminated before and after use. Clean, solvent-resistant gloves were worn by persons decontaminating tools and equipment. Soil sampling tools, including split spoons, were cleaned by the following process:

- 1) scrub with a solution of Alconox® and warm water.
- 2) rinse twice in clean water.
- 3) rinse with methanol.
- 4) rinse with deionized or distilled water.

Auger flights, rods, and bits were decontaminated between boreholes by cleaning with high pressure hot water.

2.7 Disposition of Investigation-Derived Waste

Water produced during drilling and completion of monitoring wells and decontamination water was containerized in truck-mounted bulk storage tanks or drums and transported to Elmendorf AFB Environmental Staging Facility. The water was processed through the on-site conditioning system and discharged via sanitary sewer system to the Anchorage wastewater treatment system.

Soil cuttings were placed in drums and stored at the Elmendorf AFB Environmental Staging Facility until analytical data for the soil were received. Soil disposition was coordinated through direction received from the USAF and USACE project managers. Soil with contaminant

concentrations below ADEC 18 AAC 78 cleanup Level A was disposed at a former Elmendorf soil waste municipal landfill, which accepts clean fill for cover. Soil contaminated above ADEC cleanup Level A was disposed at an approved thermal treatment facility following receipt of written approval from ADEC.

Disposable protective clothing, disposable bailers, and other similar supplies were disposed at the Municipality of Anchorage landfill.

2.8 Survey

Borings and monitoring wells installed during these investigations were surveyed by an Alaska-registered surveyor. Survey data were established relative to the Municipality of Anchorage datum and the USAF identified benchmark (TTAN7) located on Elmendorf AFB. The vertical datum for this survey was based on the Alaska State Plan coordinates. This control is the same datum used for the 1986 Elmendorf Master Plan and for the SERA Phase I and II investigations.

2.9 Soil Gas Survey

An initial soil gas oxygen (O₂), carbon dioxide (CO₂), and volatile organic compound (VOC) survey was conducted at least 2 weeks after completing piezometer and air injection well installation and prior to any air injection. Soil gas samples were collected from all site monitoring wells and soil gas monitoring points, and analyzed for VOCs, O₂, and CO₂ using a PID and a portable O₂/CO₂ indicator. Soil gas measurements were conducted by connecting a small (0.5 to 1.0 cubic feet per minute [cfm]) diaphragm pump to the monitoring point/well. The point was purged for an appropriate period, generally 2 to 3 tube/well volumes. Typical purge times were 3 minutes for points connected with 3/8-inch inside-diameter (ID) tubing and 5 minutes for 2-inch ID monitoring wells. Following purging, soil gas was analyzed for O₂, CO₂, and VOCs with direct reading meters. Meters were either connected directly to the well head/monitoring points or samples were collected from the exhaust of the purge pump into Tedlar bags and subsequently analyzed.

2.10 Air Permeability

An air permeability test was conducted at the site by injecting air into the air-injection well over a 20-minute to 4-hour period with a Rotron EN404 regenerative blower. Steady-state pressure was then monitored at the wellhead and all soil gas monitoring points, and wellhead injection velocity was measured. Differential pressure measurements were collected using Magnehelic® differential pressure gauges, and flow rates were measured using an Alnor® velometer.

2.11 Data Analysis

This section describes data interpretation techniques and standards. Data quality control methods and results are described in the Data Assessment Report, which is provided in Appendix A.

2.11.1 Petroleum Hydrocarbon Data

ATH/PID results were interpreted as qualitative data for field sample screening and extrapolating the extent of vadose petroleum hydrocarbon contamination. ATH/PID values above 10 ppm in combination with odor and elevated analytical results from associated samples were generally interpreted as positive indicators of petroleum hydrocarbons. Elevated ATH/PID values not accompanied by petroleum odor or petroleum hydrocarbons detected in laboratory analyses were attributed to interference from condensing humidity.

Soil petroleum hydrocarbon concentrations were compared to standards provided in the 18 AAC 78.315, Table E - Matrix Score Sheet, as summarized in Table 2-2 below.

Table 2-2. Matrix Score Cleanup Levels.

Matrix Score	Cleanup Level in mg/kg				
	GRO	DRO	RRO	Benzene	BTEX
Level A	50	100	2000	0.1	10
Level B	100	200	2000	0.5	15
Level C	500	1000	2000	0.5	50
Level D	1000	2000	2000	0.5	100

2.11.2 Inorganic Data

Nitrogen and phosphorus concentrations were compared to optimal bioavailable nutrient concentrations of 400 mg/Kg nitrogen and 40 mg/Kg phosphorus (Walworth and Reynolds 1995), and 6.5 to 8.0 pH (Hinchee et al. 1992).

2.11.3 Soil Gas Concentrations

Typical background soil gas oxygen concentrations are between 15 and 21 percent. Oxygen concentrations below 15 percent were considered to indicate oxygen as a primary degradation rate limited factor. Carbon dioxide concentrations are subject to inorganic sources and sinks, and were evaluated as a secondary qualitative indicator (Hinchee et al. 1992).

2.11.4 Soil Air Permeability and Anisotropy

Soil air permeability was estimated for the injection well using two-dimensional radial flow to a partially penetrating well in an unsealed vadose zone, with an upper atmospheric boundary and a lower impermeable boundary (groundwater). Air permeability test data were fitted to the steady-state pressure and flow based on the pressure solution obtained by Shan et al. (1992):

$$P^2 - P_{atm}^2 = \frac{Q_v P^* \mu}{2\pi k_a (L - l)} \ln \left\{ \frac{z-l+\sqrt{r^2+(z-l)^2}}{z-L+\sqrt{r^2+(z-L)^2}} \cdot \frac{z+L+\sqrt{r^2+(z+L)^2}}{z+l+\sqrt{r^2+(z+l)^2}} \right\} \\ - \sum_{n=1}^{\infty} (-1)^n \ln \left\{ \frac{z-2nb+L+\sqrt{r^2+(z-2nb+L)^2}}{z-2nb+l+\sqrt{r^2+(z-2nb+l)^2}} \cdot \frac{z-2nb-L+\sqrt{r^2+(z-2nb-L)^2}}{z-2nb-l+\sqrt{r^2+(z-2nb-l)^2}} \right\} \quad (1) \\ \cdot \ln \left\{ \frac{z+2nb-L+\sqrt{r^2+(z+2nb-L)^2}}{z+2nb-l+\sqrt{r^2+(z+2nb-l)^2}} \cdot \frac{z+2nb+L+\sqrt{r^2+(z+2nb+L)^2}}{z+2nb+l+\sqrt{r^2+(z+2nb+l)^2}} \right\}$$

where:	P	=	absolute pressure [ML ⁻¹ T ⁻²]
	P_{atm}	=	atmospheric pressure [ML ⁻¹ T ⁻²]
	Q_v	=	volumetric flow rate [L ³ T ⁻¹]
	P^*	=	pressure at point of flow measurement [ML ⁻¹ T ⁻²]
	μ	=	dynamic viscosity [ML ⁻¹ T ⁻¹]
	k_a	=	air permeability [L ²]
	l	=	depth to the top of the well screen [L]
	L	=	depth to the bottom of the well screen [L]
	r	=	horizontal radial coordinate [L]
	z	=	vertical coordinate [L]
	b	=	vadose zone thickness [L]

The series summation in equation (1) converges in approximately 10 or 20 terms.

Particle travel times were calculated for the injection well based on flow rates at groundwater under design air flow rates, estimated air permeability, and impermeable surface conditions. The estimated radial distances for the well are reported as 0.3 pore-volume exchanges per day. The required flow rate was calculated via:

$$r = \frac{\sqrt{Q_v t_{xc}}}{\pi r b n_a} \quad (2)$$

where: Q_v = volumetric flow rate at atmospheric pressure
 r = radius of the treatment zone in feet
 b = vadose zone thickness in feet
 n_a = air-filled porosity of the soil (volume/volume)
 t_{xc} = the time required for one pore volume exchange, in minutes

Equation (2) is based on the assumption of incompressible flow, which is valid for applied vacuums or pressures less than about 0.1 atmospheres (about 40 inches of water column).

3.0 RESULTS

3.1 Release Investigation Results

The ST407 release investigation was conducted in June 1996. The surface above the former tank locations at ST407 was unpaved at the time of the release investigation, and was surrounded by concrete and covered by gravel. Three corrugated, perforated drain pipes are installed in the site area. No significant surface stains were observed. The former USTs location was determined by the gravel area and the UST removal coordinates.

Six borings were completed at ST407, including one bioventing air injection well (407WL01), four soil gas monitoring arrays (407PZ01 through 407PZ04), and one boring that was grouted following installation (407BH01). Boring locations and analytical results are displayed in Figure 3-1. Boring details are provided on boring logs in Appendix B. Groundwater was encountered at approximately 42 feet bgs. Site soils consist of sand and gravel typical to the Elmendorf outwash plain. Soil samples contained elevated ATH/PID readings and smelled of petroleum hydrocarbons from all samples collected from boring 407WL01. For this reason analytical results were compared to ADEC Level A cleanup standards. Field screening results for petroleum hydrocarbons were negative for all other borings.

Soil petroleum hydrocarbon analytical results are summarized on Table 3-1 and Figure 3-1 and fully reported in Appendix C. Soil contamination above ADEC Level A cleanup standards was detected in 3 of the 12 normal soil samples collected at ST407, with maximum concentrations of 450 mg/Kg RRO, 2600 mg/Kg DRO, 257 mg/Kg GRO, 0.15 mg/Kg benzene, and 3.55 mg/Kg total BTEX. Chromatograms were not conclusive, but were indicative of weathered middle distillates. Other soil physical and chemical results are presented on Table 3-2.

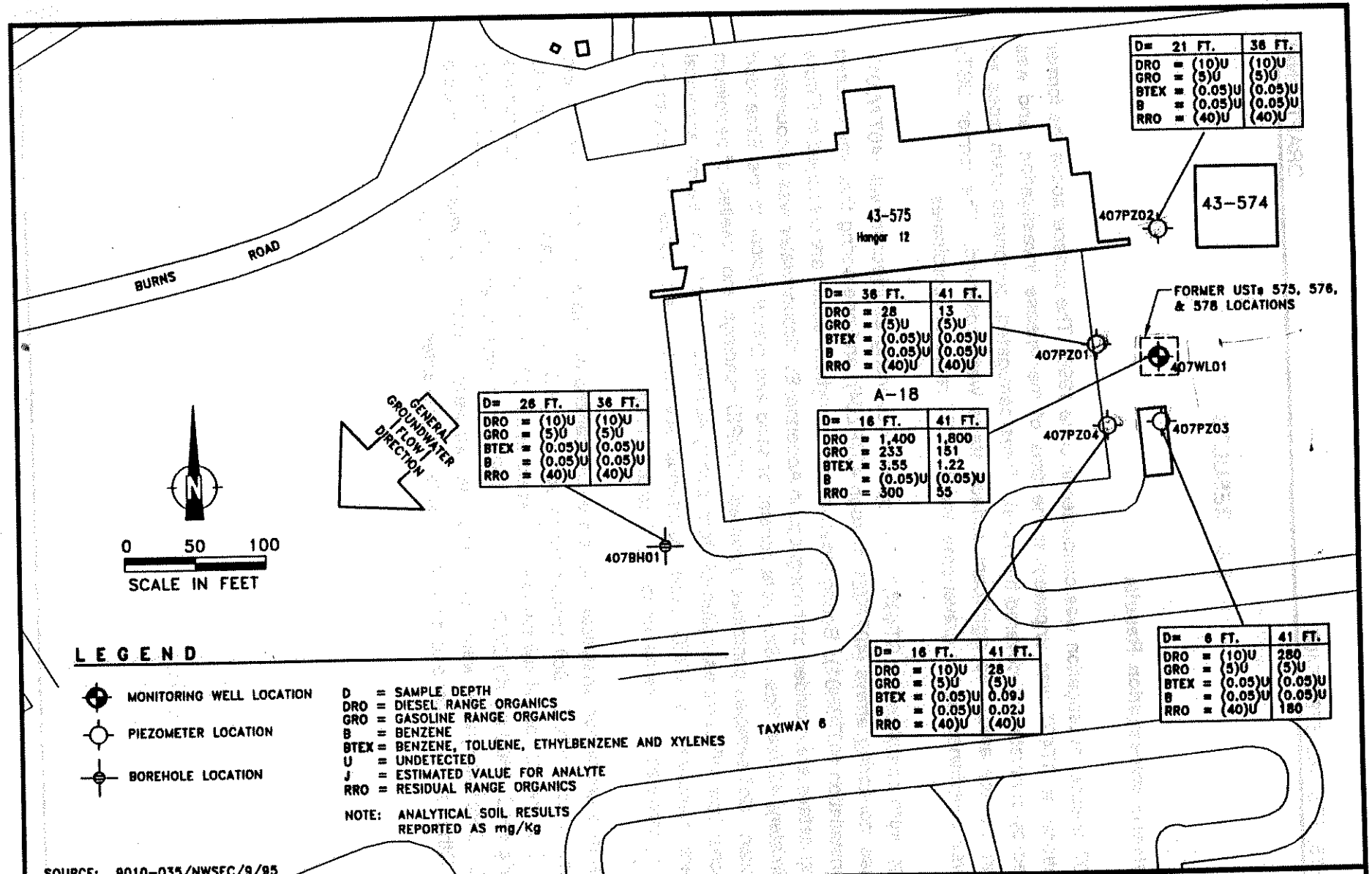

FIGURE 3-1
ST407
SITE MAP SHOWING
SOIL SAMPLE RESULTS

3RD SPTG/CEVC
ELMENDORF AFB, ALASKA
PROJECT 9000-068/080

DRAWING: ST407_1
C/SC: 1:100
DATE: 2/27/97

DRAWN: SSR
DISK: Z 9/96
CHECK: P.R.

Table 3-1. ST407 Soil Contaminant Results.*

Sample ID	Benzene EPA 8020a	BTEX EPA 8020a	GRO AK101.0	DRO AK102.0	RRO AK103.0
407BH01SO26.0N	(0.05) U	(0.05) U	(5) U	(10) U	(40) U
407BH01SO26.0N DUP	(0.05) U	(0.05) U	(5) U	(10) U	(40) U
407BH01SO36.0N	(0.05) U	(0.05) U	(5) U	(10) U	(40) U
407PZ01SO36.0N	(0.05) U	(0.05) U	(5) U	28	(40) U
407PZ01SO41.0N	(0.05) U	(0.05) U	(5) U	13	(40) U
407PZ02SO21.0N	(0.05) U	(0.05) U	(5) U	(10) U	(40) U
407PZ02SO36.0N	(0.05) U	(0.05) U	(5) U	(10) U	(40) U
407PZ03SO6.0N	(0.05) U	(0.05) U	(5) U	(10) U	(40) U
407PZ03SO41.0N	(0.05) U	(0.05) U	(5) U	280 F	180
407PZ04SO16.0N	(0.05) U	(0.05) U	(5) U	(10) U	(40) U
407PZ04SO41.0N	0.02 J	0.09 (J)	(5) U	28	(40) U
407WL01SO16.0N	(0.05) U	3.55	233 F	1400 D	300
407WL01SO16.0N DUP	0.15	3.26	257 G	2600 F	450
407WL01SO41.0N	(0.05) U	1.22	151 H	1800 I	55

* All results in mg/Kg.
 DUP = Duplicate sample.
 J = Estimated.
 U = Not detected (detection limit).

Table 3-2. ST407 Soil Nutrient, TOC, and pH Results.*

Sample ID	Nitrate-Nitrite 353.2	TKN 351.3	Ammonium 350.3	Phosphate 365.3	TOC D4129	pH 150.1
407WL01SO16.0N	(0.4) U	269	(0.5) U	(20) U	0.11	7.7
407WL01SO41.0N	(0.4) U	94.8	(0.5) U	(20) U	0.09	8.6
407WL01SO41.0N DUP	(0.4) U	116	(0.5) U	(20) U	0.07	8.7

* All units mg/Kg except pH.
 U = Not detected (detection limit).
 TKN = Total Kjeldahl nitrate.
 TOC = Total organic carbon.

3.2 Bioventing Treatability Study

Soil gas samples were collected and analyzed from all sampling locations at ST407. The results are presented in Table 3-3. Oxygen concentrations were above 10 percent in sampling locations except for 407WL01 and 24 feet bgs in 407PZ02. Elevated carbon dioxide concentrations were detected at all sampling locations except for 36 feet bgs in 402PZ01. VOC concentrations were near baseline concentrations except for 407WL01, which contained 62.6 ppm VOCs.

Air permeability of $2.6 \times 10^{-5} \text{ cm}^2$ and a horizontal to vertical anisotropy ratio of 8 were modelled for ST407 based on air injection into 407WL01 at approximately 100 cfm. At an injection rate of 100 cfm, a radial treatment zone of approximately 40 feet will receive 0.3 pore volume exchanges per day using permeable surface cover parameters.

Table 3-3. ST407 Soil Gas Survey Results.

Location	Depth (ft)	O ₂ (%)	CO ₂ (%)	VOC (ppm)	Temperature (°C)	Pressure (Inches H ₂ O)
407WL01	30-40	10	>5	62.6		2.9
407PZ01	12	15	4.6	1.0	11.5	0.03
	24	14	4.8	1.4	9	0.05
	36	21	0	0.8	7	0.10
407PZ02	12	11	>5	6.2		0.05
	24	8	>5	7.2		0.09
	36	15	>5	5.2		0.12
407PZ03	12	13.5	3.8	2.8		0.02
	24	14.5	3.2	3.4		0.04
	36	14.0	4.0	1.0		0.05
407PZ04	12	14.0	4.2	0.8		0.04
	24	13.5	4.4	2.4		0.05
	36	13.5	4.7	0.4		0.09
Flowrate = 103 cfm						

4.0 CONCLUSIONS

Site disposition recommendations for AFIDs 575, 576, and 578 at ST407 will be submitted under separate cover pending the completion of risk assessment work on the affected areas. The ADEC Oil and Hazardous Material Incident Report, Preliminary Risk Evaluation, and Release Investigation Summary Form are provided in Appendix D.

5.0 REFERENCES

- Alaska Department of Environmental Conservation (ADEC). 1992. *Oil and Hazardous Substance Pollution Control Regulations*. 18 AAC 75, May 14, 1992.
- _____. 1995a. *Underground Storage Tanks*. 18 AAC 78.
- _____. 1995b. *Underground Storage Tanks Standard Procedures Manual*. 18 AAC 78. November 3, 1995.
- Alaska Department of Environmental Conservation and the U.S. Air Force (ADEC and USAF). 1992. *State-Elmendorf Environmental Restoration Agreement*. U.S. Department of Defense, Elmendorf AFB, Anchorage, Alaska. October 1, 1992.
- _____. 1993. *State-Elmendorf Underground Storage Tank Agreement*. U.S. Department of Defense, Elmendorf AFB, Anchorage, Alaska. November 29, 1993.
- Hinchee, R.E., S.K. Ong, R.N. Miller, D.C. Downey, and R. Frandt. 1992. *Protocol for a Field Treatability Test for Bioventing*. Prepared for U.S. Air Force, Brooks AFB, Texas.
- Shan, C., R. Falta, and I. Javandel. 1992. "Analytical Solutions for Steady State Gas Flow to a Soil Vapor Extraction Well." *Water Resources Research*. Vol. 28, pp. 1105-1120.
- _____. 1993. *Basewide Environmental Staging Facility Operation and Maintenance Plan, Draft*. Elmendorf AFB, Alaska. February 1993.
- _____. 1994. *Environmental Restoration Program, Management Action Plan, Revision 2, FINAL*. Elmendorf AFB, Alaska. December 1994.
- _____. 1995. *Draft Underground Storage Tank Closure Assessment, Delivery Order 0006, Buildings 43-574 and 43-575, Elmendorf AFB, Alaska*. February. Prepared by Shannon and Wilson, Inc.
- _____. 1996a. *Basewide Support and Groundwater Monitoring Program, Annual Report of Groundwater Sampling Activities*. Final March 1996

_____. 1996b. *SERA Phase IV Site Assessment Work Plan*. Prepared by ENSR for U.S. Air Force, Elmendorf Air Force Base, Environmental Compliance Program. Final, April 1996.

_____. 1996c. *Site Safety and Health Plan for SERA Phase IV Site Assessment Work Plans*. Prepared by ENSR for U.S. Air Force, Elmendorf Air Force Base, Environmental Compliance Program. Final, April 1996.

Walworth, J.L. and C.M. Reynolds. 1995. "Bioremediation of a Petroleum-Contaminated Cryic Soil: Effects of Phosphorus, Nitrogen, and Temperature." *Journal of Soil Contamination*. 4(3):299-310.

APPENDIX B
BORING LOGS

AFIDs 575, 576 and 578

ST407

BORING LOG

BORING NUMBER: 407BH01

CLIENT: US AIR FORCE

BORING DEPTH (ft): 39

SCREEN LENGTH (ft):

PROJECT NAME: SERA IV

BORING DIAMETER (in): 8

SCREEN TYPE:

SITE: ST407

WELL DEPTH (ft):

SLOT SIZE (in):

JOB NUMBER: 0000-068

WELL DIAMETER (in):

FILTER PACK:

LOGGED BY: P. Moore APPROVED BY: P. Ribbens

REFERENCE ELEVATION (ft): 197.5

DATE STARTED: 6/19/96

DRILLED BY: Hughes Drilling

CASING STICKUP (in):

DATE COMPLETED: 6/19/96

METHOD: 4.25 in. HOLLOW STEM AUGER

FIELD PARTY: P. Ribbens

NORTHING: 2653188.2

EASTING: 1674343.7

DEPTH feet	LENGTH RECOVERY	SAMP. NO.	SAMP. TYP.	BLOWS/FT.	PID (ppm)	GRAPHIC LOG	SOIL CLASS	DESCRIPTION AND REMARKS	WELL DIAGRA
			SS	24	0.0		SW	Lithology same as above, no hydrocarbon odor.	
25		407BH01 ISO26. ON	SS	29	2.4		SW	Olive green-brown GRAVELLY SAND (SW), up to 40% gravel, medium dense, damp, no hydrocarbon odor.	
30			SS	38	2.1		SM	Light yellow-brown SILTY SAND (SM), coal, medium dense, damp, no hydrocarbon odor.	
							SW	GRAVELLY SAND (SW)	
35		407BH01 ISO36. ON	SS	54	2.4		SW	Olive green GRAVELLY SAND (SW), angular gravel and broken cobbles, well graded sand, very dense, damp.	
40								End of boring at 40 feet.	

BORING LOG

CLIENT: US AIR FORCE

PROJECT NAME: SERA IV

SITE: ST407

JOB NUMBER: 9000-068

LOGGED BY: P. Moore APPROVED BY: P. Ribbens

DRILLED BY: Hughes Drilling

METHOD: 4.25 in. HOLLOW STEM AUGER

BORING NUMBER: 407PZ01

BORING DEPTH (ft): 42

BORING DIAMETER (in): 8

WELL DEPTH (ft):

WELL DIAMETER (in):

REFERENCE ELEVATION (ft): 201.31

CASING STICKUP (in): 0

FIELD PARTY: P. Ribbens

SCREEN LENGTH (ft):

SCREEN TYPE:

SLOT SIZE (in):

FILTER PACK:

DATE STARTED: 6/17/96

DATE COMPLETED: 6/17/96

NORTHING: 2653327.4

EASTING: 1674652.5

DEPTH feet	LENGTH RECOVERY	SAMP. NO.	SAMP. TYP.	BLOWS/FT.	PID (ppm)	GRAPHIC LOG	SOIL CLASS	DESCRIPTION AND REMARKS	WELL DIAGRAM
0							GW	Asphalt surface	
5			SS	33	0.3		GW	Gray-brown SANDY GRAVEL (GW), with silt, dense, dry, no odor.	
10			SS	26	1.6		GW	Gray-brown SANDY GRAVEL (GW), clast supported, gravel and broken cobbles to 65-70mm, medium dense, dry to damp, no odor.	
15			SS	41	2.4		GW	Lithology same as above, gray-green color, ravel and sand well graded, dense, damp to moist.	
20							SW		

BORING LOG

BORING NUMBER: 407PZ01

CLIENT: US AIR FORCE
 PROJECT NAME: SERA IV
 SITE: ST407
 JOB NUMBER: 9000-068
 LOGGED BY: P. Moore APPROVED BY: P. Ribbens
 DRILLED BY: Hughes Drilling
 METHOD: 4.25 in. HOLLOW STEM AUGER

BORING DEPTH (ft): 42
 BORING DIAMETER (in): 8
 WELL DEPTH (ft):
 WELL DIAMETER (in):
 REFERENCE ELEVATION (ft): 201.31
 CASING STICKUP (in): 0
 FIELD PARTY: P. Ribbens
 SCREEN LENGTH (ft):
 SCREEN TYPE:
 SLOT SIZE (in):
 FILTER PACK:
 DATE STARTED: 6/17/96
 DATE COMPLETED: 6/17/96
 NORTHING: 2653327.4
 EASTING: 1674652.5

DEPTH feet	LENGTH RECOVERY	SAMP. NO.	SAMP. TYP.	BLOWS/FT.	PID (ppm)	GRAPHIC LOG	SOIL CLASS	DESCRIPTION AND REMARKS	WELL DIAGRA
23			SS	29	1.6		SW	Olive green SAND (SW), with gravel, well graded, trace coal, moist, changing to..	
27							GW	GRAVEL (GW), well graded, with broken cobbles, medium dense.	
29			SS	39	1.7		SW	Green SAND (SW), with gravel and broken cobbles (gray), matrix supported, several coal lenses in sample, dry to damp.	
31			SS	39	2.8		GW	Green-gray SANDY GRAVEL (GW), well graded, clast supported, gravel smaller 20-30mm, few cobbles, dense, damp, iron oxide stain and coal in the sampler shoe.	
35		407PZ01 ISO36. ON	SS	28	3.8		SW	Green-brown GRAVELLY SAND (SW), 15% small gravel (<20mm), 5 inch lense of beach sand (SP), trace silt, medium dense, damp, no odor.	

PIEZOMETER DIAGRAM

BORING NUMBER: 407PZ01

CLIENT: U.S. AIR FORCE

BORING DEPTH (ft): 43'

SCREEN LENGTH (ft):

PROJECT NAME: SERA IV

BORING DIAMETER (in): 8

SCREEN TYPE:

SITE: ST407

WELL DEPTH (ft):

SLOT SIZE (in):

JOB NUMBER: 9000-068

WELL DIAMETER (in):

FILTER PACK:

LOGGED BY: P. MOORE APPROVED BY: P. RIBBENS

REFERENCE ELEVATION (ft): 201.31

DATE STARTED: 6/17/96

DRILLED BY: HUGHES DRILLING

CASING STICKUP (in): 0

DATE COMPLETED: 6/17/96

METHOD: 4.25 IN. HOLLOW STEM AUGER

FIELD PARTY: D. McGEE

NORTHING: 2653327.4

EASTING: 1674652.5

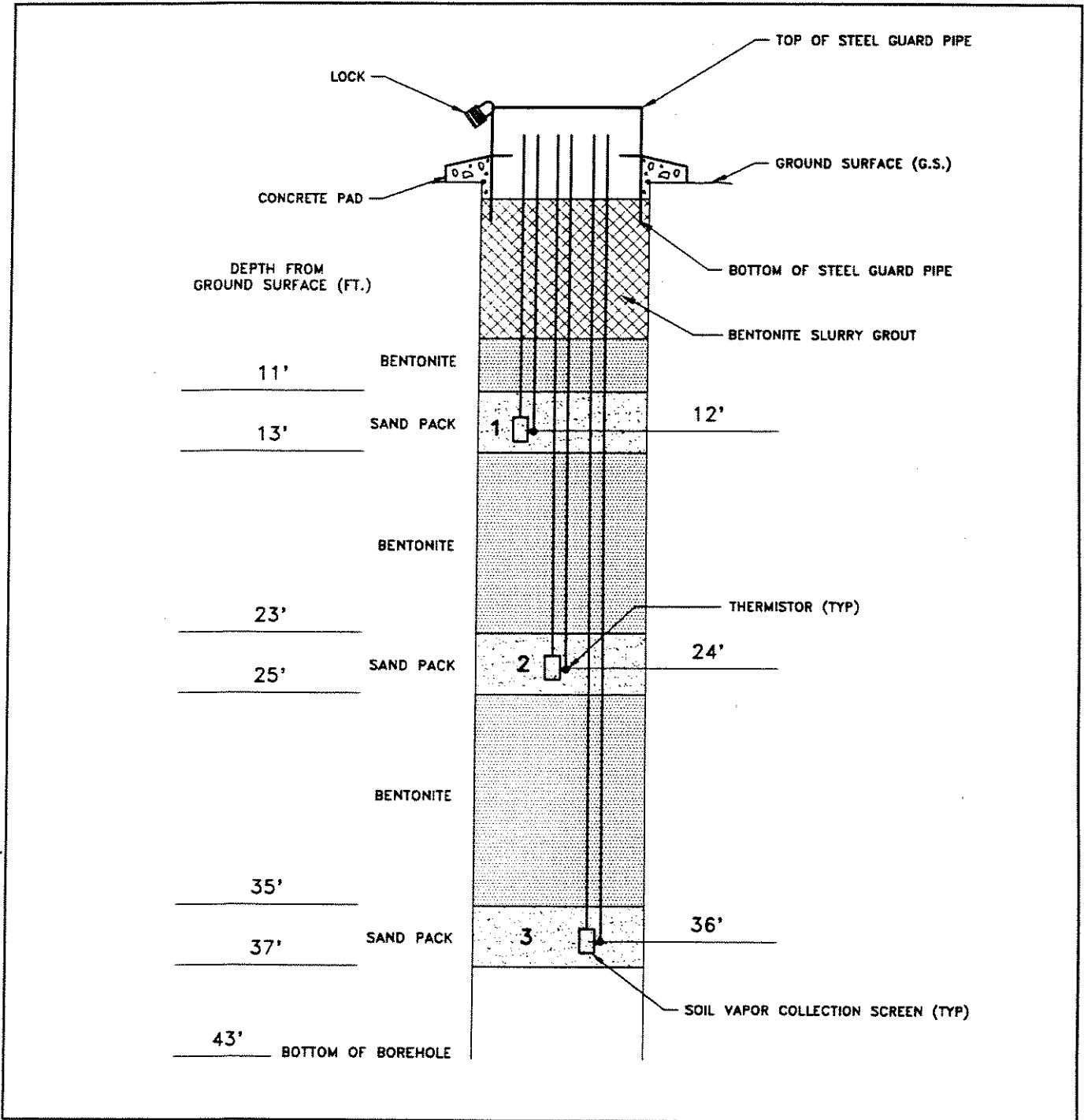

BORING LOG

BORING NUMBER: 407PZ02

CLIENT: US AIR FORCE

BORING DEPTH (ft): 42

SCREEN LENGTH (ft):

PROJECT NAME: SERA IV

BORING DIAMETER (in): 8

SCREEN TYPE:

SITE: ST407

WELL DEPTH (ft):

SLOT SIZE (in):

JOB NUMBER: 9000-068

WELL DIAMETER (in):

FILTER PACK:

LOGGED BY: P. Moore APPROVED BY: P. Ribbens

REFERENCE ELEVATION (ft): 199.99 DATE STARTED: 6/18/96

DRILLED BY: Hughes Drilling

CASING STICKUP (in): 0

DATE COMPLETED: 6/18/96

METHOD: 4.25 in. HOLLOW STEM AUGER

FIELD PARTY: P. Ribbens

NORTHING: 2653408.5

EASTING: 1674697.9

DEPTH feet	LENGTH RECOVERY	SAMP. NO.	SAMP. TYP.	BLOWS/FT.	PID (ppm)	GRAPHIC LOG	SOIL CLASS	DESCRIPTION AND REMARKS	WELL DIAGRA
20		407PZ02 2S021 ON	SS	42	4.6		GW	Medium brown SANDY GRAVEL (GW), well graded, clast supported (iron oxide staining), broken cobbles, dense, damp, odor at 20 feet not at 22 feet.	
25			SS	34	2.2			SANDY GRAVEL (GW), broken cobbles, few fines, iron oxide staining on sand, dense, no hydrocarbon odor.	
30			SS	35	0.4		SW	GRAVELLY SAND (SW), well graded, few fines, trace silt and coal, dense, damp to moist.	
35		407PZ02 2S036. ON	SS	24	0.0			Lithology same as above, light gray-brown, damp to moist, slight hydrocarbon odor in sleeve at 36.5 feet no odor in shoe.	
40							GW		

BORING LOG

BORING NUMBER: 407PZ02

CLIENT: US AIR FORCE

BORING DEPTH (ft): 42

SCREEN LENGTH (ft):

PROJECT NAME: SERA IV

BORING DIAMETER (in): 8

SCREEN TYPE:

SITE: ST407

WELL DEPTH (ft):

SLOT SIZE (in):

JOB NUMBER: 9000-088

WELL DIAMETER (in):

FILTER PACK:

LOGGED BY: P. Moore APPROVED BY: P. Ribbens

REFERENCE ELEVATION (ft): 199.99

DATE STARTED: 6/18/96

DRILLED BY: Hughes Drilling

CASING STICKUP (in): 0

DATE COMPLETED: 6/18/96

METHOD: 4.25 in. HOLLOW STEM AUGER

FIELD PARTY: P. Ribbens

NORTHING: 2653408.5

EASTING: 1674697.9

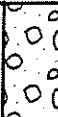
DEPTH feet	LENGTH	RECOVERY	SAMP. NO.	SAMP. TYP.	BLOWS/FT.	PID (ppm)	GRAPHIC LOG	SOIL CLASS	DESCRIPTION AND REMARKS	WELL DIAGRAM
42				SS	27	0.3		GW	SANDY GRAVEL (GW), gravels to cobbles, coal abundant, medium dense, moist to saturated, capillary fringe.	
42									End of boring at 42 feet. Boring completed as a piezometer.	

PIEZOMETER DIAGRAM

BORING NUMBER: 407PZ02

CLIENT: U.S. AIR FORCE

BORING DEPTH (ft): 42'

SCREEN LENGTH (ft):

PROJECT NAME: SERA IV

BORING DIAMETER (in): 8

SCREEN TYPE:

SITE: ST407

WELL DEPTH (ft):

SLOT SIZE (in):

JOB NUMBER: 9000-068

WELL DIAMETER (in):

FILTER PACK:

LOGGED BY: P. MOORE APPROVED BY: P. RIBBENS

REFERENCE ELEVATION (ft): 199.99 DATE STARTED: 6/18/96

DRILLED BY: HUGHES DRILLING

CASING STICKUP (in): 0

DATE COMPLETED: 6/18/96

METHOD: 4.25 IN. HOLLOW STEM AUGER

FIELD PARTY: D. McGEE

NORTHING: 2653408.5

EASTING: 1674697.9

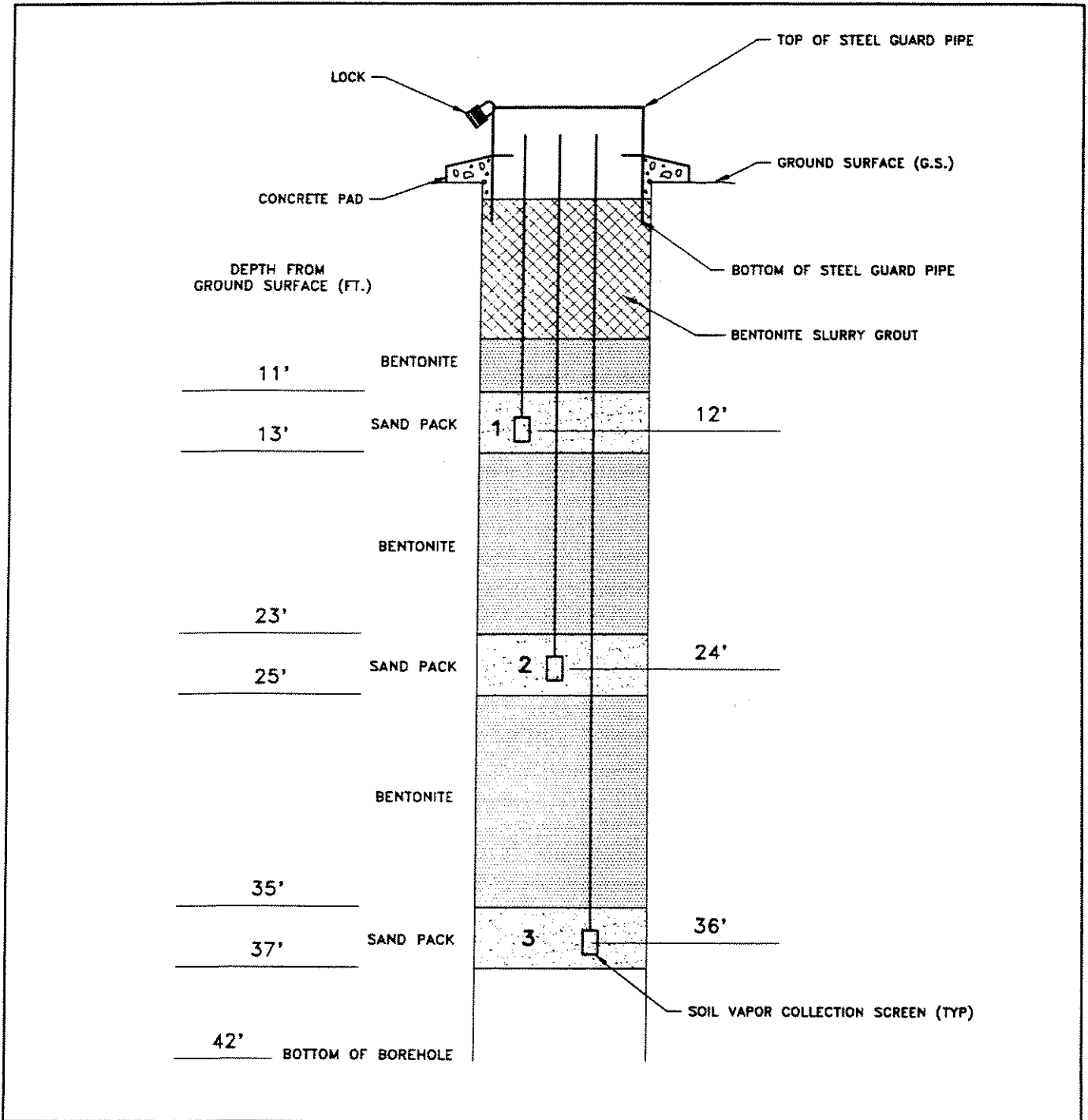

BORING LOG

BORING NUMBER: 407PZ03

CLIENT: US AIR FORCE

BORING DEPTH (ft): 45

SCREEN LENGTH (ft):

PROJECT NAME: SERA IV

BORING DIAMETER (in): 8

SCREEN TYPE:

SITE: ST407

WELL DEPTH (ft):

SLOT SIZE (in):

JOB NUMBER: 9000-068

WELL DIAMETER (in):

FILTER PACK:

LOGGED BY: P. Moore APPROVED BY: P. Ribbens

REFERENCE ELEVATION (ft): 200.81 DATE STARTED: 6/18/96

DRILLED BY: Hughes Drilling

CASING STICKUP (in): 0

DATE COMPLETED: 6/18/96

METHOD: 4.25 in. HOLLOW STEM AUGER

FIELD PARTY: P. Ribbens

NORTHING: 2653272.4

EASTING: 1674697.4

DEPTH feet	LENGTH RECOVERY	SAMP. NO.	SAMP. TYP.	BLOWS/FT.	PID (ppm)	GRAPHIC LOG	SOIL CLASS	DESCRIPTION AND REMARKS	WELL DIAGRA
25			SS	44	1.6		SW	SAND (SW), well graded, with gravel and broken cobbles (40%), close to a silty sand (large % of fines), dense, dry.	
30			SS	42	1.5		GW	SANDY GRAVEL (GW), well graded, angular gravel to 30-40mm, few fines, iron oxide stained weathered clasts of gravel, dense, damp, no hydrocarbon odor.	
35			SS	39	0.3		SW	Light gray-brown GRAVELLY SAND (SW), well graded sand, trace silt, dense, damp, no hydrocarbon odor.	
40			SS	38	0.0		GW	Gray-brown SANDY GRAVEL (GW), subangular gravel to 40mm, trace silt, damp, no hydrocarbon odor.	
							SW		

BORING LOG

CLIENT: US AIR FORCE

PROJECT NAME: SERA IV

SITE: ST407

JOB NUMBER: 9000-068

LOGGED BY: P. Moore APPROVED BY: P. Ribbens

DRILLED BY: Hughes Drilling

METHOD: 4.25 in. HOLLOW STEM AUGER

BORING NUMBER: 407PZ03

BORING DEPTH (ft): 45

BORING DIAMETER (in): 8

WELL DEPTH (ft):

WELL DIAMETER (in):

REFERENCE ELEVATION (ft): 200.81

CASING STICKUP (in): 0

FIELD PARTY: P. Ribbens

SCREEN LENGTH (ft):

SCREEN TYPE:

SLOT SIZE (in):

FILTER PACK:

DATE STARTED: 6/18/96

DATE COMPLETED: 6/18/96

NORTHING: 2653272.4

EASTING: 1674697.4

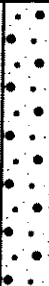
DEPTH feet	LENGTH RECOVERY	SAMP. NO.	SAMP. TYP.	BLOWS/FT.	PID (ppm)	GRAPHIC LOG	SOIL CLASS	DESCRIPTION AND REMARKS	WELL DIAGRAM
45		407PZ03 3S041 ON	SS	28	0.0		SW	GRAVELLY SAND (SW), trace fines, abundant coal, medium dense, damp.	
								End of boring at 45 feet. Boring completed as a piezometer.	

PIEZOMETER DIAGRAM

BORING NUMBER: 407PZ03

CLIENT: U.S. AIR FORCE

BORING DEPTH (ft): 45'

SCREEN LENGTH (ft):

PROJECT NAME: SERA IV

BORING DIAMETER (in): 8

SCREEN TYPE:

SITE: ST407

WELL DEPTH (ft):

SLOT SIZE (in):

JOB NUMBER: 9000-068

WELL DIAMETER (in):

FILTER PACK:

LOGGED BY: P. MOORE APPROVED BY: P. RIBBENS

REFERENCE ELEVATION (ft): 200.81

DATE STARTED: 6/18/96

DRILLED BY: HUGHES DRILLING

CASING STICKUP (in): 0

DATE COMPLETED: 6/18/96

METHOD: 4.25 IN. HOLLOW STEM AUGER

FIELD PARTY: D. McGEE

NORTHING: 2653272.4

EASTING: 1674697.4

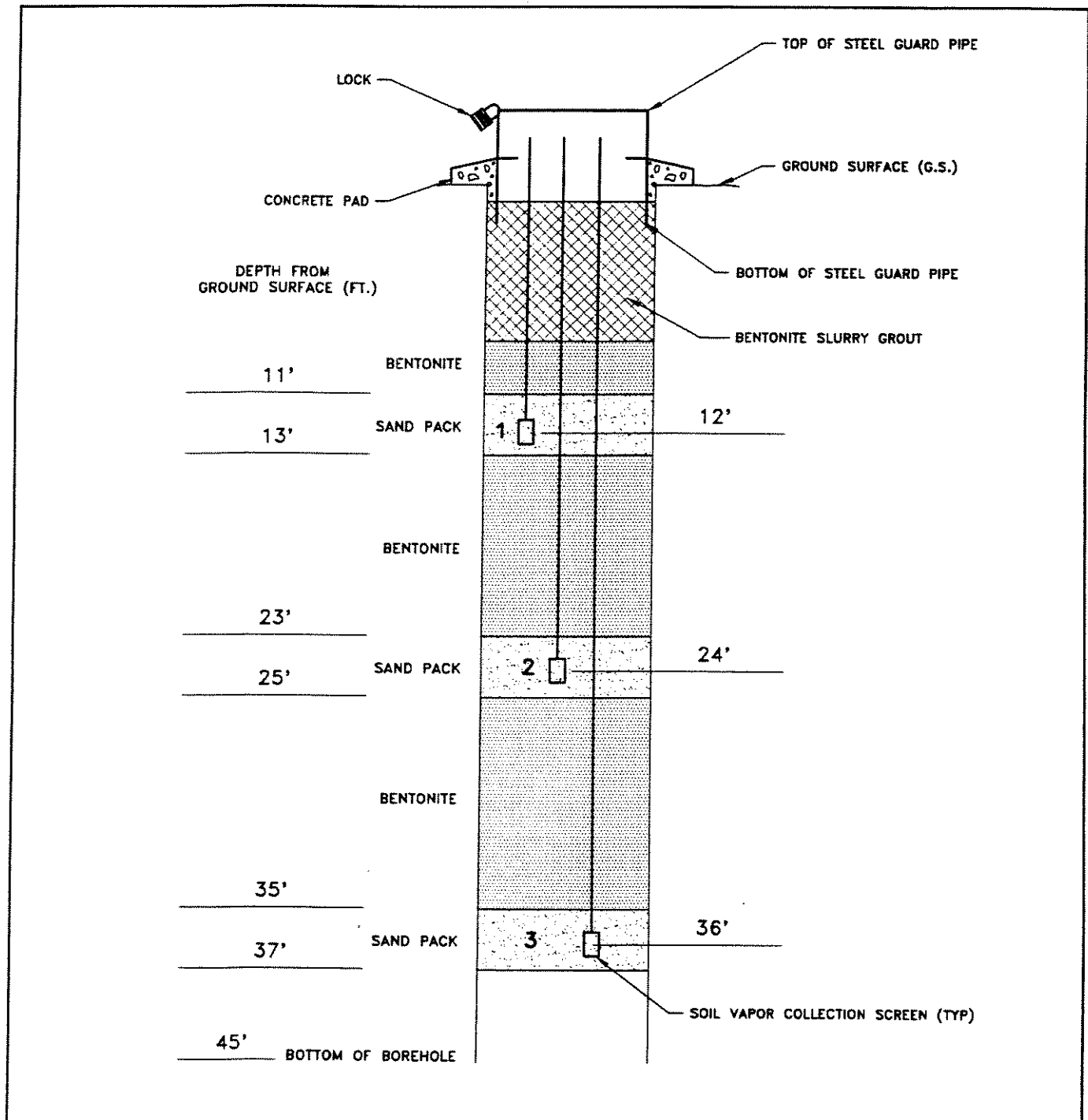

BORING LOG

CLIENT: US AIR FORCE

PROJECT NAME: SERA IV

SITE: ST407

JOB NUMBER: 9000-068

LOGGED BY: P. Moore APPROVED BY: P. Ribbens

DRILLED BY: Hughes Drilling

METHOD: 4.25 in. HOLLOW STEM AUGER

BORING NUMBER: 407PZ04

BORING DEPTH (ft): 43

BORING DIAMETER (in): 8

WELL DEPTH (ft):

WELL DIAMETER (in):

REFERENCE ELEVATION (ft): 201.24

CASING STICKUP (in): 0

FIELD PARTY: P. Ribbens

SCREEN LENGTH (ft):

SCREEN TYPE:

SLOT SIZE (in):

FILTER PACK:

DATE STARTED: 6/19/96

DATE COMPLETED: 6/19/96

NORTHING: 2653270.1

EASTING: 1674659.1

DEPTH feet	LENGTH RECOVERY	SAMP. NO.	SAMP. TYP.	BLOWS/FT.	PID (ppm)	GRAPHIC LOG	SOIL CLASS	DESCRIPTION AND REMARKS	WELL DIAGRAM
0							GW	Asphalt surface (6 inches).	
5			SS	33	0.0		GW	Light gray-brown SANDY GRAVEL (GW), angular gravel to 35mm with broken cobbles, well graded sand, trace silt, dense, damp.	
10			SS	34	0.0		GW	Lithology same as above, trace iron oxide staining, cobble in shoe.	
15		407PZ04 4S018. ON	SS	27	1.4		SW	Light brown-green GRAVELLY SAND (SW), well graded sand, few fines, coal present, medium dense, damp to moist.	
20							GW		

PIEZOMETER DIAGRAM

BORING NUMBER: 407PZ04

CLIENT: U.S. AIR FORCE

BORING DEPTH (ft): 43'

SCREEN LENGTH (ft):

PROJECT NAME: SERA IV

BORING DIAMETER (in): 8

SCREEN TYPE:

SITE: ST407

WELL DEPTH (ft):

SLOT SIZE (in):

JOB NUMBER: 9000-068

WELL DIAMETER (in):

FILTER PACK:

LOGGED BY: P. MOORE APPROVED BY: P. RIBBENS

REFERENCE ELEVATION (ft): 201.24

DATE STARTED: 6/19/96

DRILLED BY: HUGHES DRILLING

CASING STICKUP (in): 0

DATE COMPLETED: 6/19/96

METHOD: 4.25 IN. HOLLOW STEM AUGER

FIELD PARTY: D. McGEE

NORTHING: 2653270.1

EASTING: 1674659.1

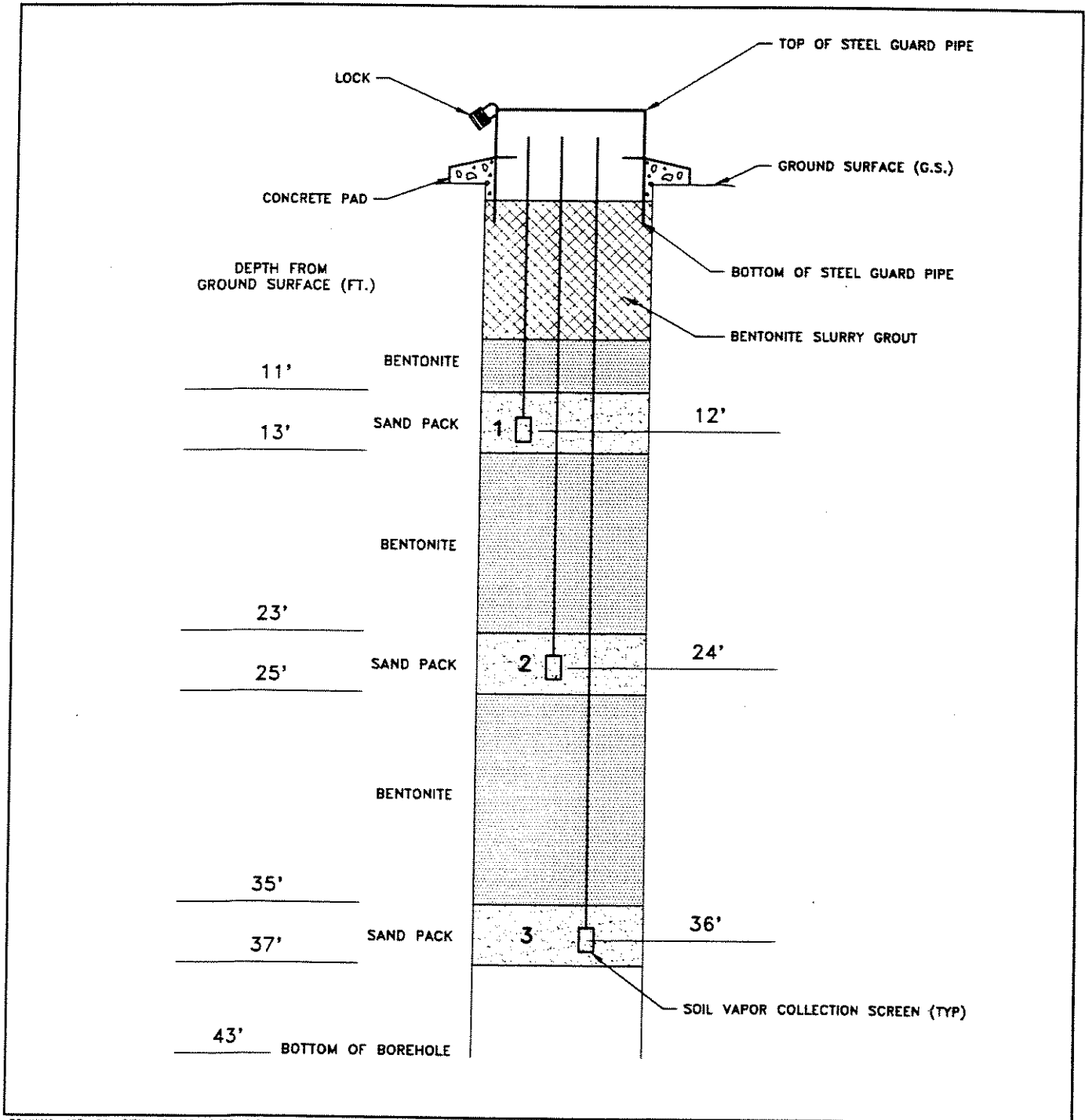

BORING LOG

CLIENT: US AIR FORCE
 PROJECT NAME: SERA IV
 SITE: ST407
 JOB NUMBER: 9000-068
 LOGGED BY: P. Moore APPROVED BY: P. Ribbens
 DRILLED BY: Hughes Drilling
 METHOD: 4.25 in. HOLLOW STEM AUGER

BORING NUMBER: 407WL01

BORING DEPTH (ft): 47
 BORING DIAMETER (in): 8
 WELL DEPTH (ft): 40.25
 WELL DIAMETER (in): 2
 REFERENCE ELEVATION (ft): 200.40
 CASING STICKUP (in): 0
 FIELD PARTY: D. McGee

SCREEN LENGTH (ft): 10
 SCREEN TYPE: Slotted PVC
 SLOT SIZE (in): 0.020
 FILTER PACK: 10-20 Colorado Sand
 DATE STARTED: 6/17/96
 DATE COMPLETED: 6/17/96
 NORTHING: 2653318.3
 EASTING: 1674696.5

DEPTH feet	LENGTH RECOVERY	SAMP. NO.	SAMP. TYP.	BLOWS/FT.	PID (ppm)	GRAPHIC LOG	SOIL CLASS	DESCRIPTION AND REMARKS	WELL DIAGRAM
25			SS	37	192		GW	Gray-green SANDY GRAVEL (GW), well graded, subrounded gravel, trace silt, iron oxide clasts, hydrocarbon odor. Soil Classification at 20.5 feet: Gravel 64.6% Sand 29.9% Silt 5.5%	<p>2" Sch. 40 PVC</p> <p>2" PVC 0.020" Slotted Screen</p> <p>#10-20 Colorado Silica Sand</p> <p>Volclay Grout</p> <p>Bent</p>
30			SS	33	34.7		GW	SANDY GRAVEL (GW), subangular gravel to 40mm - predominantly <20mm, medium to coarse sand, moist to wet, slight odor.	
35			SS	38	30.4		SW	Olive green-brown SAND (SW), with gravel, little fines, trace iron oxide, dense, damp, some odor.	
40			SS	38	33.8		GW	Lithology same as above, coal, odor possibly hydrocarbon	

APPENDIX C
ANALYTICAL DATA

AFIDs 575, 576 and 578

ST407

SITE ST407
SOIL CONTAMINANT ANALYTICAL RESULTS

SAMPLE ID	LAB ID	MATRIX	ANALYSIS	PARAMETER	RESULT	UNITS	MRL	MDL	DIL	DATE
407BH01SO26.0N	A96030805	SO	AK101	GRO	5 U	MG/KG	5	0.3	1	6/19/96
407BH01SO26.0N	A96030805	SO	AK102	DRO	10 U	MG/KG	10	5	1	6/19/96
407BH01SO26.0N	A96030805	SO	AK103	RRO	40 U	MG/KG	40	20	1	6/19/96
407BH01SO26.0N	A96030805	SO	E160.3M	Solids, Percent	94.4	PERCENT	0	0	1	6/19/96
407BH01SO26.0N	A96030805	SO	SW8020A	Benzene	0.05 U	MG/KG	0.05	0.01	1	6/19/96
407BH01SO26.0N	A96030805	SO	SW8020A	Ethylbenzene	0.05 U	MG/KG	0.05	0.01	1	6/19/96
407BH01SO26.0N	A96030805	SO	SW8020A	Toluene	0.05 U	MG/KG	0.05	0.01	1	6/19/96
407BH01SO26.0N	A96030805	SO	SW8020A	Xylenes	0.05 U	MG/KG	0.05	0.03	1	6/19/96
407BH01SO26.0N DUP	A96030807	SO	AK101	GRO	5 U	MG/KG	5	0.3	1	6/19/96
407BH01SO26.0N DUP	A96030807	SO	AK102	DRO	10 U	MG/KG	10	5	1	6/19/96
407BH01SO26.0N DUP	A96030807	SO	AK103	RRO	40 U	MG/KG	40	20	1	6/19/96
407BH01SO26.0N DUP	A96030807	SO	E160.3M	Solids, Percent	96.3	PERCENT	0	0	1	6/19/96
407BH01SO26.0N DUP	A96030807	SO	SW8020A	Benzene	0.05 U	MG/KG	0.05	0.01	1	6/19/96
407BH01SO26.0N DUP	A96030807	SO	SW8020A	Ethylbenzene	0.05 U	MG/KG	0.05	0.01	1	6/19/96
407BH01SO26.0N DUP	A96030807	SO	SW8020A	Toluene	0.05 U	MG/KG	0.05	0.01	1	6/19/96
407BH01SO26.0N DUP	A96030807	SO	SW8020A	Xylenes	0.05 U	MG/KG	0.05	0.03	1	6/19/96
407BH01SO36.0N	A96030806	SO	AK101	GRO	5 U	MG/KG	5	0.3	1	6/19/96
407BH01SO36.0N	A96030806	SO	AK102	DRO	10 U	MG/KG	10	5	1	6/19/96
407BH01SO36.0N	A96030806	SO	AK103	RRO	40 U	MG/KG	40	20	1	6/19/96
407BH01SO36.0N	A96030806	SO	E160.3M	Solids, Percent	96.2	PERCENT	0	0	1	6/19/96
407BH01SO36.0N	A96030806	SO	SW8020A	Benzene	0.05 U	MG/KG	0.05	0.01	1	6/19/96
407BH01SO36.0N	A96030806	SO	SW8020A	Ethylbenzene	0.05 U	MG/KG	0.05	0.01	1	6/19/96
407BH01SO36.0N	A96030806	SO	SW8020A	Toluene	0.05 U	MG/KG	0.05	0.01	1	6/19/96
407BH01SO36.0N	A96030806	SO	SW8020A	Xylenes	0.05 U	MG/KG	0.05	0.03	1	6/19/96
407EB	A96029709	W	AK101	GRO	50 U	UG/L	50	5	1	6/17/96
407EB	A96029709	W	SW8020A	Benzene	0.5 U	UG/L	0.5	0.2	1	6/17/96
407EB	A96029709	W	SW8020A	Ethylbenzene	1 U	UG/L	1	0.2	1	6/17/96
407EB	A96029709	W	SW8020A	Toluene	1 U	UG/L	1	0.2	1	6/17/96
407EB	A96029709	W	SW8020A	Xylenes	1 U	UG/L	1	0.4	1	6/17/96
407PZ01SO36.0N	A96029701	SO	AK101	GRO	5 U	MG/KG	5	0.3	1	6/17/96
407PZ01SO36.0N	A96029701	SO	AK102	DRO	28	MG/KG	10	5	1	6/17/96
407PZ01SO36.0N	A96029701	SO	AK103	RRO	40 U	MG/KG	40	20	1	6/17/96
407PZ01SO36.0N	A96029701	SO	E160.3M	Solids, Percent	96.3	PERCENT	0	0	1	6/17/96
407PZ01SO36.0N	A96029701	SO	SW8020A	Benzene	0.05 U	MG/KG	0.05	0.01	1	6/17/96
407PZ01SO36.0N	A96029701	SO	SW8020A	Ethylbenzene	0.05 U	MG/KG	0.05	0.01	1	6/17/96
407PZ01SO36.0N	A96029701	SO	SW8020A	Toluene	0.05 U	MG/KG	0.05	0.01	1	6/17/96
407PZ01SO36.0N	A96029701	SO	SW8020A	Xylenes	0.05 U	MG/KG	0.05	0.03	1	6/17/96
407PZ01SO41.0N	A96029702	SO	AK101	GRO	5 U	MG/KG	5	0.3	1	6/17/96
407PZ01SO41.0N	A96029702	SO	AK102	DRO	13	MG/KG	10	5	1	6/17/96
407PZ01SO41.0N	A96029702	SO	AK103	RRO	40 U	MG/KG	40	20	1	6/17/96
407PZ01SO41.0N	A96029702	SO	E160.3M	Solids, Percent	97.7	PERCENT	0	0	1	6/17/96
407PZ01SO41.0N	A96029702	SO	SW8020A	Benzene	0.05 U	MG/KG	0.05	0.01	1	6/17/96
407PZ01SO41.0N	A96029702	SO	SW8020A	Ethylbenzene	0.05 U	MG/KG	0.05	0.01	1	6/17/96
407PZ01SO41.0N	A96029702	SO	SW8020A	Toluene	0.05 U	MG/KG	0.05	0.01	1	6/17/96
407PZ01SO41.0N	A96029702	SO	SW8020A	Xylenes	0.05 U	MG/KG	0.05	0.03	1	6/17/96
407PZ02SO21.0N	A96030301	SO	AK101	GRO	5 U	MG/KG	5	0.3	1	6/18/96
407PZ02SO21.0N	A96030301	SO	AK102	DRO	10 U	MG/KG	10	5	1	6/18/96
407PZ02SO21.0N	A96030301	SO	AK103	RRO	40 U	MG/KG	40	20	1	6/18/96
407PZ02SO21.0N	A96030301	SO	E160.3M	Solids, Percent	90.5	PERCENT	0	0	1	6/18/96
407PZ02SO21.0N	A96030301	SO	SW8020A	Benzene	0.05 U	MG/KG	0.05	0.01	1	6/18/96
407PZ02SO21.0N	A96030301	SO	SW8020A	Ethylbenzene	0.05 U	MG/KG	0.05	0.01	1	6/18/96
407PZ02SO21.0N	A96030301	SO	SW8020A	Toluene	0.05 U	MG/KG	0.05	0.01	1	6/18/96
407PZ02SO21.0N	A96030301	SO	SW8020A	Xylenes	0.05 U	MG/KG	0.05	0.03	1	6/18/96
407PZ02SO36.0N	A96030302	SO	AK101	GRO	5 U	MG/KG	5	0.3	1	6/18/96
407PZ02SO36.0N	A96030302	SO	AK102	DRO	10 U	MG/KG	10	5	1	6/18/96
407PZ02SO36.0N	A96030302	SO	AK103	RRO	40 U	MG/KG	40	20	1	6/18/96
407PZ02SO36.0N	A96030302	SO	E160.3M	Solids, Percent	96.6	PERCENT	0	0	1	6/18/96
407PZ02SO36.0N	A96030302	SO	SW8020A	Benzene	0.05 U	MG/KG	0.05	0.01	1	6/18/96
407PZ02SO36.0N	A96030302	SO	SW8020A	Ethylbenzene	0.05 U	MG/KG	0.05	0.01	1	6/18/96
407PZ02SO36.0N	A96030302	SO	SW8020A	Toluene	0.05 U	MG/KG	0.05	0.01	1	6/18/96
407PZ02SO36.0N	A96030302	SO	SW8020A	Xylenes	0.05 U	MG/KG	0.05	0.03	1	6/18/96

NOTES:
MRL = Method Reporting Limit
MDL = Method Detection Limit
U = Not-detected at MRL
B = Analyte detected in associated blank
J = Value considered an estimate value.
Dil = Dilution.

SITE ST407
SOIL CONTAMINANT ANALYTICAL RESULTS

SAMPLE ID	LAB ID	MATRIX	ANALYSIS	PARAMETER	RESULT	UNITS	MRL	MDL	DIL	DATE	
407PZ03SO41.0N	A96030306	SO	AK101	GRO	5	U	MG/KG	5	0.3	1	6/18/96
407PZ03SO41.0N	A96030306	SO	AK102	DRO	280		MG/KG	10	5	1	6/18/96
407PZ03SO41.0N	A96030306	SO	AK103	RRO	180		MG/KG	40	20	1	6/18/96
407PZ03SO41.0N	A96030306	SO	E160.3M	Solids, Percent	80.1		PERCENT	0	0	1	6/18/96
407PZ03SO41.0N	A96030306	SO	SW8020A	Benzene	0.05	U	MG/KG	0.05	0.01	1	6/18/96
407PZ03SO41.0N	A96030306	SO	SW8020A	Ethylbenzene	0.05	U	MG/KG	0.05	0.01	1	6/18/96
407PZ03SO41.0N	A96030306	SO	SW8020A	Toluene	0.05	U	MG/KG	0.05	0.01	1	6/18/96
407PZ03SO41.0N	A96030306	SO	SW8020A	Xylenes	0.05	U	MG/KG	0.05	0.03	1	6/18/96
407PZ03SO6.0N	A96030305	SO	AK101	GRO	5	U	MG/KG	5	0.3	1	6/18/96
407PZ03SO6.0N	A96030305	SO	AK102	DRO	10	U	MG/KG	10	5	1	6/18/96
407PZ03SO6.0N	A96030305	SO	AK103	RRO	40	U	MG/KG	40	20	1	6/18/96
407PZ03SO6.0N	A96030305	SO	E160.3M	Solids, Percent	97.2		PERCENT	0	0	1	6/18/96
407PZ03SO6.0N	A96030305	SO	SW8020A	Benzene	0.05	U	MG/KG	0.05	0.01	1	6/18/96
407PZ03SO6.0N	A96030305	SO	SW8020A	Ethylbenzene	0.05	U	MG/KG	0.05	0.01	1	6/18/96
407PZ03SO6.0N	A96030305	SO	SW8020A	Toluene	0.05	U	MG/KG	0.05	0.01	1	6/18/96
407PZ03SO6.0N	A96030305	SO	SW8020A	Xylenes	0.05	U	MG/KG	0.05	0.03	1	6/18/96
407PZ04SO16.0N	A96030801	SO	AK101	GRO	5	U	MG/KG	5	0.3	1	6/19/96
407PZ04SO16.0N	A96030801	SO	AK102	DRO	10	U	MG/KG	10	5	1	6/19/96
407PZ04SO16.0N	A96030801	SO	AK103	RRO	40	U	MG/KG	40	20	1	6/19/96
407PZ04SO16.0N	A96030801	SO	E160.3M	Solids, Percent	96.9		PERCENT	0	0	1	6/19/96
407PZ04SO16.0N	A96030801	SO	SW8020A	Benzene	0.05	U	MG/KG	0.05	0.01	1	6/19/96
407PZ04SO16.0N	A96030801	SO	SW8020A	Ethylbenzene	0.05	U	MG/KG	0.05	0.01	1	6/19/96
407PZ04SO16.0N	A96030801	SO	SW8020A	Toluene	0.05	U	MG/KG	0.05	0.01	1	6/19/96
407PZ04SO16.0N	A96030801	SO	SW8020A	Xylenes	0.05	U	MG/KG	0.05	0.03	1	6/19/96
407PZ04SO41.0N	A96030802	SO	AK101	GRO	5	U	MG/KG	5	0.3	1	6/19/96
407PZ04SO41.0N	A96030802	SO	AK102	DRO	28		MG/KG	10	5	1	6/19/96
407PZ04SO41.0N	A96030802	SO	AK103	RRO	40	U	MG/KG	40	20	1	6/19/96
407PZ04SO41.0N	A96030802	SO	E160.3M	Solids, Percent	95.9		PERCENT	0	0	1	6/19/96
407PZ04SO41.0N	A96030802	SO	SW8020A	Benzene	0.02	J	MG/KG	0.05	0.01	1	6/19/96
407PZ04SO41.0N	A96030802	SO	SW8020A	Ethylbenzene	0.05	U	MG/KG	0.05	0.01	1	6/19/96
407PZ04SO41.0N	A96030802	SO	SW8020A	Toluene	0.07	J	MG/KG	0.05	0.01	1	6/19/96
407PZ04SO41.0N	A96030802	SO	SW8020A	Xylenes	0.05	U	MG/KG	0.05	0.03	1	6/19/96
407WL01SO16.0N	A96029703	SO	AK101	GRO	233		MG/KG	5	0.3	1	6/17/96
407WL01SO16.0N	A96029703	SO	AK102	DRO	1400		MG/KG	10	5	1	6/17/96
407WL01SO16.0N	A96029703	SO	AK103	RRO	300		MG/KG	40	20	1	6/17/96
407WL01SO16.0N	A96029703	SO	E160.3M	Solids, Percent	95.9		PERCENT	0	0	1	6/17/96
407WL01SO16.0N	A96029703	SO	SW8020A	Benzene	0.05	U	MG/KG	0.05	0.01	1	6/17/96
407WL01SO16.0N	A96029703	SO	SW8020A	Ethylbenzene	0.8		MG/KG	0.05	0.01	1	6/17/96
407WL01SO16.0N	A96029703	SO	SW8020A	Toluene	0.6		MG/KG	0.05	0.01	1	6/17/96
407WL01SO16.0N	A96029703	SO	SW8020A	Xylenes	2.15		MG/KG	0.05	0.03	1	6/17/96
407WL01SO16.0N DUP	A96029705	SO	AK101	GRO	257		MG/KG	5	0.3	1	6/17/96
407WL01SO16.0N DUP	A96029705	SO	AK102	DRO	2600		MG/KG	10	5	1	6/17/96
407WL01SO16.0N DUP	A96029705	SO	AK103	RRO	450		MG/KG	40	20	1	6/17/96
407WL01SO16.0N DUP	A96029705	SO	E160.3M	Solids, Percent	95.5		PERCENT	0	0	1	6/17/96
407WL01SO16.0N DUP	A96029705	SO	SW8020A	Benzene	0.15		MG/KG	0.05	0.01	1	6/17/96
407WL01SO16.0N DUP	A96029705	SO	SW8020A	Ethylbenzene	0.89		MG/KG	0.05	0.01	1	6/17/96
407WL01SO16.0N DUP	A96029705	SO	SW8020A	Toluene	0.05	U	MG/KG	0.05	0.01	1	6/17/96
407WL01SO16.0N DUP	A96029705	SO	SW8020A	Xylenes	2.22		MG/KG	0.05	0.03	1	6/17/96
407WL01SO41.0N	A96029704	SO	AK101	GRO	151		MG/KG	5	0.3	1	6/17/96
407WL01SO41.0N	A96029704	SO	AK102	DRO	1800		MG/KG	10	5	1	6/17/96
407WL01SO41.0N	A96029704	SO	AK103	RRO	55		MG/KG	40	20	1	6/17/96
407WL01SO41.0N	A96029704	SO	E160.3M	Solids, Percent	98.1		PERCENT	0	0	1	6/17/96
407WL01SO41.0N	A96029704	SO	SW8020A	Benzene	0.05	U	MG/KG	0.05	0.01	1	6/17/96
407WL01SO41.0N	A96029704	SO	SW8020A	Ethylbenzene	0.7		MG/KG	0.05	0.01	1	6/17/96
407WL01SO41.0N	A96029704	SO	SW8020A	Toluene	0.05	U	MG/KG	0.05	0.01	1	6/17/96
407WL01SO41.0N	A96029704	SO	SW8020A	Xylenes	0.52		MG/KG	0.05	0.03	1	6/17/96

NOTES:
MRL = Method Reporting Limit.
MDL = Method Detection Limit.
U = Not-detected at MRL.
B = Analyte detected in associated blank.
J = Value considered an estimate value.
Dil = Dilution.

SITE ST407
SOIL NUTRIENT ANALYTICAL DATA RESULTS

Sample ID	Lab ID	Matrix	Analysis	Parameter	Result	Units	MRL	MDL	Dil
407WL01SO16.0N	A96029703	SO	350.3	Ammonium	0.5 U	mg/Kg	0.5	0.4	1
407WL01SO16.0N	A96029703	SO	353.2	Nitrate-Nitrite	0.4 U	mg/Kg	0.4	0.2	1
407WL01SO16.0N	A96029703	SO	351.3	TKN	269	mg/Kg	0.5	0.3	1
407WL01SO16.0N	A96029703	SO	150.1	pH	7.7	units	NA	NA	1
407WL01SO16.0N	A96029703	SO	365.3	Phosphate	20 U	mg/Kg	20	20	1
407WL01SO16.0N	K96361401	SO	D4129	TOC	0.11	Percent	0.05	0.05	1
407WL01SO41.0N	A96029704	SO	350.3	Ammonium	0.5 U	mg/Kg	0.5	0.4	1
407WL01SO41.0N	A96029704	SO	353.2	Nitrate-Nitrite	0.4 U	mg/Kg	0.4	0.2	1
407WL01SO41.0N	A96029704	SO	351.3	TKN	94.8	mg/Kg	0.5	0.3	1
407WL01SO41.0N	A96029704	SO	150.1	pH	8.6	units	NA	NA	1
407WL01SO41.0N	A96029704	SO	365.3	Phosphate	20 U	mg/Kg	20	20	1
407WL01SO41.0N	K96361402	SO	D4129	TOC	0.09	Percent	0.05	0.05	1
407WL01SO41.0N DUP	A96029706	SO	350.3	Ammonium	0.5 U	mg/Kg	0.5	0.4	1
407WL01SO41.0N DUP	A96029706	SO	353.2	Nitrate-Nitrite	0.4 U	mg/Kg	0.4	0.2	1
407WL01SO41.0N DUP	A96029706	SO	351.3	TKN	116	mg/Kg	0.5	0.3	1
407WL01SO41.0N DUP	A96029706	SO	150.1	pH	8.7	units	NA	NA	1
407WL01SO41.0N DUP	A96029706	SO	365.3	Phosphate	20 U	mg/Kg	20	20	1
407WL01SO41.0N DUP	K96361403	SO	D4129	TOC	0.07	Percent	0.05	0.05	1

NOTES:
MRL = Method reporting limit.
MDL = Method detection limit.
U = Not-detected at MRL.
Dil = Dilution.