



**HILCORP BEAVER CREEK UNIT PAD 4, CANNERY LOOP UNIT
PAD 3, AND KENAI GAS FIELD GROUNDWATER MONITORING
PROGRAM
FINAL 2023 WORK PLAN ADDENDUM**

Date:	6/1/2023
Revision:	0
Project:	Beaver Creek Unit Pad 4, Cannery Loop Unit Pad 3, and Kenai Gas Field
To:	Peter Campbell, ADEC
From:	Drew Anderson, Hilcorp Alaska, LLC
Attachments:	Attachment 1 – Figures Attachment 2 - Tables Attachment 3 – Standard Operating Procedures Attachment 4 – Laboratory Certifications Attachment 5 – Resumes

1. INTRODUCTION

This Work Plan Addendum describes the sampling activities that will be performed by ARS Aleut Remediation, LLC (Aleut) as part of long-term groundwater monitoring at Beaver Creek Unit Pad 4 (BCU4), Cannery Loop Unit Pad 3 (CLU3), and Kenai Gas Field (KGF) in Cook Inlet and Kenai, Alaska (Attachment 1, Figure 1). It is intended to supplement the Final 2021 Groundwater Monitoring Program Work Plan prepared by Brice Engineering, LLC (Brice 2021a), referred to hereinafter as the 2021 Work Plan. Sites included in this project are BCU4 North, BCU4 South, CLU3, KGF Pad 14-6, KGF Pad 34-31, KGF Pad 41-7, and KGF Pad 41-18. Table 1-1 summarizes the site names and associated Alaska Department of Environmental Conservation (ADEC) Hazard identification numbers (IDs).

Table 1-1: Site Name and ADEC Hazard IDs

SITE NAME	ADEC HAZARD ID
BCU4 North	26624
BCU4 South	1005
CLU3	2063

Table 1-1: Site Name and ADEC Hazard IDs

SITE NAME	ADEC HAZARD ID
KGF Pad 14-6	2434
KGF Pad 34-31	3331
KGF Pad 41-7	3191
KGF Pad 41-18	3189

1.1 Site Background

Previous Monitoring activities have been conducted at BCU4 and KGF since 1995, and CLU3 since 1998, as described in the 2021 Groundwater Monitoring Program Reports for BCU4, CLU3, and KGF (Brice 2021b, 2021c, 2022).

1.2 Key Personnel and Qualifications

Key personnel along with their roles and contact information are provided in Table 1-2. Groundwater monitoring activities will be conducted by Aleut personnel who meet the requirements of ADEC Qualified Environmental Professionals in accordance with 18 Alaska Administrative Code (AAC) 75.333 (ADEC 2023). Resumes are provided in Attachment 5.

Table 1-2: Key Personnel and Contact Information

NAME	ORGANIZATION	TITLE	PHONE NUMBER	EMAIL
Drew Anderson	Hilcorp	Project Manager	O: (907) 777-8488 C: (907) 382-0987	ananderson@hilcorp.com
Shauna Holben	Hilcorp	Environmental Representative	O: (907) 283-1358 C: (907) 947-9137	sholben@hilcorp.com
Jacob Nordwall	Hilcorp	Health and Safety Representative	O: (907) 777-8418 C: (907) 748-0753	jacob.nordwall@hilcorp.com
Chad Johnson	Hilcorp	BCU, CLU, KGF Foremen	(907) 283-1325	cjohnson@hilcorp.com
Mike Chivers/ Mike Morgan	Hilcorp	BCU Lead Operators	(907) 283-1316 (907) 283-1317	mchivers@hilcorp.com / mmorgan@hilcorp.com
Zach Rohr/ Andy Graves	Hilcorp	CLU, KGF Lead Operators	(907) 283-1305	zrohr@hilcorp.com/ agraves@hilcorp.com
Kelly Carson	Hilcorp	Project Chemist	(907) 350-6472	kelly.carson@hilcorp.com
Quinn Meehan	Aleut	Program Manager	(808) 394-7940	quinn.meehan@aar.aleutfederal.com
Sara Hadden	Aleut	Project Manager	(907) 350-0712	sara.hadden@aar.aleutfederal.com
Nicole Mattice	Aleut	Field Manager/ Engineer	(970) 301-6960	nicole.mattice@aar.aleutfederal.com

Table 1-2: Key Personnel and Contact Information

NAME	ORGANIZATION	TITLE	PHONE NUMBER	EMAIL
Kyle Therrien	Aleut	Field Support/ Geologist/ Surveyor	(907) 350-0023	kyle.therrien@aar.aleutfederal.com
Karina Packer	Aleut	Field Support/ Engineer	(907) 306-2259	karina.packer@aar.aleutfederal.com
Jacob Bougere	Aleut	Field Support/ Engineer	(907) 230-6983	jacob.bougere@aar.aleutfederal.com
Nathaniel Gingery	Aleut	Field Support/ Chemist	(907) 947-7905	nathaniel.gingery@aar.aleutfederal.com

1.3 Project Schedule

The proposed project schedule is provided in Table 1-3.

Table 1-3: Project Schedule

DESCRIPTION	DURATION (DAYS)	START DATE	END DATE
Planning			
Draft Work Plan	39	3/6/2023	4/14/2023
ADEC review	30	4/14/2023	5/14/2023
Response to ADEC comment	7	5/14/2023	5/21/2023
Final Work Plan		5/21/2023	5/21/2023
Field Work			
Mobilization	1	6/21/2023	6/21/2023
Field Activities	10	6/21/2023	6/30/2023
Demobilization	1	7/1/2023	7/1/2023
Laboratory analysis	30	7/1/2023	8/1/2023
Reporting			
Draft reporting	90	8/1/2023	11/1/2023
ADEC review	30	11/1/2023	12/1/2023
Response to ADEC comments	7	12/1/2023	12/8/2023
Final reporting		12/8/2023	12/8/2023

2. REGULATORY FRAMEWORK

Analytical results from groundwater samples will be compared to the groundwater cleanup levels listed in 18 AAC 75.345, Table C as presented in 18 AAC 75 (ADEC 2023). Analytical results from surface water samples will be used to calculate total aromatic hydrocarbons (TAH) and total aqueous hydrocarbons (TAQH), and these results will be compared to the criteria presented in 18 AAC 70.020 (ADEC 2020). Laboratory reporting limits for the selected laboratories, SGS North

America, Inc. (SGS) in Anchorage, Alaska and Bio-Chem Laboratory in Grand Rapids, MI, are also provided in Table 2-1.

Table 2-1: Groundwater Cleanup Levels and Surface Water Quality Criteria

ANALYTE	ANALYTICAL METHOD	PROJECT SCREENING LEVELS ¹ (µG/L)	LAB DETECTION LIMIT (µG/L)	LAB LIMIT OF DETECTION (µG/L)	LAB LIMIT OF QUANTITATION (µG/L)
GRO	AK101	2,200	45	50	100
DRO	AK102/103 LV	1,500	200	300	600
RRO	AK102/103 LV	1,100	200	250	500
Benzene	SW8260D	4.6	0.12	0.2	0.4
Toluene	SW8260D	1,100	0.31	0.5	1
Ethylbenzene	SW8260D	15	0.31	0.5	1
Xylenes	SW8260D	190	1	1.5	3
1,2,4-Trimethylbenzene	SW8260D	56	0.31	0.5	1
1,3,5-Trimethylbenzene	SW8260D	60	0.31	0.5	1
Isopropylbenzene (Cumene)	SW8260D	450	0.31	0.5	1
n-Butylbenzene	SW8260D	1,000	0.31	0.5	1
sec-Butylbenzene	SW8260D	2,000	0.31	0.5	1
tert-Butylbenzene	SW8260D	690	0.31	0.5	1
1-Methylnaphthalene	SW8270D SIM	11	0.015	0.025	0.05
2-Methylnaphthalene	SW8270D SIM	36	0.015	0.025	0.05
Acenaphthene	SW8270D SIM	530	0.015	0.025	0.05
Acenaphthylene	SW8270D SIM	260	0.015	0.025	0.05
Anthracene	SW8270D SIM	1,800	0.015	0.025	0.05
Benzo[a]anthracene	SW8270D SIM	0.3	0.015	0.025	0.05
Benzo[a]pyrene	SW8270D SIM	0.25	0.0062	0.01	0.02
Benzo[b]fluoranthene	SW8270D SIM	2.5	0.015	0.025	0.05
Benzo[g,h,i]perylene	SW8270D SIM	600	0.015	0.025	0.05
Benzo[k]fluoranthene	SW8270D SIM	25	0.015	0.025	0.05
Chrysene	SW8270D SIM	250	0.015	0.025	0.05
Dibenzo[a,h]anthracene	SW8270D SIM	0.25	0.0062	0.01	0.02
Fluoranthene	SW8270D SIM	800	0.015	0.025	0.05
Fluorene	SW8270D SIM	290	0.015	0.025	0.05
Indeno[1,2,3-cd]pyrene	SW8270D SIM	2.5	0.015	0.025	0.05
Naphthalene	SW8270D SIM	1.7	0.031	0.05	0.1
Phenanthrene	SW8270D SIM	170	0.031	0.05	0.1
Pyrene	SW8270D SIM	120	0.015	0.025	0.05
Ethylene glycol ²	SW8015C	40,000	10,000	10,000	10,000
1,4-Dioxane	SW8260D SIM	4.6	0.1	0.2	0.4
TAH ³	--	10	--	--	--
TAqH ³	--	15	--	--	--

Notes:

¹ Groundwater cleanup levels as listed in 18 AAC 75.345, Table C (ADEC 2023), unless otherwise noted.

² Limits presented are for Bio-Chem Laboratory. Ethylene glycol is the only analyte that will be sent to this laboratory.

³ Surface water quality criteria from 18 AAC 70.020 (ADEC 2020).

DRO = diesel range organics

GRO = gasoline range organics

RRO = residual range organics

TAH = total aromatic hydrocarbons, the sum of benzene, toluene, ethylbenzene, and xylenes (BTEX) concentrations

TAqH = total aqueous hydrocarbons, the sum of BTEX and PAH (excluding 1-methylnaphthalene and 2-methylnaphthalene) concentrations

3. FIELD ACTIVITIES

Visual site assessments; groundwater monitoring well inspections; maintenance (as needed); gauging, purging, and sampling; free product recovery; and surface water sampling will be conducted in accordance with the ADEC *Field Sampling Guidance* (ADEC 2022a), procedures in the 2021 Work Plan (Brice 2021a), and the updated 2023 field activities described below. Table 3-1 summarizes the anticipated field activities for 2023, including the total number of wells at each site to be inspected and sampled/gauged, the number of wells anticipated to contain light non-aqueous phase liquid (LNAPL), and planned surface water samples. Table 3-2 identifies updates to the 2021 Work Plan (Brice 2021a). All monitoring wells sampled on a biennial basis and most wells scheduled for sampling once every four years fall on the same 2023 sampling schedule. The wells that will be sampled in 2023 with a once every four years sampling frequency are noted in the attached Well Status Table (Table 1, Attachment 2). Additionally, site-specific sampling information and 2023 recommendations for each well are provided in the attached Well Status Table (Table 1, Attachment 2). The 2021 Work Plan (Brice 2021a) and this 2023 Work Plan Addendum will be provided in the field for field personnel to reference.

Table 3-1: 2023 Site Summary

SITE NAME	WELLS TO BE INSPECTED ¹	WELLS TO BE SAMPLED ² AND GAUGED	WELLS TO BE GAUGED ONLY	ANTICIPATED LNAPL WELLS	SURFACE WATER SAMPLES
BCU4 North	5	5	0	0	0
BCU4 South	16	10	4	2	0
CLU3	14	9	5	0	0
KGF Pad 14-6	26	19	6	1	8
KGF Pad 34-31	16	13	3	0	0
KGF Pad 41-7	16	15	1	0	7
KGF Pad 41-18	14	12	2	0	5

Notes:

¹ Maintenance to be conducted as needed.

² Primary samples only, QC not included in totals.

Table 3-2: 2023 Updates to the Work Plan

FIELD ACTIVITY ¹	UPDATE(S)	UPDATED REFERENCE ²
2021 Work Plan (Brice 2021)¹	2023 Work Plan Addendum	
Section 3.1 Monitoring Well Inspection and Maintenance	If product is indicated in an anticipated LNAPL well (indicated in Attachment 2), product recovery activities will be conducted as needed and no samples will be collected. Product recovery efforts will be conducted using a poly bailer. Poly bailers will be deployed to remove product with as much product and as little water removed as possible. Sorbent socks in LNAPL wells will be removed, assessed, and recorded. Sorbent socks containing less than 50% saturation will be flipped and placed back down the well after gauging activities are complete. Removed sorbent socks will be disposed of in an oily-waste bag segregated by site and labeled with the site name and well. A new sorbent sock will be placed in the well if necessary.	None
Section 3.2 Monitoring Well Gauging Procedures	Groundwater levels will be gauged in all viable monitoring wells at each site (i.e., BCU4 North, BCU4 South, CLU3, KGF 14-6, KGF 41-7, and KGF 14-18) within a 12-hour time period.	SOP-10 Groundwater Gauging, Monitoring, and Sampling
Section 3.3 Monitoring Well Decommissioning, Installation, and Development	If redevelopment of a well is necessary, SOP-9 will be referenced. No other well decommissioning or installation activities are included in the 2023 scope. Well MW-A at KGF 14-6 was recommended for decommission but this will be performed after other wells are identified for decommissioning.	SOP-9 Monitoring Well Installation, Development, and Decommissioning
Section 3.4 Analytical Sampling	None	SOP-10 Groundwater Gauging, Monitoring, and Sampling
Section 3.4.1 Groundwater Sampling Procedures	If no product is indicated in an anticipated LNAPL well (Table 1, Attachment 2) and this is the first or second time the well is being sampled, the well will be sampled for petroleum-related VOCs (including BTEX) and PAHs.	SOP-10 Groundwater Gauging, Monitoring, and Sampling
Section 3.4.2 Surface Water Sampling Procedures	None	SOP-11 Surface Water Sampling
Section 3.4.3 Analytical Methods and Quality Assurance/Quality Control	At a minimum, one field duplicate (FD) sample will be collected for every 10 or fewer primary samples, for each matrix sampled, and for each target analyte. FDs will be collected at the same location as the primary sample and will be submitted to the laboratory blind with unique sample	SOP-14 Quality Control Samples

Table 3-2: 2023 Updates to the Work Plan

FIELD ACTIVITY ¹	UPDATE(S)	UPDATED REFERENCE ²
2021 Work Plan (Brice 2021) ¹	2023 Work Plan Addendum	
	<p>IDs. When possible, a FD will be included with every sample delivery group (SDG). FDs will be designated by adding a “Z” after the sample location (e.g., KGF417-MW27RZ-23). A sample collection time of 1 hour before sample collection will be created for the duplicate and recorded on the sample labels and CoC forms to ensure it is a blind duplicate.</p> <p>Matrix spike (MS)/matrix spike duplicate (MSD) samples will be collected at a frequency of 5 percent (%) (one MS/MSD set for every 20 or fewer primary samples). When possible, an MS/MSD set will be included with every SDG.</p> <p>One trip blank will accompany each cooler that contains volatile samples. Trip blanks will be identified consecutively (e.g., BCU4N-TB01, KGF146-TB01, etc.).</p>	
Section 3.4.4 Sample Identification	<p>Collected samples will be assigned a unique field-sample ID reflecting the sample year and location. Groundwater samples will be numbered with unique identifiers as follows:</p> <ul style="list-style-type: none"> • The first set of digits designates the site identification (e.g., “CLU3” for CLU3, “BCU4N” for BCU4 North, “BCU4S” for BCU4 South, “KGF146” KGF Pad 14-6, “KGF417” KGF Pad 41-7, and “KGF4118” KGF Pad 41-18) • The second set of digits indicates the sample location (e.g., “AP4” for monitoring well AP-4, “MW21R2” for monitoring well MW-21R2, or “SW01” for surface water sample location 1, etc.) • The third set of digits indicates the last two digits of the fiscal year (e.g., “23” for 2023) <p>Examples of sample IDs are as follows:</p> <ul style="list-style-type: none"> • BCU4S-AP10R-23 • CLU3-PZ1-23 • KGF3431-MW11-23 	None
Section 3.5 Sample Handling and Chain-of-Custody	Samples will be transported to Anchorage on the Hilcorp Twin Otter.	SOP-17 Sample Management

Table 3-2: 2023 Updates to the Work Plan

FIELD ACTIVITY ¹	UPDATE(S)	UPDATED REFERENCE ²
2021 Work Plan (Brice 2021) ¹	2023 Work Plan Addendum	
Section 3.6 Decontamination	None	SOP-15 Equipment Decontamination
Section 3.7 Waste Management	Estimated waste stream quantities were updated in the attached Anticipated Waste Streams Table (Table 2, Attachment 2).	None
Section 3.8 Field Documentation	Field personnel will document sample handling activities, observations, and data using digital field sampling records, including field forms (e.g., field instrument calibration logs, visual site assessments, well inspection/maintenance/groundwater gauging, groundwater sampling, surface water sampling, CoCs, waste-tracking log, etc.) and photographs.	SOP-18 Logbook Documentation and Field Notes
Section 3.9 Reporting and Documentation	None	None
	<p>Addition to the 2023 Work Plan Addendum</p> <p>Survey</p> <p>Monitoring wells can be affected by freeze-thaw processes creating frost heaving that vertically affects the original well installment. If any well is heaved or jacked to the extent the well cover cannot be closed and locked, the change in well condition will be documented during groundwater monitoring activities and the well casing cut down prior to the survey effort. The vertical position of all wells will be resurveyed to ensure accurate top-of-casing elevations. The elevation, ground surface elevation, and top-of-casing elevation at all viable BCU, CLU, and KGF monitoring wells will be surveyed utilizing the previously established survey control monuments and their respective values, based on historical data made available by Hilcorp. Elevations will be determined using third order differential leveling, using an automatic level.</p> <p>Northing and easting will also be surveyed at monitoring wells not previously surveyed and historical position locations will be reused for any monitoring well previously surveyed. Horizontal positions will be determined using real-time-kinematic Global Navigation Satellite System surveying techniques. The survey will be performed with a horizontal accuracy of 1.0 foot and vertical accuracy of 0.01 feet. Geospatial data resulting from the surveys will be provided in North</p>	

Table 3-2: 2023 Updates to the Work Plan

FIELD ACTIVITY ¹	UPDATE(S)	UPDATED REFERENCE ²
2021 Work Plan (Brice 2021) ¹	2023 Work Plan Addendum	
	American Datum (NAD) of 1983 (2011) (more specifically, IGS08 [Epoch 20010.0000]) Northing and Easting, in U.S. survey feet. Elevations will be provided in the North American Vertical Datum of 1988, in feet. Features created from the survey data will be projected in the NAD 1983 (2011) Alaska State Plane, Zone 4.	

Notes:

¹ Section titles from the 2021 Work Plan (Brice 2021a).

² Referenced SOPs are included in Attachment 3.

4. DATA QUALITY MANAGEMENT

The purpose of the data quality management program is to establish the analytical and documentation protocols to be used when reviewing and analyzing data collected for this project. The overall QC objectives for the laboratory activities are to develop and implement procedures for obtaining and evaluating data in an accurate, precise, and complete manner so that measurement data and laboratory procedures provide information that is comparable to and representative of actual field conditions. Data quality will be evaluated by the Hilcorp Chemist based on the data quality indicators, including precision, accuracy, representativeness, completeness, and comparability (PARCCS). Data validation will be performed using the QC criteria in the 2021 Work Plan (Brice 2021), the Guidelines for Data Reporting (ADEC 2022b), specific analytical method guidance, and laboratory control limits for precision and accuracy.

5. REFERENCES

- Alaska Department of Environmental Conservation (ADEC). 2020. *18 AAC 70, Water Quality Standards*, as amended through 5 March.
- ADEC. 2022a. *Field Sampling Guidance*. Division of Spill Prevention and Response. Contaminated Sites Program. January.
- ADEC. 2022b. *Guidelines for Data Reporting*. Technical Memorandum 22-001. August.
- ADEC. 2023. *18 Alaska Administrative Code (AAC) 75, Oil and Other Hazardous Substances Pollution Control*, as amended through 5 February.
- Brice Engineering, LLC (Brice). 2021a. *2021 Groundwater Monitoring Program Work Plan, Kenai Peninsula Sites, Alaska, Beaver Creek Unit, Cannery Loop Unit, and Kenai Gas Field Contaminated Sites*. June.
- Brice. 2021b. *2021 Groundwater Monitoring Program Report, Kenai Peninsula Sites, Alaska, Cannery Loop Unit Pad 3*. November.
- Brice. 2021c. *2021 Groundwater Monitoring Program Report, Kenai Peninsula Sites, Alaska, Beaver Creek Unit Pad 4*. December.
- Brice. 2022. *2021 Groundwater Monitoring Program Report, Kenai Peninsula Sites, Alaska, Kenai Gas Field*. January.

This page intentionally blank

ATTACHMENT 1

FIGURES

This page intentionally blank

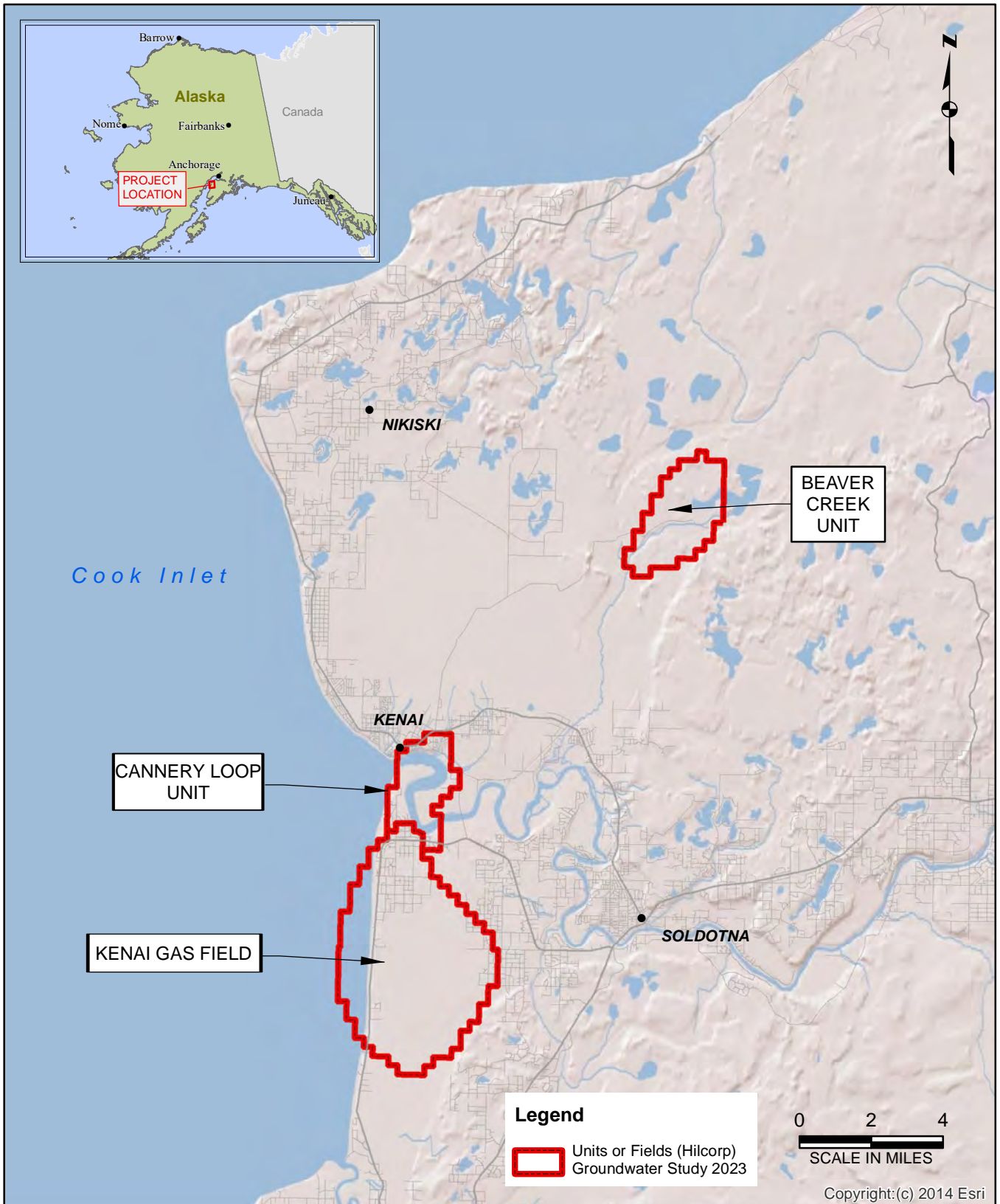

2023 GROUNDWATER MONITORING PROGRAM WORK PLAN
 BEAVER CREEK UNIT PAD 4, CANNERY LOOP UNIT PAD 3,
 AND KENAI GAS FIELD
 Kenai Peninsula, Alaska

STATE AND SITE VICINITY

DATE:
4/14/2023

PROJECT NO:

DRAWN:

FIGURE
1

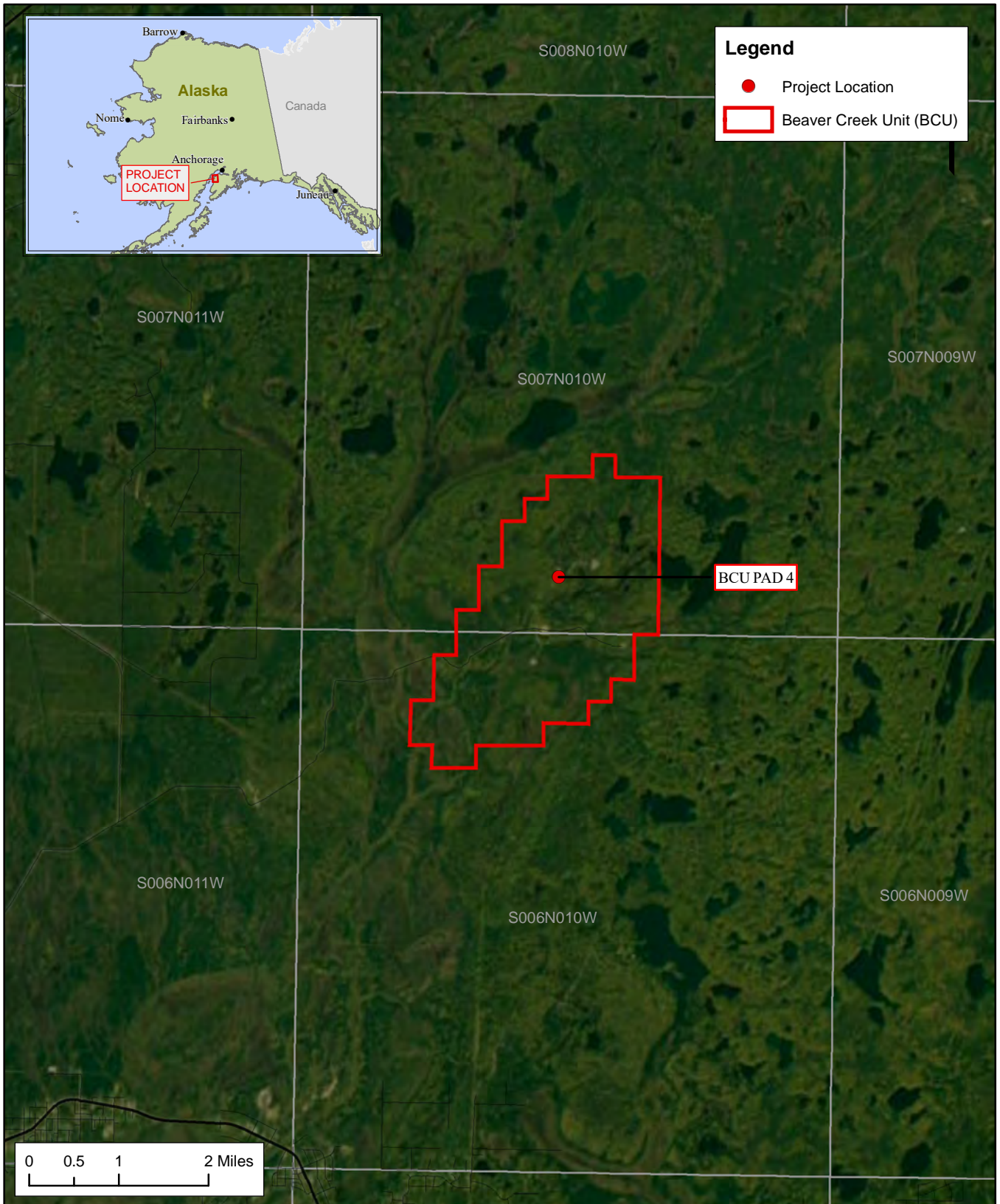

2023 GROUNDWATER MONITORING PROGRAM WORK PLAN
 BEAVER CREEK UNIT
 Kenai Peninsula, Alaska

SITE MAP

DATE:
4/13/2023

PROJECT NO:

DRAWN:

FIGURE
2



Legend

- Project Location
- Cannery Loop Unit (CLU)



 Hilcorp Alaska, LLC <small>3800 Centerpoint Dr. Ste. 1400 Anchorage, AK 99503</small>	<p>2023 GROUNDWATER MONITORING PROGRAM WORK PLAN</p> <p>CANNERY LOOP UNIT</p> <p>Kenai Peninsula, Alaska</p> <hr/> <p>SITE MAP</p>	<p>DATE: 4/13/2023</p> <hr/> <p>PROJECT NO:</p> <hr/> <p>DRAWN:</p> <hr/>	<p>FIGURE</p> <p>3</p>
--	---	---	-------------------------------

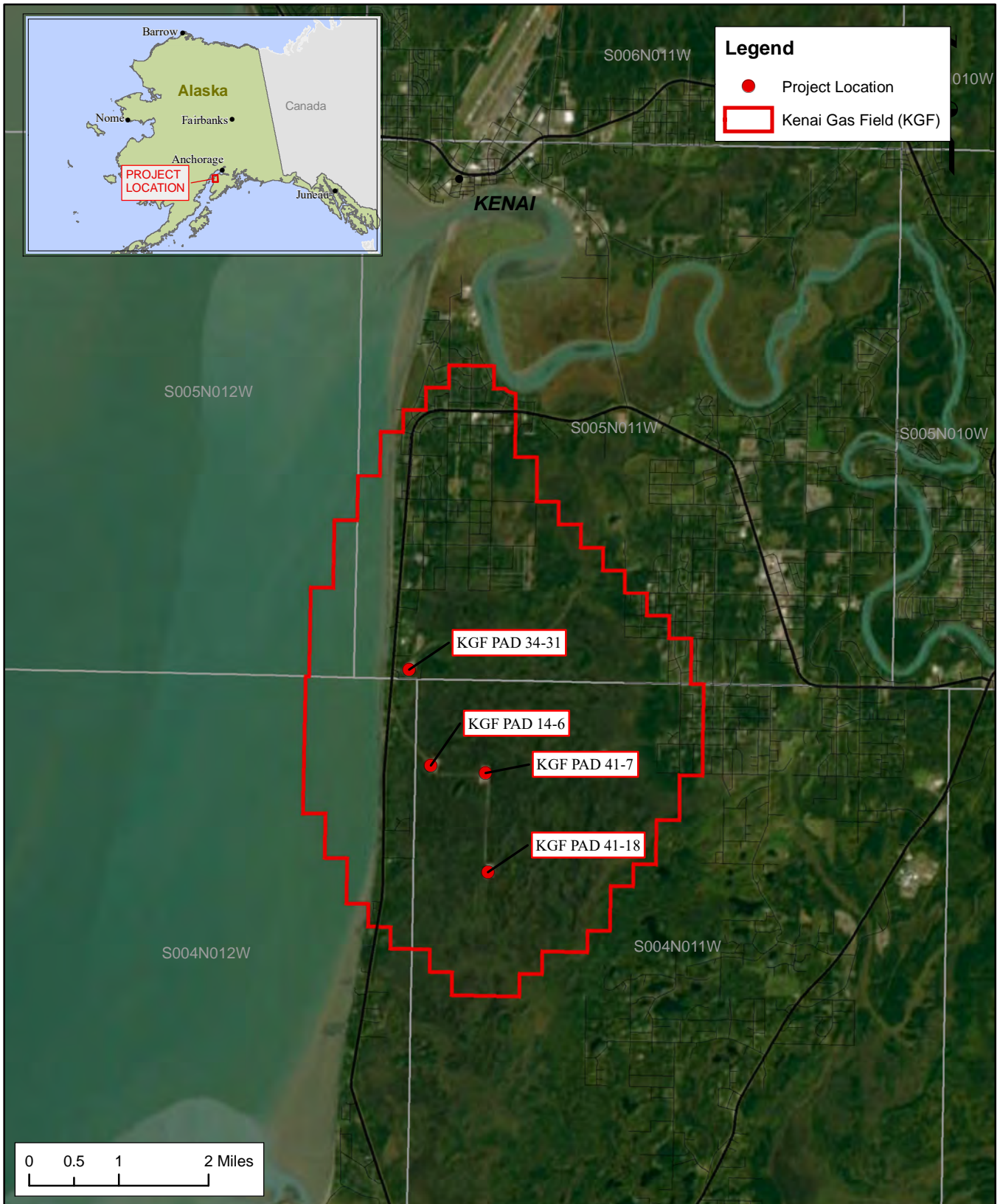

2023 GROUNDWATER MONITORING PROGRAM WORK PLAN
 KENAI GAS FIELD
 Kenai Peninsula, Alaska

SITE MAP

DATE:
4/12/2023

PROJECT NO:

DRAWN:

FIGURE
4

HILCORP BEAVER CREEK UNIT,
CANNERY LOOP UNIT AND KENAI GAS FIELD
GROUNDWATER MONITORING PROGRAM
2023 WORK PLAN ADDENDUM

KENAI PENINSULA, ALASKA

**BEAVER CREEK UNIT PAD 4
Monitoring Well Locations
and Groundwater Flow Direction**

Legend

- 7.9 Groundwater Elevation (Feet)
- ➔ Approximate Groundwater Flow Direction
- Groundwater Contour (Feet)
- Monitoring Well Location
 - ⊕ Gauge Only
 - ⊗ Gauge and Sample
 - ⊗ (with red dot) Gauge and Sample; Previous Exceedance
 - ⊕ (with red dot) Gauge - LNAPL Previously Present; Sample if no LNAPL

NOTES:

1. For conceptual purposes only. All viable monitoring wells were surveyed in 2021. All other site feature locations are approximate.
2. Imagery acquired from NV5. Imagery was taken on 31 May 2021.
3. All presented groundwater results are based on findings from 2021 activities and compared to Alaska Department of Environmental Conservation (ADEC) Table C groundwater cleanup levels (ADEC 2021).
4. Groundwater elevations are expressed in feet (North American Vertical Datum of 1988). Map in North American Datum of 1983 (2011) Alaska State Plane Zone 4.
5. Groundwater contours were generated with Surfer 16 software using kriging.
6. Water levels at AP-15 and AP-29 were adjusted for the approximate specific gravity (0.80) of the 0.63 feet and 1.65 feet of LNAPL measured in these wells in 2021, respectively.



0 15 30 60 Feet

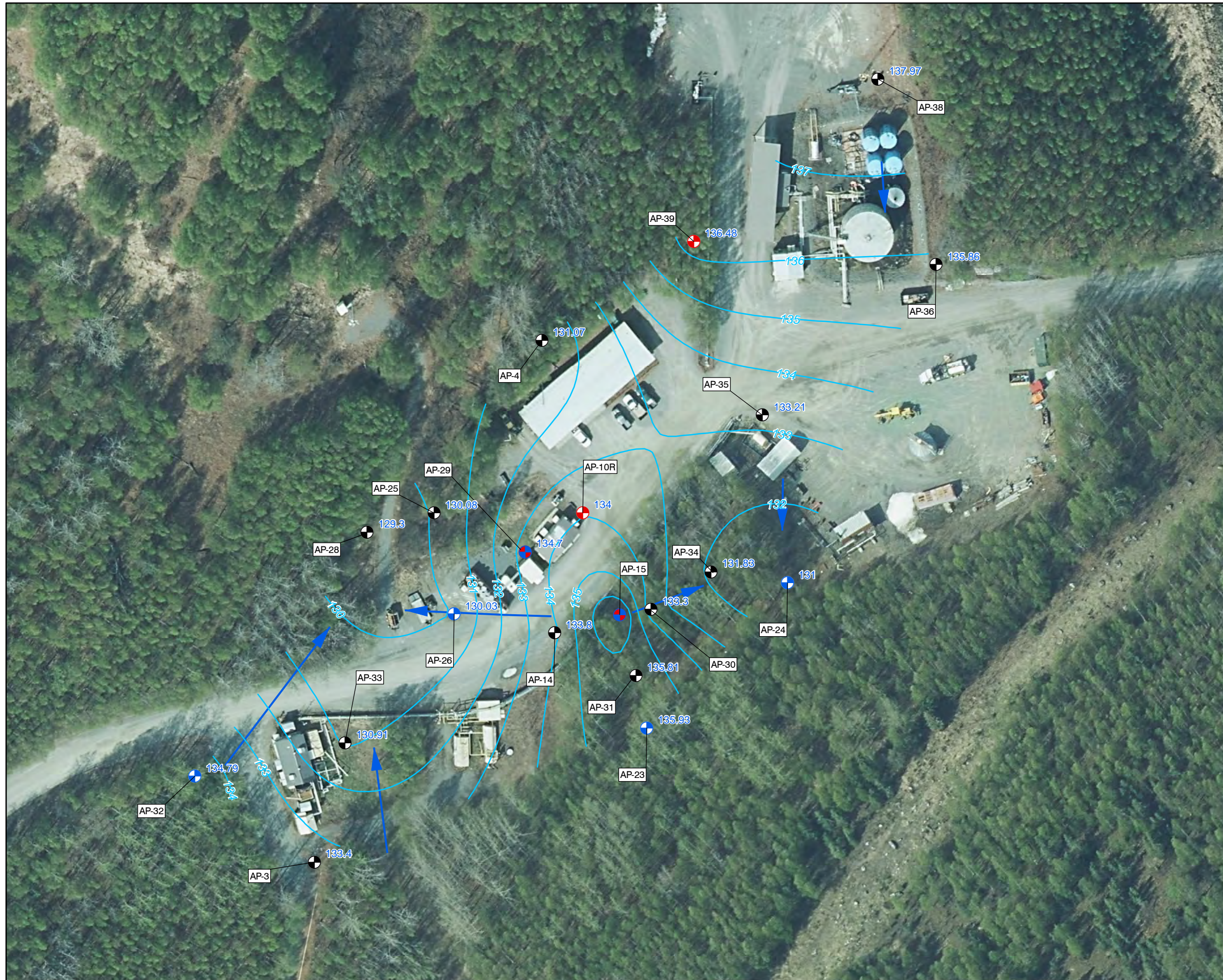

DATE:
4/18/2023

PROJECT NO:

DRAWN:

FIGURE
5

HILCORP BEAVER CREEK UNIT,
CANNERY LOOP UNIT AND KENAI GAS FIELD
GROUNDWATER MONITORING PROGRAM
2023 WORK PLAN ADDENDUM

KENAI PENINSULA, ALASKA

**CANNERY LOOP UNIT PAD 3
Monitoring Well Locations
and Groundwater Flow Direction**

Legend

- 7.9 Groundwater Elevation (Feet)
- ➔ Approximate Groundwater Flow Direction
- Groundwater Contour (Feet)
- Monitoring Well Location
 - ⊕ Gauge Only
 - ⊙ Gauge and Sample
 - ⊙ Gauge and Sample; Previous Exceedance
 - ⊙ Gauge - LNAPL Previously Present; Sample if no LNAPL

NOTES:

1. For conceptual purposes only. All viable monitoring wells were surveyed in 2021. All other site feature locations are approximate.
2. Imagery acquired from NV5. Imagery was taken on 31 May 2021.
3. All presented groundwater results are based on findings from 2021 activities and compared to Alaska Department of Environmental Conservation (ADEC) Table C groundwater cleanup levels (ADEC 2021).
4. Groundwater elevations are expressed in feet (North American Vertical Datum of 1988). Map in North American Datum of 1983 (2011) Alaska State Plane Zone 4.
5. Groundwater contours were generated with Surfer 16 software using kriging.
6. Monitoring wells PZ-1 and PZ-2 were not included in the groundwater model because they were observed to be dry during 2021 gauging activities.



0 12.5 25 50 Feet



DATE:
4/18/2023
PROJECT NO:
DRAWN:

FIGURE
6

HILCORP BEAVER CREEK UNIT,
CANNERY LOOP UNIT AND KENAI GAS FIELD
GROUNDWATER MONITORING PROGRAM
2023 WORK PLAN ADDENDUM

KENAI PENINSULA, ALASKA

**KENAI GAS FIELD PAD 14-6
Monitoring Well Locations
and Groundwater Flow Direction**

Legend

- 7.9 Groundwater Elevation (Feet)
- ➔ Approximate Groundwater Flow Direction
- Groundwater Contour (Feet)
- Monitoring Well Location
 - ⊕ Gauge Only
 - ⊗ Gauge and Sample
 - ⊗ Gauge and Sample; Previous Exceedance
 - ⊕ Gauge - LNAPL Previously Present; Sample if no LNAPL
 - ▲ Surface Water Sample Location

NOTES:

1. For conceptual purposes only. All viable monitoring wells were surveyed in 2021. All other site feature locations are approximate.
2. Imagery acquired from NV5. Imagery was taken on 31 May 2021.
3. All presented groundwater results are based on findings from 2021 activities and compared to Alaska Department of Environmental Conservation (ADEC) Table C groundwater cleanup levels (ADEC 2021).
4. Groundwater elevations are expressed in feet (North American Vertical Datum of 1988). Map in North American Datum of 1983 (2011) Alaska State Plane Zone 4.
5. Groundwater contours were generated with Surfer 16 software using kriging.
6. Groundwater elevations for monitoring wells MW-8, MW-9, MW-26, and MW-33 are considered estimated because the wells were gauged outside the 2-hour timeframe.
7. Water levels at monitoring wells MW-23 and MW-41 were adjusted for the approximate specific gravity (0.80) of the 0.17 feet and 3.01 feet of light non-aqueous phase liquid measured in these wells in 2021, respectively.



0 20 40 80 Feet

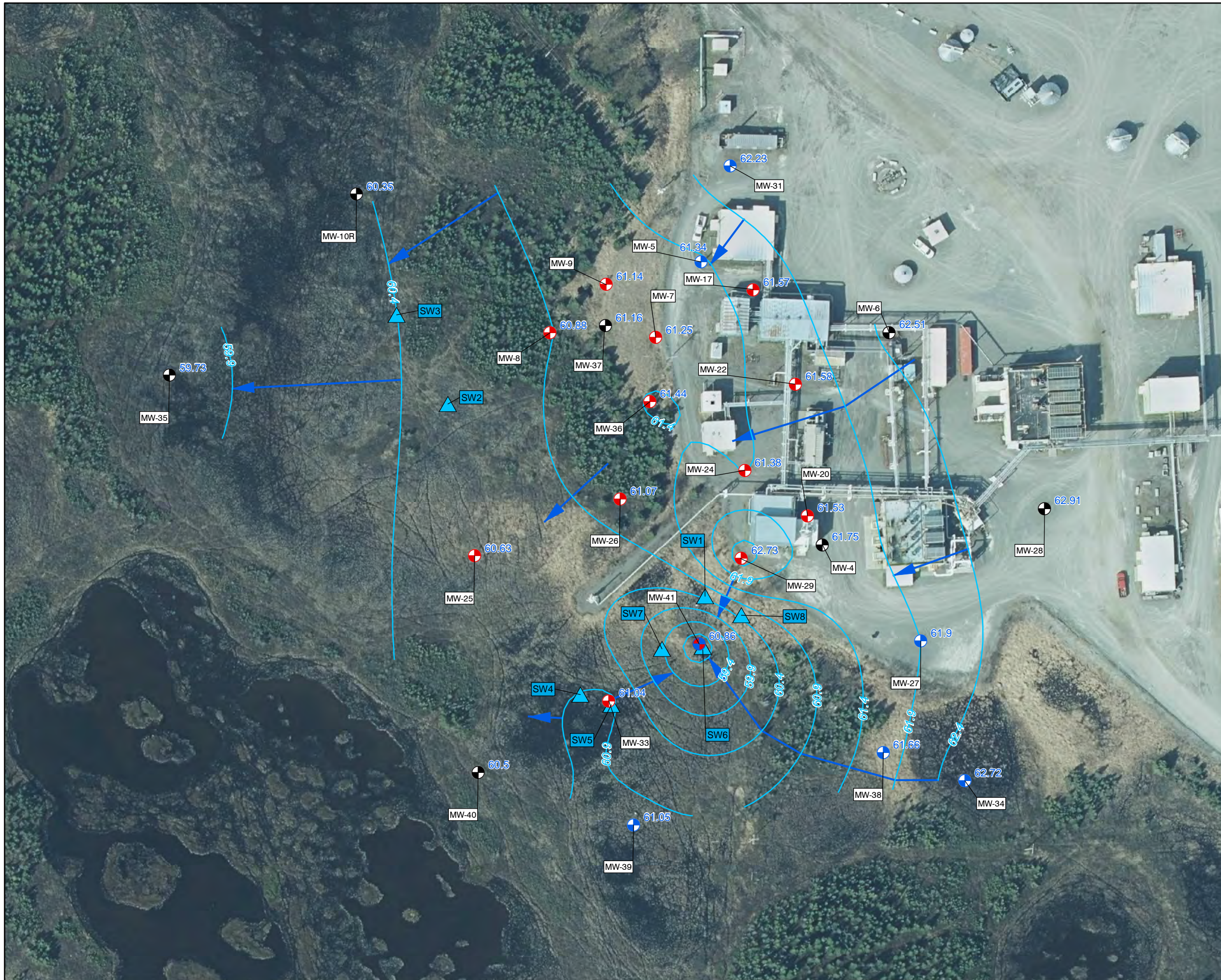

DATE:
4/18/2023
PROJECT NO:
DRAWN:

FIGURE
7

HILCORP BEAVER CREEK UNIT,
CANNERY LOOP UNIT AND KENAI GAS FIELD
GROUNDWATER MONITORING PROGRAM
2023 WORK PLAN ADDENDUM

KENAI PENINSULA, ALASKA

**KENAI GAS FIELD PAD 34-31
Monitoring Well Locations
and Groundwater Flow Direction**

Legend

- 7.9 Groundwater Elevation (Feet)
- ➔ Approximate Groundwater Flow Direction
- Groundwater Contour (Feet)
- Monitoring Well Location**
- ⊕ Gauge Only
- ⊙ Gauge and Sample
- ⊕⊙ Gauge and Sample; Previous Exceedance
- ⊕⊙⊙ Gauge - LNAPL Previously Present; Sample if no LNAPL



NOTES:

1. For conceptual purposes only. All viable monitoring wells were surveyed in 2021. All other site feature locations are approximate.
2. Imagery acquired from NV5. Imagery was taken on 31 May 2021.
3. All presented groundwater results are based on findings from 2021 activities and compared to Alaska Department of Environmental Conservation (ADEC) Table C groundwater cleanup levels (ADEC 2021).
4. Groundwater elevations are expressed in feet (North American Vertical Datum of 1988). Map in North American Datum of 1983 (2011) Alaska State Plane Zone 4.
5. Groundwater contours were generated with Surfer 16 software using kriging.



0 20 40 80 Feet



DATE:
4/18/2023

PROJECT NO:

DRAWN:

FIGURE

8

HILCORP BEAVER CREEK UNIT,
CANNERY LOOP UNIT AND KENAI GAS FIELD
GROUNDWATER MONITORING PROGRAM
2023 WORK PLAN ADDENDUM
KENAI PENINSULA, ALASKA

**KENAI GAS FIELD PAD 41-7
Monitoring Well Locations
and Groundwater Flow Direction**

Legend

- 7.9 Groundwater Elevation (Feet)
- ➔ Approximate Groundwater Flow Direction
- Groundwater Contour (Feet)
- Monitoring Well Location
 - ⊕ Gauge Only
 - ⊙ Gauge and Sample
 - ⊙ (with red center) Gauge and Sample; Previous Exceedance
 - ⊙ (with blue center) Gauge - LNAPL Previously Present; Sample if no LNAPL
 - ▲ Surface Water Sample Location

NOTES:

1. For conceptual purposes only. All viable monitoring wells were surveyed in 2021. All other site feature locations are approximate.
2. Imagery acquired from NV5. Imagery was taken on 31 May 2021.
3. All presented groundwater results are based on findings from 2021 activities and compared to Alaska Department of Environmental Conservation (ADEC) Table C groundwater cleanup levels (ADEC 2021).
4. Groundwater elevations are expressed in feet (North American Vertical Datum of 1988). Map in North American Datum of 1983 (2011) Alaska State Plane Zone 4.
5. Groundwater contours were generated with Surfer 16 software using kriging.
6. Monitoring wells MW-21R, MW-27, and MW-36 are included in the groundwater model although they no longer exist. Groundwater elevations for these monitoring wells are considered estimated due to decommissioning after 2021 survey activities and existing survey data from 2017 was used.
7. Monitoring wells MW-23R, MW-25, and MW-33 are not included in the groundwater model because they were inaccessible at the time of gauging. Monitoring well MW-36 is also not included because no previous survey data exists and was decommissioned prior to 2021 survey activities.
8. Monitoring wells MW-21R2, MW-23R2, MW-25R, MW-27R, MW-36R, MW-38, and MW-39 were installed after the completion of 2021 gauging activities.
9. An observed peat layer beneath the gravel pad may be influencing groundwater elevations in monitoring wells screened across the peat layer.



0 20 40 80 Feet



DATE:
4/18/2023
PROJECT NO:
DRAWN:

FIGURE
9

HILCORP BEAVER CREEK UNIT,
CANNERY LOOP UNIT AND KENAI GAS FIELD
GROUNDWATER MONITORING PROGRAM
2023 WORK PLAN ADDENDUM
KENAI PENINSULA, ALASKA

**KENAI GAS FIELD PAD 41-18
Monitoring Well Locations
and Groundwater Flow Direction**

- Legend**
- 7.9 Groundwater Elevation (Feet)
 - ▶ Approximate Groundwater Flow Direction
 - Groundwater Contour (Feet)
 - Monitoring Well Location**
 - Gauge Only
 - Gauge and Sample
 - Gauge and Sample; Previous Exceedance
 - Gauge - LNAPL Previously Present; Sample if no LNAPL
 - ▲ Surface Water Sample Location



- NOTES:**
1. For conceptual purposes only. All viable monitoring wells were surveyed in 2021. All other site feature locations are approximate.
 2. Imagery acquired from NV5. Imagery was taken on 31 May 2021.
 3. All presented groundwater results are based on findings from 2021 activities and compared to Alaska Department of Environmental Conservation (ADEC) Table C groundwater cleanup levels (ADEC 2021).
 4. Groundwater elevations are expressed in feet (North American Vertical Datum of 1988). Map in North American Datum of 1983 (2011) Alaska State Plane Zone 4.
 5. Groundwater contours were generated with Surfer 16 software using kriging.
 6. Monitoring wells MW-3R, MW-17, and MW-18 are included in the groundwater model although they no longer exist. Groundwater elevations for these monitoring wells are considered estimated because they were decommissioned after survey activities were conducted in 2021 and existing survey data from 2017 was used.
 7. Monitoring wells MW-3R2, MW-17R, and MW-18R were installed after the completion of 2021 Gauging activities.



0 20 40 80 Feet



DATE:
4/18/2023

PROJECT NO:

DRAWN:

ATTACHMENT 2

TABLES

This page intentionally blank

Hilcorp Beaver Creek Unit Pad 4, Cannery Loop Unit Pad 3, and Kenai Gas Field Groundwater Monitoring Program
2023 Work Plan Addendum
Kenai Peninsula, Alaska
Table 1: 2023 Well Status

Well ID	Date Well Gauged	Date Well Sampled	Sample ID	QC		2021 Notes	2023 Analysis	Contamination Level (LNAPL, High, Moderate, Low, None)
				Dup	MS/MSD			
Beaver Creek Unit Pad 4 North								
AP-4	7/9/2021	7/9/2021	BCU4NS-AP4-23		X	Soft hit at bottom.	GRO, DRO, RRO, benzene, ethylbenzene, toluene, 1,2,4-trimethylbenzene, naphthalene, and xylenes	Low
AP-35	7/9/2021	7/10/2021	BCU4N-AP35-23			Flush mount. Hard hit at bottom.	GRO, DRO, RRO, benzene, ethylbenzene, toluene, 1,2,4-trimethylbenzene, naphthalene, and xylenes	Low
AP-36	7/9/2021	7/9/2021	BCU4N-AP36-23			Redeveloped due to observed biological infiltration. Hard hit at bottom. Lock replaced.	GRO, DRO, RRO, benzene, ethylbenzene, toluene, 1,2,4-trimethylbenzene, naphthalene, and xylenes	Low
AP-38	7/9/2021	7/9/2021	BCU4N-AP38-23			Hard hit at bottom. Lock replaced.	GRO, DRO, RRO, benzene, ethylbenzene, toluene, 1,2,4-trimethylbenzene, naphthalene, and xylenes	Low
AP-39	7/9/2021	7/10/2021	BCU4N-AP39-23	X		Some bentonite on probe.	GRO, DRO, RRO, benzene, ethylbenzene, toluene, 1,2,4-trimethylbenzene, naphthalene, and xylenes	Moderate
Beaver Creek Unit Pad 4 South								
AP-3	7/9/2021	7/15/2019	BCU4S-AP3-23	X	X	Hard hit at bottom. Slight HC odor. Scheduled for sampling in 2023 due to sampling frequency of once every 4 years.	DRO, ethylene glycol Dup and MS/MSD analyzed for ethylene glycol only.	Low
AP-4	7/9/2021	7/15/2019	BCU4NS-AP4-23			Soft hit at bottom. Scheduled for sampling in 2023 due to sampling frequency of once every 4 years.	DRO	Low
AP-10	Decommissioned in 2016.							
AP-10R	7/9/2021	7/10/2021	BCU4S-AP10R-23			Flush mount. Hard hit at bottom. No surface infiltration.	DRO, ethylbenzene, and naphthalene	Moderate
AP-14	7/9/2021	7/16/2019	BCU4S-AP14-23			No monument. Safety cone over PVC for protection. Scheduled for sampling in 2023 due to sampling frequency of once every 4 years.	DRO	None
AP-15	7/9/2021	Never sampled - LNAPL present	Gauge and product recovery			Ambient PID reading before sock removal was 16 ppm. Ambient PID reading after sock removal 140.5 ppm. Downhole PID reading after sock removal was 402.1 ppm. Sorbent sock was replaced. Not sampled in 2021 due to LNAPL presence.	Gauge and product recovery	LNAPL
AP-23	7/9/2021	10/4/2010	Gauge only			Semi-soft hit at bottom. Silt on probe.	Gauge Only	None
AP-24	7/9/2021	10/5/2010	Gauge only			Semi-soft hit at bottom.	Gauge Only	Low
AP-25	7/9/2021	7/10/2021	BCU4S-AP25-23			Soft hit at bottom.	DRO, ethylbenzene, and naphthalene	Low
AP-26	7/9/2021	9/16/2013	Gauge only			Hard, sticky hit at bottom. Well plug replaced.	Gauge Only	None
AP-27	Decommissioned in 2021.							
AP-28	7/9/2021	7/16/2019	BCU4S-AP28-23			Soft hit at bottom. Scheduled for sampling in 2023 due to sampling frequency of once every 4 years.	DRO	Low
AP-29	7/9/2021	Never sampled - LNAPL present	Gauge and product recovery			Monitoring well installed on a 28° angle. Ambient PID reading was 51.4 ppm. Downhole PID reading was 415.8 ppm. Lubricant/solvent odor. Black flaking substance in bailed product. Sorbent sock replaced. Not sampled in 2021 due to LNAPL presence.	Gauge and product recovery	LNAPL
AP-30	7/9/2021	7/16/2019	BCU4S-AP30-23			Soft hit at bottom. Scheduled for sampling in 2023 due to sampling frequency of once every 4 years.	DRO	None
AP-31	7/9/2021	7/15/2019	BCU4S-AP31-23			Soft hit at bottom. Scheduled for sampling in 2023 due to sampling frequency of once every 4 years.	DRO	None
AP-32	7/9/2021	9/17/2013	Gauge only			Soft hit at bottom.	Gauge Only	None
AP-33	7/9/2021	7/16/2019	BCU4S-AP33-23			Hard hit at bottom. Scheduled for sampling in 2023 due to sampling frequency of once every 4 years.	DRO	Low
AP-34	7/9/2021	7/16/2019	BCU4S-AP34-23			Soft hit at bottom. Scheduled for sampling in 2023 due to sampling frequency of once every 4 years.	DRO	None
Cannery Loop Unit Pad 3								
MW-1	7/8/2021	7/11/2019	CLU3-MW1-23			Hard hit at bottom. Orange sediment on tape and probe. Scheduled for sampling in 2023 due to sampling frequency of once every 4 years.	DRO, ethylbenzene, 1,2,4-trimethylbenzene, and naphthalene	None
MW-2	7/8/2021	7/8/2021	CLU3-MW2-23	X		Monitoring well straightened because bent approximately 30°. Soft hit at bottom. Mild HC odor.	DRO, ethylbenzene, 1,2,4-trimethylbenzene, and naphthalene	Moderate
MW-3	7/8/2021	7/8/2021	CLU3-MW3-23			Soft hit at bottom. Faint HC odor.	DRO, ethylbenzene, 1,2,4-trimethylbenzene, and naphthalene	Moderate
MW-4	7/8/2021	10/9/2015	CLU3-MW4-23			Soft hit at bottom. More than 3 feet of bio infiltration buildup on bottom and redeveloped. Scheduled for sampling in 2023 due to sampling frequency of once every 4 years.	DRO, ethylbenzene, 1,2,4-trimethylbenzene, and naphthalene	Low
MW-5	7/8/2021	7/8/2021	CLU3-MW5-23		X	Silt on probe. Semi-soft hit at bottom.	DRO, ethylbenzene, 1,2,4-trimethylbenzene, and naphthalene	Low
MW-6	7/8/2021	7/8/2021	Gauge only			Soft hit at bottom. Orange sediment on probe. Sampled every 4 years (next in 2025).	Gauge only	Low
MW-7	7/8/2021	4/14/2008	Gauge only			Semi-soft hit at bottom.	Gauge Only	Low
MW-8	7/8/2021	7/8/2021	CLU3-MW8-23			Collar replaced on well. Hard hit at bottom. Orange sediment on probe.	DRO, ethylbenzene, 1,2,4-trimethylbenzene, and naphthalene	Low
MW-9	7/8/2021	1/23/2008	Gauge only			Silt on probe. Soft hit at bottom.	Gauge Only	Low
MW-10	7/8/2021	4/15/2008	Gauge only			Silt on probe. Soft hit at bottom.	Gauge Only	Low
MW-11	7/8/2021	4/14/2008	Gauge only			No monument casing.	Gauge Only	Low
MW-12	7/8/2021	7/11/2019	CLU3-MW12-23			Hard hit at bottom. Orange sediment on probe. Scheduled for sampling in 2023 due to sampling frequency of once every 4 years.	DRO, ethylbenzene, 1,2,4-trimethylbenzene, and naphthalene	None
MW-13	Decommissioned in 2017.							
MW-C	Not located in 2015 or 2017.							
PZ-1	7/8/2021	7/11/2019	CLU3-PZ1-23			No water in well. Moderate HC odor. Monitor condition for presence/absence of water.	DRO, ethylbenzene, 1,2,4-trimethylbenzene, and naphthalene	Moderate
PZ-2	7/8/2021	7/11/2019	CLU3-PZ2-23			No water in well. Monitor condition for presence/absence of water.	DRO, ethylbenzene, 1,2,4-trimethylbenzene, and naphthalene	Moderate
PZ-3	Abandoned in 2006.							
Kenai Gas Field Pad 14-6								
MW-1	HVE System							
MW-2	HVE System							
MW-3	HVE System							
MW-4	7/1/2021	7/3/2019	KGf146-MW4-23			Bentonite on probe. Hard hit at bottom. Scheduled for sampling in 2023 due to sampling frequency of once every 4 years.	GRO, DRO, RRO, petroleum-related VOCs (including BTEX), and PAHs	Low
MW-5	7/1/2021	9/24/2014	Gauge only			Lock replaced, re-labeled. Bent monument corrected. Soft hit at bottom. Mild organic odor.	Gauge Only	Low
MW-6	7/1/2021	7/4/2019	KGf146-MW6-23			PVC cut down approximately 0.23 feet after gauging. Soft hit at bottom. Scheduled for sampling in 2023 due to sampling frequency of once every 4 years.	GRO, DRO, RRO, petroleum-related VOCs (including BTEX), and PAHs	None
MW-7	7/1/2021	7/2/2021	KGf146-MW7-23	X		Dedicated bladder tubing. Data loggers (Solinst Levellogger and Barologger) removed from well. Grease observed on screws used to secure data logger cables. Soft hit at bottom. Bentonite on probe.	DRO, RRO, benzene, ethylbenzene, 1-methylnaphthalene, 2-methylnaphthalene, naphthalene, 1,2,4-trimethylbenzene, 1,3,5-trimethylbenzene, xylenes, and 1,4-dioxane	High
MW-8	7/1/2021	7/2/2021	KGf146-MW8-23			Dedicated peri tubing. Well scoped and potentially sheared casing observed at approximately 10 feet btoc. Semi-soft hit at bottom. Monitor for potential impacts caused by shearing.	DRO, RRO, benzene, ethylbenzene, 1-methylnaphthalene, 2-methylnaphthalene, naphthalene, 1,2,4-trimethylbenzene, 1,3,5-trimethylbenzene, and xylenes	High
MW-9	7/1/2021	7/2/2021	KGf146-MW9-23			Dedicated bladder tubing. Semi-soft hit at bottom.	DRO, RRO, benzene, ethylbenzene, 1-methylnaphthalene, 2-methylnaphthalene, naphthalene, 1,2,4-trimethylbenzene, 1,3,5-trimethylbenzene, and xylenes	High

Hilcorp Beaver Creek Unit Pad 4, Cannery Loop Unit Pad 3, and Kenai Gas Field Groundwater Monitoring Program
2023 Work Plan Addendum
Kenai Peninsula, Alaska
Table 1: 2023 Well Status

Well ID	Date Well Gauged	Date Well Sampled	Sample ID	QC		2021 Notes	2023 Analysis	Contamination Level (LNAPL, High, Moderate, Low, None)
				Dup	MS/MSD			
MW-10R	7/1/2021	7/3/2019	KGF146-MW10R-23			Plug added. Survey mark added. Stainless steel 1-inch diameter casing. Scheduled for sampling in 2023 due to sampling frequency of once every 4 years.	GRO, DRO, RRO, petroleum-related VOCs (including BTEX), and PAHs	None
MW-11	Decommissioned in 2020.							
MW-12	Decommissioned in 2020.							
MW-13	HVE System							
MW-14	HVE System							
MW-15	HVE System							
MW-16	HVE System							
MW-17	7/1/2021	7/3/2021	KGF146-MW17-23			Collar replaced. 4-inch-diameter casing. Soft hit at bottom.	DRO, RRO, benzene, ethylbenzene, 1-methylnaphthalene, 2-methylnaphthalene, naphthalene, 1,2,4-trimethylbenzene, 1,3,5-trimethylbenzene, and xylenes	Moderate
MW-18	HVE System							
MW-19	Abandoned in 2011.							
MW-20	7/1/2021	7/2/2021	KGF146-MW20-23			4-inch-diameter casing with dedicated peri tubing. Hard hit at bottom. Slight HC odor.	DRO, RRO, benzene, ethylbenzene, 1-methylnaphthalene, 2-methylnaphthalene, naphthalene, 1,2,4-trimethylbenzene, 1,3,5-trimethylbenzene, and xylenes	High
MW-21	HVE System							
MW-22	7/1/2021	7/3/2021	KGF146-MW22-23			4-inch-diameter casing. Soft hit at bottom.	DRO, RRO, benzene, ethylbenzene, 1-methylnaphthalene, 2-methylnaphthalene, naphthalene, 1,2,4-trimethylbenzene, 1,3,5-trimethylbenzene, xylenes, and 1,4-dioxane	High
MW-23	Destroyed and decommissioned in 2022.							
MW-24	7/1/2021	7/3/2021	KGF146-MW24-23			PVC heaved into top of monument and cut down approximately 0.38 feet after gauging. Semi-hard hit at bottom. Faint HC odor.	DRO, RRO, benzene, ethylbenzene, 1-methylnaphthalene, 2-methylnaphthalene, naphthalene, 1,2,4-trimethylbenzene, 1,3,5-trimethylbenzene, and xylenes	High
MW-25	7/1/2021	7/3/2019	KGF146-MW25-23	x		Plug added. Stainless steel 1-inch-diameter casing. Semi-firm hit at bottom. Scheduled for sampling in 2023 due to sampling frequency of once every 4 years.	GRO, DRO, RRO, petroleum-related VOCs (including BTEX), and PAHs	High
MW-26	7/1/2021	7/2/2021	KGF146-MW26-23			Re-labeled. Stainless steel 1-inch-diameter casing with dedicated peri tubing. Slight HC odor.	DRO, RRO, benzene, ethylbenzene, 1-methylnaphthalene, 2-methylnaphthalene, naphthalene, 1,2,4-trimethylbenzene, 1,3,5-trimethylbenzene, and xylenes	High
MW-27	7/1/2021	9/23/2014	Gauge only			Well plug added. 4-inch-diameter casing with dedicated peri tubing. Potentially snapped joint in casing at bottom of well. Monitor for potential impacts caused by shearing.	Gauge Only	None
MW-28	7/1/2021	7/3/2019	KGF146-MW28-23		x	Heaved; PVC cut approximately 0.25 feet after gauging. 4-inch-diameter casing with dedicated bladder tubing. Scheduled for sampling in 2023 due to sampling frequency of once every 4 years.	GRO, DRO, RRO, petroleum-related VOCs (including BTEX), and PAHs	None
MW-29	7/1/2021	7/2/2021	KGF146-MW29-23			4-inch-diameter casing with dedicated bladder tubing. Semi-hard hit at bottom. Slight to moderate HC odor.	DRO, RRO, benzene, ethylbenzene, 1-methylnaphthalene, 2-methylnaphthalene, naphthalene, 1,2,4-trimethylbenzene, 1,3,5-trimethylbenzene, and xylenes	Moderate
MW-30	Decommissioned in 2020.							
MW-31	7/1/2021	9/24/2014	Gauge only			Heaved; PVC cut approximately 0.23 feet after gauging. No lid – replaced cap with locking plug.	Gauge Only	None
MW-32	Abandoned in 2005.							
MW-33	7/1/2021	7/3/2021	KGF146-MW33-23			4-inch-diameter casing. Submerged barologger removed. Sheen and slight HC odor. No solid tone indicating product in well. Soft hit at bottom.	DRO, RRO, benzene, ethylbenzene, 1-methylnaphthalene, 2-methylnaphthalene, naphthalene, 1,2,4-trimethylbenzene, 1,3,5-trimethylbenzene, and xylenes	Moderate
MW-34	7/1/2021	9/23/2014	Gauge only			Locking plug placed, re-labeled, survey mark added. 4-inch-diameter casing with dedicated peri tubing. Soft hit at bottom.	Gauge Only	Low
MW-35	7/1/2021	7/4/2019	KGF146-MW35-23			Survey mark added. 4-inch-diameter casing with dedicated bladder tubing. Soft hit at bottom. Scheduled for sampling in 2023 due to sampling frequency of once every 4 years.	GRO, DRO, RRO, petroleum-related VOCs (including BTEX), and PAHs	Low
MW-36	7/1/2021	7/2/2021	KGF146-MW36-23			4-inch-diameter casing with dedicated bladder tubing. Bentonite on probe. Soft hit at bottom.	DRO, RRO, benzene, ethylbenzene, 1-methylnaphthalene, 2-methylnaphthalene, naphthalene, 1,2,4-trimethylbenzene, 1,3,5-trimethylbenzene, xylenes, and 1,4-dioxane	Moderate
MW-37	7/1/2021	7/4/2019	KGF146-MW37-23			Survey mark added. 4-inch-diameter casing. Soft hit at bottom. Scheduled for sampling in 2023 due to sampling frequency of once every 4 years.	GRO, DRO, RRO, petroleum-related VOCs (including BTEX), and PAHs	Low
MW-38	7/1/2021	9/23/2014	Gauge only			Survey mark added. Dedicated peri tubing. Semi-soft hit at bottom.	Gauge Only	None
MW-39	7/1/2021	9/23/2014	Gauge only			Dedicated peri tubing. Organic sheen observed in surface water surrounding well. Survey mark added.	Gauge Only	Low
MW-40	7/1/2021	7/4/2019	KGF146-MW40-23			Dedicated bladder tubing. Semi-soft hit at bottom. Scheduled for sampling in 2023 due to sampling frequency of once every 4 years.	GRO, DRO, RRO, petroleum-related VOCs (including BTEX), and PAHs	Low
MW-41	7/1/2021	7/2/2021	Gauge and product recovery			Sock in basket in well. Removed sock from basket and replaced. HC odor. Approximately 1.25 gallons product removed. Sock replaced. Sample collected in 2021.	Gauge and product recovery	LNAPL
SW	Surface water	7/16/2021	KGF146-SW1-23 - KGF146-SW8-23	x		Eight surface water collection locations.	BTEX and PAHs	NA
Kenai Gas Field Pad 34-31								
MW-A	Abandoned in 2017.							
MW-C	Decommissioned in 2017.							
MW-E	Decommissioned in 2017.							
MW-1	7/1/2021	7/6/2021	KGF3431-MW1-23			Hard hit at bottom.	DRO, naphthalene, 1,2,4-trimethylbenzene	Moderate
MW-2	7/1/2021	7/5/2021	KGF3431-MW2-23	x		Dedicated bladder tubing. Soft hit at bottom.	DRO, naphthalene, 1,2,4-trimethylbenzene	Low
MW-3	Abandoned in 2000.							
MW-4	7/1/2021	7/5/2021	KGF3431-MW4-23			4-inch-diameter casing with dedicated bladder tubing. Slight chemical/herb odor. Soft hit at bottom.	DRO, naphthalene, 1,2,4-trimethylbenzene	Moderate
MW-5	7/1/2021	7/9/2019	KGF3431-MW5-23	x		4-inch-diameter casing with dedicated bladder tubing. Soft hit at bottom. Scheduled for sampling in 2023 due to sampling frequency of once every 4 years.	DRO, petroleum-related VOCs (including BTEX), and PAHs	Low
MW-6	7/1/2021	7/5/2021	KGF3431-MW6-23			4-inch-diameter casing with dedicated bladder tubing. Hard hit at bottom.	DRO, naphthalene, 1,2,4-trimethylbenzene	Moderate
MW-7	7/1/2021	7/6/2021	KGF3431-MW7-23			4-inch-diameter casing and dedicated bladder tubing. Rust flakes on probe. Hard hit at bottom. Slight chemical odor.	DRO, naphthalene, 1,2,4-trimethylbenzene	Moderate
MW-8	7/1/2021	7/6/2021	KGF3431-MW8-23			Dedicated bladder tubing. Tubing retrieved from well. Soft hit at bottom.	DRO, naphthalene, 1,2,4-trimethylbenzene	Moderate
MW-9	7/1/2021	7/6/2021	KGF3431-MW9-23			4-inch-diameter casing with dedicated bladder tubing. Slight chemical/herb odor. Soft hit at bottom.	DRO, naphthalene, 1,2,4-trimethylbenzene	Moderate
MW-10	7/1/2021	7/5/2021	KGF3431-MW10-23			4-inch-diameter casing with dedicated bladder tubing. Soft hit at bottom.	DRO, naphthalene, 1,2,4-trimethylbenzene	Moderate
MW-11	7/1/2021	7/5/2021	KGF3431-MW11-23			4-inch-diameter casing with dedicated bladder tubing. Hard hit at bottom.	DRO, naphthalene, 1,2,4-trimethylbenzene	Low
MW-12	7/1/2021	7/5/2021	KGF3431-MW12-23			Re-labeled. Semi-soft hit at bottom.	DRO, naphthalene, 1,2,4-trimethylbenzene	Low
MW-13	7/1/2021	Never sampled - gauge only	Gauge only			Re-labeled. Rust flakes on probe. Hard hit at bottom.	Gauge Only	None
MW-14	7/1/2021	Never sampled - gauge only	Gauge only			No monument lid, broken lock hole, no lock, re-labeled. Monument bent. Rust flakes on probe. Semi-hard hit at bottom.	Gauge Only	None

Hilcorp Beaver Creek Unit Pad 4, Cannery Loop Unit Pad 3, and Kenai Gas Field Groundwater Monitoring Program
2023 Work Plan Addendum
Kenai Peninsula, Alaska
Table 1: 2023 Well Status

Well ID	Date Well Gauged	Date Well Sampled	Sample ID	QC		2021 Notes	2023 Analysis	Contamination Level (LNAPL, High, Moderate, Low, None)
				Dup	MS/MSD			
MW-15	7/1/2021	7/10/2019	KGF3431-MW15-23			Monument and concrete heaved approximately 3-inches. Dedicated bladder tubing. Soft hit at bottom. Scheduled for sampling in 2023 due to sampling frequency of once every 4 years.	DRO, petroleum-related VOCs (including BTEX), and PAHs	None
MW-16	7/1/2021	7/10/2019	KGF3431-MW16-23		X	Monument and concrete heaved approximately 2-inches. Dedicated bladder tubing. Soft hit at bottom. Scheduled for sampling in 2023 due to sampling frequency of once every 4 years.	DRO, petroleum-related VOCs (including BTEX), and PAHs	Low
MW-17	7/1/2021	9/2/2008	Gauge only			Re-labeled. Rust on tape. Hard hit at bottom. Slight HC odor.	Gauge Only	Low
Kenai Gas Field Pad 41-7								
MW-1						Decommissioned 2008.		
MW-2						Decommissioned in 2020.		
MW-3						Decommissioned in 2020.		
MW-4						Decommissioned in 2020.		
MW-5						Decommissioned in 2020.		
MW-6						Decommissioned 2008.		
MW-7						Decommissioned 2008.		
MW-8						Decommissioned 2008.		
MW-9						Abandoned in 2008.		
MW-10						Decommissioned in 2020.		
MW-11						Decommissioned in 2020.		
MW-12						Abandoned in 2017.		
MW-13						Decommissioned in 2020.		
MW-14						Abandoned in 2007.		
MW-15	7/1/2021	7/4/2021	KGF417-MW15-23			Heaved. Dedicated bladder tubing. Bentonite on probe. PVC cut approximately 0.21 feet after gauging. Soft hit at bottom.	DRO, benzene, ethylbenzene, 1-methylnaphthalene, naphthalene, 1,2,4-trimethylbenzene, and xylenes	Low
MW-16R	7/1/2021	7/5/2021	KGF417-MW16R-23			Dedicated bladder tubing. Iron staining. Hard hit at bottom.	DRO, benzene, ethylbenzene, 1-methylnaphthalene, naphthalene, 1,2,4-trimethylbenzene, and xylenes	Low
MW-17	7/1/2021	12/2/2009	Gauge only			Heaved. Strong HC odor. PVC cut approximately 0.20 feet after gauging. Hard hit at bottom.	Gauge Only	High
MW-18						Decommissioned in 2008.		
MW-19	7/1/2021	7/4/2021	KGF417-MW19-23			Dedicated bladder tubing. Bentonite on probe. Soft hit at bottom.	DRO, benzene, ethylbenzene, 1-methylnaphthalene, naphthalene, 1,2,4-trimethylbenzene, and xylenes	Moderate
MW-20	7/1/2021	7/4/2021	KGF417-MW20-23			Water in monument casing. Well plug and monument lid and collar replaced. PVC cut approximately 0.28 feet after gauging.	DRO, benzene, ethylbenzene, 1-methylnaphthalene, naphthalene, 1,2,4-trimethylbenzene, and xylenes	Moderate
MW-21						Decommissioned in 2012.		
MW-21R						Decommissioned in 2021.		
MW-21R2	NA	NA	KGF417-MW21R2-23			Installed in 2021 after gauging activities. Sampling data was collected from MW-21R in 2021.	DRO, benzene, ethylbenzene, 1-methylnaphthalene, naphthalene, 1,2,4-trimethylbenzene, and xylenes	Low
MW-22						Decommissioned in 2012.		
MW-22R						Abandoned in 2017.		
MW-23						Abandoned in 2017.		
MW-23R						Decommissioned in 2021.		
MW-23R2	NA	7/16/2021	KGF417-MW23R2-23			Installed in 2021 after gauging activities.	DRO, benzene, ethylbenzene, 1-methylnaphthalene, naphthalene, 1,2,4-trimethylbenzene, and xylenes	High
MW-24						Decommissioned in 2020.		
MW-25						Abandoned in 2021.		
MW-25R	NA	7/17/2021	KGF417-MW25R-23			Installed in 2021 after gauging activities.	DRO, benzene, ethylbenzene, 1-methylnaphthalene, naphthalene, 1,2,4-trimethylbenzene, and xylenes	Low
MW-26						Abandoned in 2017.		
MW-27						Decommissioned in 2021.		
MW-27R	NA	NA	KGF417-MW27R-23		X	Installed in 2021 after gauging activities. Sample data collected from MW-27 in 2021.	GRO, DRO, RRO, benzene, ethylbenzene, 1-methylnaphthalene, naphthalene, 1,2,4-trimethylbenzene, and xylenes	Moderate
MW-28						Abandoned in 2017.		
MW-29	7/1/2021	7/4/2021	KGF417-MW29-23			Heaved. Dedicated bladder tubing. Soft hit at bottom.	DRO, benzene, ethylbenzene, 1-methylnaphthalene, naphthalene, 1,2,4-trimethylbenzene, and xylenes	Low
MW-30						Decommissioned in 2017.		
MW-31	7/1/2021	7/4/2021	KGF417-MW31-23			Dedicated bladder tubing. Hard hit at bottom.	GRO, DRO, RRO, benzene, ethylbenzene, 1-methylnaphthalene, naphthalene, 1,2,4-trimethylbenzene, and xylenes	Low
MW-32						Abandoned in 2020.		
MW-33						Decommissioned in 2021.		
MW-34						Decommissioned in 2017.		
MW-35						Abandoned in 2017.		
MW-36						Decommissioned in 2021.		
MW-36R	NA	7/17/2021	KGF417-MW36R-23			Installed in 2021 after gauging activities.	DRO, benzene, ethylbenzene, 1-methylnaphthalene, naphthalene, 1,2,4-trimethylbenzene, and xylenes	Low
MW-37	7/1/2021	7/4/2021	KGF417-MW37-23			Dedicated bladder tubing. Soft hit at bottom.	DRO, benzene, ethylbenzene, 1-methylnaphthalene, naphthalene, 1,2,4-trimethylbenzene, and xylenes	Low
MW-38	NA	7/18/2021	KGF417-MW38-23		X	Installed in 2021 after gauging activities. Replacement for MW-24 to access the deeper aquifer.	GRO, DRO, RRO, petroleum-related VOCs (including BTEX), and PAHs	High
MW-39	NA	7/17/2021	KGF417-MW39-23		X	Installed in 2021 after gauging activities. Replacement for MW-24 to access the shallower aquifer.	GRO, DRO, RRO, petroleum-related VOCs (including BTEX), and PAHs	Moderate
MW-40	7/1/2021	7/5/2021	KGF417-MW40-23			Stickup height measured above standing surface water. Lock, plug, label added, survey mark added to north side of PVC. Hard hit at bottom.	GRO, DRO, RRO, petroleum-related VOCs (including BTEX), and PAHs	Moderate
SW	Surface water	7/3/2021	KGF417-SW1-23 - KGF417-SW7-23			Seven surface water collection locations.	BTEX and PAHs	NA
Kenai Gas Field 41-18								
MW-A						Decommissioned in 2012.		
MW-C						Abandoned in 2017.		
MW-1						Decommissioned in 2012.		
MW-2	7/1/2021	6/30/2019	KGF4118-MW2-23			Heaved. Damaged monument lid. Loose monument casing. Concrete base shattered. Lock, plug. 4-inch-diameter casing with dedicated bladder tubing. PVC cut approximately 0.20 feet. Semisoft hit at bottom. Scheduled for sampling in 2023 due to sampling frequency of once every 4 years.	DRO, benzene, 1-methylnaphthalene, and naphthalene	Low
MW-3						Decommissioned in 2012.		
MW-3R						Decommissioned in 2021.		
MW-3R2	NA	7/18/2021	KGF4118-MW3R2-23			Installed in 2021 after gauging activities.	DRO, benzene, 1-methylnaphthalene, and naphthalene	Moderate
MW-4	7/1/2021	7/6/2021	KGF4118-MW4-23			Heaved. 4-inch-diameter casing with dedicated bladder tubing. PVC cut approximately 0.21 feet.	DRO, benzene, 1-methylnaphthalene, and naphthalene	Low
MW-5						Decommissioned in 2020.		
MW-6						Abandoned in 2020.		
MW-7						Decommissioned in 2020.		
MW-8R	7/1/2021	9/26/2014	Gauge only			Re-labeled. 1.5-inch-diameter casing with dedicated peri tubing. No protective monument. Reflective stick placed near well for visibility. Trace bentonite on probe. Semi-hard hit at bottom.	Gauge Only	None
MW-9	7/1/2021	7/7/2021	KGF4118-MW9-23			Dedicated bladder tubing. Soft hit at bottom. Biological infiltration observed. Redevelop due to evidence of biological infiltration.	DRO, benzene, 1-methylnaphthalene, and naphthalene	Moderate
MW-10	7/1/2021	9/26/2014	Gauge only			Dedicated peri tubing. Bentonite on probe. Soft hit at bottom.	Gauge Only	Low

Hilcorp Beaver Creek Unit Pad 4, Cannery Loop Unit Pad 3, and Kenai Gas Field Groundwater Monitoring Program
2023 Work Plan Addendum
Kenai Peninsula, Alaska
Table 1: 2023 Well Status

Well ID	Date Well Gauged	Date Well Sampled	Sample ID	QC		2021 Notes	2023 Analysis	Contamination Level (LNAPL, High, Moderate, Low, None)
				Dup	MS/MSD			
MW-11						Decommissioned in 2012.		
MW-11R	7/1/2021	7/7/2021	KGF4118-MW11R-23			1.5-inch-diameter casing with dedicated peri tubing. Semi-firm hit at bottom.	DRO, benzene, 1-methylnaphthalene, and naphthalene	Moderate
MW-12	7/1/2021	6/30/2019	KGF4118-MW12-23			Loose monument lid and collar. Dedicated bladder tubing. Bentonite on probe. Semi-hard hit at bottom. Scheduled for sampling in 2023 due to sampling frequency of once every 4 years.	DRO, benzene, 1-methylnaphthalene, and naphthalene	Low
MW-13						Decommissioned in 2017.		
MW-14	7/1/2021	7/7/2021	KGF4118-MW14-23		X	Dedicated bladder tubing. Monument collar replaced.	DRO, petroleum-related VOCs (including BTEX), and PAHs	Low
MW-15	7/1/2021	7/6/2021	KGF4118-MW15-23	X		Heaved. Dedicated bladder tubing. PVC cut approximately 0.15 feet after gauging. Semi-firm hit at bottom.	DRO, benzene, 1-methylnaphthalene, and naphthalene	Moderate
MW-16	7/1/2021	7/6/2021	KGF4118-MW16-23			1.5-inch-diameter casing with dedicated peri tubing. Firm hit at bottom.	DRO, benzene, 1-methylnaphthalene, and naphthalene	Moderate
MW-17						Decommissioned in 2021.		
MW-17R	NA	NA	KGF4118-MW17R-23			Installed in 2021 after gauging activities. Sample data collected from MW-17 prior to decommissioning.	DRO, benzene, 1-methylnaphthalene, and naphthalene	Low
MW-18						Decommissioned in 2021.		
MW-18R	NA	NA	KGF4118-MW18R-23			Installed in 2021 after gauging activities. Scheduled for sampling in 2023 due to sampling frequency of once every 4 years.	DRO, benzene, 1-methylnaphthalene, and naphthalene	Low
MW-19	7/1/2021	7/7/2021	KGF4118-MW19-23	X		1.5-inch-diameter casing with dedicated peri tubing. No protective monument.	DRO, petroleum-related VOCs (including BTEX), and PAHs	Low
SW	Surface water		KGF4118-SW1-23 - KGF4118-SW5-23	X	X	Five surface water sample collection locations.	BTEX and PAHs	NA

Notes:
Monitoring wells in **red bold** type denote wells that historically contained LNAPL.
Monitoring wells in **gray bold** type denote wells that have been removed from the monitoring program.
Assume monitoring wells have stick-up monuments with 2-inch diameter PVC casing, unless otherwise noted.
Assume monitoring wells are locked, labeled, and have a well plug or cap, unless otherwise noted.
Contamination levels are determined by most recent analytical concentrations available. "LNAPL" = product expected to be present, "High" = more than two exceedances, "Moderate" = two or less exceedances, "Low" = detection(s), "None" = non-detect(s).
° = degrees
BTEX = benzene, toluene, ethylbenzene, and total xylenes
btoc = below top of casing
DRO = total petroleum hydrocarbons (TPH) as diesel-range organics
DUP = duplicate
GRO = TPH as gasoline-range organics
HC = hydrocarbon
HVE = high volume evacuation
ID = identification
LNAPL = light nonaqueous-phase liquid
MS/MSD = matrix spike/matrix spike duplicate
NA = not applicable
PAHs = polycyclic aromatic hydrocarbons
PID = photoionization detector
ppm = parts per million
PVC = polyvinyl chloride
QC = quality control
RRO = TPH as residual range organics
SW = surface water
VOCs = volatile organic compounds

Hilcorp Beaver Creek Unit, Cannery Loop Unit, and Kenai Gas Field Groundwater Monitoring Program
2023 Work Plan Addendum
Kenai Peninsula, Alaska

Table 2: Anticipated 2023 Waste Streams

Waste Stream	Waste Classification	Estimated Quantity	Container	Proper Shipping Name	Disposal	Notes
Liquid IDW – No odor/sheen (purge water, decontamination water)	Non-TSCA/Non-RCRA regulated	237-gallons (BCU: 33-gallons CLU: 24-gallons KGF: 180-gallons)	N/A	Non-hazardous liquid	GAC	GAC-treated water free of sheen will be discharged to a vegetated, upland area of the site at least 100 feet from drinking water sources and surface water. Total purge and decontamination water from each monitoring well will be noted on the field forms.
Liquid IDW - Odor/sheen (purge water, decontamination water)	Exempt	0-gallons	55-gallon drum	Non-hazardous liquid (hydrocarbon odor and/or sheen)	Hilcorp	GAC is anticipated to be sufficient treatment. If three GAC treatment cycles have not removed odor and/or sheen, purge and/or contaminated water will be containerized in a 55 gallon drum provided by Hilcorp, labeled, recorded on the waste-tracking log, and transferred to Hilcorp at KGF Pad 34-31 for storage and subsequent disposal. These sites have sources relating to E&P and are, therefore, exempt.
Product (BCU)	N/A	< 5-gallons	5-gallon bucket with screw-top lid	N/A	Recycle	Volume will be documented and transferred to Hilcorp for recycling in the process stream.
Product (KGF 14-6)	Exempt	< 5-gallons	5-gallon bucket with screw-top lid	Waste Oil	U.S. Ecology	Volume will be documented and transferred to Hilcorp for subsequent offsite disposal through U.S. Ecology.
Sorbent socks	Non-TSCA/Non-RCRA regulated	2 "Oily Waste" bags	Polyethylene "Oily Waste" bags contained in 5-gallon bucket with screw-top lid	Oily Waste	Hilcorp	Used sorbent socks to be disposed of from BCU4 South and KGF Pad 14-6. Bags will be segregated by site, labeled, recorded on the waste-tracking log, and transferred to Hilcorp for storage and subsequent disposal.
Solid Waste	Non-TSCA/Non-RCRA regulated	20 bags	Heavy 42-gallon garbage bags	Non-hazardous waste – solid (general refuse)	Local landfill	General refuse will include nitrile gloves and other expended PPE, paper towels, and disposable tubing. Volume will be documented and transferred to dumpsters in which general refuse can be placed, local landfill, or transfer station.
Spent GAC	Non-TSCA/Non-RCRA regulated	10-gallons	5-gallon bucket with screw top lid	Non-hazardous waste – solid (GAC)	Hilcorp	Hilcorp will facilitate disposal when no longer usable.

Notes:

BCU = Beaver Creek Unit
 CLU = Cannery Loop Unit
 GAC = granular activated carbon
 IDW = investigation-derived waste
 KGF = Kenai Gas Field
 N/A = not applicable
 PPE = personal protective equipment
 RCRA = Resource Conservation and Recovery Act
 TSCA = Toxic Substances Control Act

This page intentionally blank

ATTACHMENT 3
STANDARD OPERATING PROCEDURES

This page intentionally blank

STANDARD OPERATING PROCEDURE

SOP-09

MONITORING WELL INSTALLATION, DEVELOPMENT, AND DECOMMISSIONING

This Standard Operating Procedure (SOP) describes the process for installing, developing, and decommissioning groundwater monitoring wells. This SOP is consistent with Monitoring Well Guidance issued by the Alaska Department of Environmental Conservation (ADEC 2013). Specific monitoring well design and installation procedures depend on project objectives and subsurface conditions and should be discussed in the Work Plan.

Monitoring wells can be installed as long-term monitoring wells, which can be repeatedly sampled over several years, or as temporary well points, which allow for a one-time groundwater sampling event. Following sampling, a temporary well point is usually removed and backfilled in accordance with ADEC regulations.

1. EQUIPMENT AND MATERIALS

The drilling subcontractor will supply all materials and equipment necessary to perform drilling activities and will install monitoring wells in accordance with the Work Plan and as directed.

Temporary well points consist of 1- to 2-inch diameter screened PVC or stainless steel pipe, which can be pre-packed with filter material, or only a slotted screen. Temporary well points can be installed using a drill rig or excavation equipment, or by hand if in unconsolidated material with a shallow water table.

Permanent monitoring wells are installed with either pre-packed or slotted screens, using a drill rig (typically a direct push drill rig or a hollow stem auger).

Equipment and materials that may be needed for monitoring well installation include the following:

- Drill rig or equivalent
- Well casing and screen
- Filter pack materials (silica sand)
- Bentonite
- Surface seal materials (concrete)
- Potable water and/or deionized water
- Weighted tape measure

Equipment and materials that may be needed for monitoring well development includes the following:

- Water level meter or Oil/Water interface probe
- Surge block (with foot valve)
- Submersible pump
- Sprinkler pump (useful for removing large volumes of silt and fine sand laden water)
- Inertial pump and tubing (optional-consider for deep wells greater than 30 feet)
- Disposable polyethylene or Teflon bailers
- 5-gallon buckets
- Graduated cylinder or beaker
- YSI water-quality meter with calibration solutions
- Hach portable turbidity meter
- Potable water and/or deionized water
- Disposable polyethylene tubing

2. WELL INSTALLATION PROCEDURES

This section describes drilling, borehole, casing, well screen, bentonite seal, and monitoring well completion requirements.

2.1 Drilling Requirements

Several drilling methods are available for creating a borehole for well installation. Primary methods include hollow stem auger, direct push, air rotary, mud rotary, and cable tool. The drilling method is selected based on lithology and subsurface characteristics.

All drilling activities will be supervised by a qualified environmental professional. The drill rig will be decontaminated appropriately before it enters and leaves the site in accordance with the *Equipment Decontamination* SOP-15. All leaks will be repaired prior to coming to the site or as soon as they are discovered at the site. The drill rig will not leak any fluids that may enter the borehole or contaminate equipment placed in the hole. The use of rags or absorbent materials to soak up leaking fluids is unacceptable. Spill response equipment will be on site at all times to ensure constant preparedness in the event of a leak.

Drilling mud, synthetic drilling fluids, petroleum or metal-based pipe joint compounds, and other potential contaminants will not be used. Only high yield sodium bentonite clay free of organic polymer additives will be used if drilling mud is needed to stabilize the boring.

Decontamination water must be potable and obtained from a known water source. A construction diagram will be constructed for each monitoring well and the locations and top of casing and ground elevations will be surveyed.

2.2 Borehole Requirements

Borehole diameters should be at least three inches larger than the nominal outside diameter of the casing and well screen. If using a hollow stem auger, the inside diameter of the auger should be at least four inches larger than the nominal outside diameter of the casing and well screen, unless otherwise specified in the approved Work Plan.

The completed monitoring well must be straight to allow passage of pumps and other sampling devices.

2.3 Casing Requirements

The following lists requirements for monitoring well casings:

- All casing will be new, unused, and pre-cleaned (if necessary).
- Glue or solvents will not be used to join casings; casings will be joined only with water-tight flush-joint threads or thermal welds that will not interfere with the planned well use.
- Pop rivets or screws should not be used on casings or other monitoring well components.
- All monitoring wells must conform to the American Society for Testing Materials (ASTM) F-480-06b. The inside diameter should be at least 1.9 inches, except for well points for piezometers and transducers, which can be smaller diameter. Polyvinyl chloride (PVC) is a durable monitoring well material with good chemical resistance (EPA 1991).
- All metal casings will be seamless stainless-steel casings.
- The casing will be straight within the tolerance stated for the borehole.
- A notch in the top of the casing will be cut or marked and used as a measuring point for water levels and survey activities.
- The addition of bentonite surrounding the PVC casing will be visually verified during well installation activities to ensure that bridging is not occurring during withdrawal of the drill string/equipment.

2.4 Well Screen Requirements

The following lists requirements for well screens:

- All requirements that apply to casings will also apply to well screen, except for strength requirements.
- Monitoring wells will not be screened across more than one water-bearing unit. Screens will be factory slotted or wrapped.
- Screen slots will be sized to prevent 90 percent of the filter pack from entering the well, and for wells where no filter pack is used, the screen slot size will be selected to retain 60 to 70 percent of the formation materials outside the screen.
- The bottom of the screen will be capped, and the cap will be joined to the screen by threads.

In most hydrogeologic settings, screen lengths should not exceed 10 feet. The use of shorter well screens (5 feet) may allow for contaminant detection by reducing excessive dilution.

2.5 Filter Pack Requirements

Surrounding the monitoring well intake with materials that are coarser, have a uniform grain size, and have a higher permeability than natural formation material allows the groundwater to flow freely into the well from the adjacent formation, while minimizing or eliminating intrusion by fine-grained materials. Silica sand (10/20 or 12/20) is typically used for the filter pack. The filter pack should extend above the well screen to a length of 20% of the well screen length, but no less than 2 feet (ASTM D5092 2005). The thickness of the filter pack should be at least 2 inches between the borehole and the well screen, but no greater than 8 inches (EPA 1991).

2.6 Seal Requirements

An annular seal should be installed to restrict vertical movement of water or contaminants by sealing the well casing to the adjacent soil formation. The annular seal consists of bentonite chips from the filter pack to approximately 2 feet below the ground surface.

The bentonite seal requirements for wells installed deeper than 12 feet below ground surface are:

- The bentonite seal will consist of at least 2 feet of bentonite between the filter pack and the silica sand used to fill the borehole to the ground surface.
- The bentonite will be hydrated after placement.
- Only 100% sodium bentonite will be used.

The bentonite seal will be terminated 2 feet from the ground surface. The remainder of the annulus will be backfilled using silica sand to minimize bentonite intrusion into the well monument and to promote drainage of water from inside the monument. If the monitoring well is advanced in frozen ground, the annular space between the casing and any permafrost should be sealed to minimize effects on the subsurface thermal regime and to prevent water within the well from freezing.

2.7 Monitoring Well Surface Completion Requirements

Surface completion is not required for temporary well points.

If flush-mounted completions are used, cut the casing approximately six inches below the ground surface and provide a water-tight casing cap to prevent surface water from entering the well. A freely draining surface monument with a bolted cover should be placed over the casing. The surface monument should be placed in well-sorted sand to allow water drainage. If the well is located on a gravel pad, the top of the monument must be completed at least 3 inches below pad grade to protect it from snow removal equipment. The top of the casing must be at least one foot above the bottom of the surface monument. The identity of the well should be permanently marked on the monument lid and the casing cap.

For above-ground monitoring well completions, the well casing will extend 2 or 3 feet above ground surface. Provide a casing cap for each well and shield the extended casing with a steel monument that is placed over the casing and cap, seated in a concrete surface pad. The sleeve diameter should be at least 6 inches greater than the casing diameter. Install a lockable cap or lid on the guard pipe. The well identification should be permanently marked on the casing cap and the monument lid.

Well locations must be designed to ensure groundwater samples and water level measurements characterize discrete stratigraphic intervals. This is achieved by positioning the screened interval relative to the water table elevation.

Well locations and designs must prevent surface contaminants from entering the groundwater as well as leakage of groundwater or contaminants between the stratigraphic intervals in the well bore or along the well annulus. Complete wells above grade to decrease the potential of surface contaminants entering the well.

Install monitoring wells where there is no chance of seasonal inundation by floodwaters, unless the wells have special watertight construction.

2.8 Documentation Requirements

If the well is not direct drilled, log the soil boring in accordance with SOP-01 and ASTM D2488 Unified Soil Classification standards. The *Soil Boring Log* (SOP-01 Attachment 2) must be

completed during installation before leaving the site to ensure all details are captured and are complete and accurate.

Fill out the attached Well Construction Form (Attachment 1) following installation. All fields on the construction form must be completed, or “NA” will be inserted to indicate a field that is not applicable. The required field form sections are outlined below:

- Well designation
- Date of well installation
- Quantity of drilling fluid lost during drilling
- Well volume
- Depth from top of well casing to bottom of well
- Screen length
- Height of well casing above/below ground surface

Monitoring wells will be surveyed within a horizontal accuracy of 1.0 feet and a vertical accuracy of 0.01 foot. The top of casing and ground surface elevations will be surveyed for use as a reference point to determine water-level elevation, sampling depths, and groundwater flow direction. All survey information will be documented in the field logbook.

3. WELL DEVELOPMENT PROCEDURES

Monitoring wells should not be developed for at least 24 hours after installation. Wells can be developed using a submersible pump, peristaltic pump, Waterra foot valve, or a bailer. Waterra foot valves and bailers are more commonly used in wells with smaller water volumes.

Monitoring wells are developed by first purging the well dry, if possible, then allowing the monitoring well to refill with formation water. If the recovery rate by the formation water is too slow, up to one well casing volume of deionized water can be added to the well. The well should be surged vigorously for approximately 10 minutes using either a surge block or bailer. Add more water as necessary. Purge the well dry again to complete the development process (ADEC 2013).

A minimum of three borehole volumes (calculated from the borehole diameter and the length of screen below the water table, corrected for 30 percent porosity of the filter pack) of water, plus twice the volume of water added during drilling and construction will be removed.

If well screens are submerged, the borehole volume is calculated over the interval of the filter pack (length of screen plus 2 feet of added sand above the screen).

After initial surging and pumping, groundwater parameters will be monitored for stability criteria (Table 1). Groundwater parameter stability is reached when three changes between successive readings at approximately 5-minute intervals at a low-flow pumping rate (drawdown less than 0.3 feet) are less than the criteria provided in Table 1. When stabilization is reached, the well is considered developed. If stability cannot be achieved, the well is considered developed when the total volume of water removed from the well equals five borehole volumes plus the volume of drilling fluid lost or potable water added (if fluids were added during well installation or development).

Table 1 Stability Criteria for Low-Flow Purging

Parameter ¹	Units	Recording Precision	Stability Criterion
pH	—	0.01	±0.1
Temperature	°C	0.01	±0.2
Conductivity	µS/cm	1	±3%
Turbidity	NTU	0.1	± 10% or ± 1 NTU (whichever is greater)
Oxidation Reduction Potential (ORP)	mV	1	±10
Dissolved Oxygen (DO)	mg/L	0.1	±10% or 0.3 mg/L (whichever is greater)

Notes:

°C = degrees Celsius

µS/cm = microSiemens per

centimeter NTU = nephelometric

turbidity units mV = millivolts

mg/L=milligrams per liter

Stability criteria from ADEC *Field Sampling Guidance* (ADEC 2022).

¹ Only three parameters are required to stabilize, four when using temperature.

Low-yielding wells are exceptions to the above criteria. Such wells should be purged dry, then either be allowed to recover or be filled with potable water to the static water level for surging. Add water as needed to maintain the water level during surging. Satisfactory recovery is defined as 80 percent of the well volume. After the initial recovery period, such wells will be surged and purged dry again to complete the development process.

Alternative development procedures may be used if they will not affect the ability of the well to provide representative samples. Wells installed with an annular seal must not be developed until 24 hours after well installation to allow annular seal materials to set and cure. ADEC recognizes

that remote site work may make this impractical. The ADEC Project Manager should be contacted for site-specific approval if development is conducted prior to the 24-hour waiting period. Well purge water should be discharged and treated as needed in accordance with the project-specific Work Plan. The following details should be recorded on the Well Development Form (Attachment 2):

- Date of development
- Static water level before and after development
- Depth from top of well casing to top of sediment inside well, before and after development, if present
- Physical characteristics of removed water, including changes during development in clarity, color, particulates, and odor
- Type and size/capacity of pump and/or bailer used
- Pumping rate
- Recharge rate
- Quantity of water removed and time of removal
- Parameter readings, including pH, temperature, conductivity, turbidity, ORP, and DO (if stabilized)

4. WELL DECOMMISSIONING PROCEDURES

The purpose of decommissioning is to protect the aquifer. Monitoring wells and temporary well points should be decommissioned as soon as ADEC has determined the wells are no longer needed. This SOP is consistent with the decommissioning section of the *Monitoring Well Guidance* issued by the Alaska Department of Environmental Conservation (ADEC 2013). Specific monitoring well decommissioning procedures depend on project objectives and subsurface conditions, and must be presented in the Work Plan. ADEC approval of the Work Plan is required prior to decommissioning wells. Common well decommissioning procedures include:

1. Knock the bottom of the screen out with a steel drill rod/ pipe, which allows the well to be used as a tremie pipe.
2. Remove the well casing and screen until the screened interval is above the groundwater interface. This allows the material surrounding the well to collapse into the borehole. Keep a 1:1 ratio when pulling out the screen (i.e., if you have a 10' screen, pull the well out 10').

3. After the casing is withdrawn above the groundwater interface, add some bentonite chips to the well. Withdraw the casing further and continue adding bentonite chips. Continue this iterative process (pull the casing, fill the borehole, pull the casing, fill the borehole) to within 2 feet of the ground surface.
4. If the well is shallow, add water to hydrate the bentonite chips. Add additional bentonite chips as necessary to seal the well to within 2 feet of the ground surface.
5. If the well is deep, use a grout pump to place a bentonite slurry in the well. The use of the grout pump will ensure a complete seal of the borehole and minimize the potential for bridging.
6. If the well is in a confined aquifer, bentonite chips should be placed within the confining stratum.
7. Fill the remaining 2 feet of the borehole with sand or gravel and restore the site.
8. Record decommissioning procedures.

If the well casing and screen cannot be removed at the time of decommissioning, and it is known that the well construction included a competent annular seal of bentonite chips surrounding the well casing, the screen should be filled with sand and the casing should be completely sealed in place with bentonite chips up to the casing cutoff point located near the ground surface.

If the monitoring well is damaged, broken, filled, or plugged with soil or other extraneous material preventing successful decommissioning efforts by the methods described above, decommissioning can be achieved by re-drilling the monitoring well. The PVC casing and well screen may be destroyed by re-drilling the original borehole to the total depth of the well. When the auger is at the bottom of the well, bentonite chips should be added continuously as the auger is carefully removed.

5. REFERENCES

Alaska Department of Environmental Conservation (ADEC). 2013. Monitoring Well Guidance. September.

ADEC. 2022. Field Sampling Guidance. January.

American Society of Testing Materials (ASTM). 2009. Standard Practice for Description and Identification of Soils (Visual-Manual Procedure. D2488. West Conshocken, Pennsylvania. July.

Environmental Protection Agency (EPA) .1991. Handbook of Suggested Practices for the Design and Installation of Ground-Water Monitoring Wells, Office of Research and Development. March.

EPA Region 4. 2008. Design and Installation of Monitoring Wells, Science and Ecosystem Support Division. February.

ATTACHMENTS

Attachment 1: Well Construction Form

Attachment 2: Well Development Form

Attachment 1: Well Construction Forms

This page intentionally blank

PROJECT NUMBER

WELL ID

FLUSH MOUNT WELL COMPLETION DIAGRAM

PROJECT/CLIENT:

LOCATION :

DRILLING CONTRACTOR:

DRILLING METHOD AND EQUIPMENT USED:

WATER LEVEL:

START :

END :

LOGGED BY:

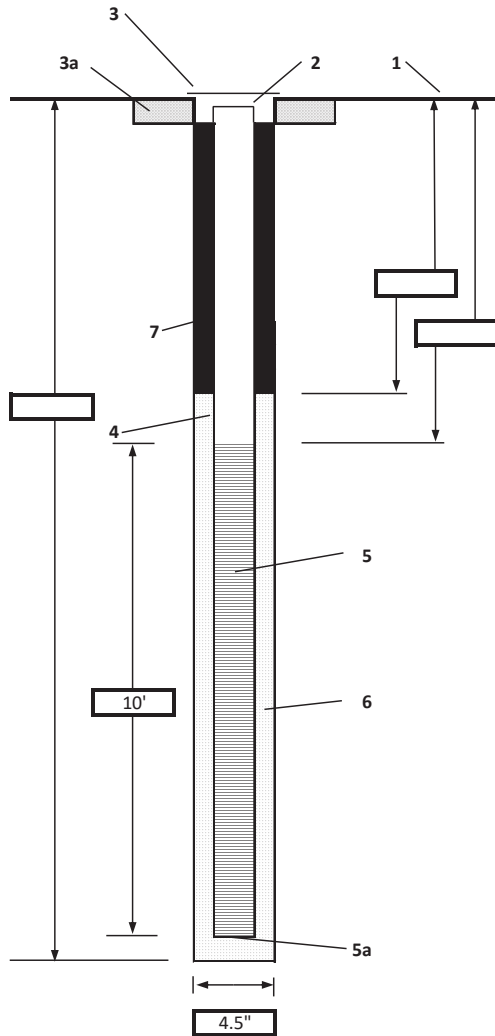

1- Ground elevation at well	TBD
2- Top of casing elevation	TBD
3- Wellhead protection cover type	8" x 12" steel monument
a) concrete pad dimensions	20" diameter
4- Dia./type of well casing	2" Schedule 40 PVC
5- Type/slot/size of screen	2" Schedule 40 PVC 0.010" screen
a) End cap	2" D x 4" L threaded end cone
6- Type of screen filter	Premier Colorado Silica Sand 12/20
7- Type of seal	Baroid Casing Seal
Development method	See Development Sheet
Development time	See Development Sheet
Estimated purge volume	See Development Sheet

Comments _____

PROJECT NUMBER

WELL ID SHEET 1 OF 1

RISER WELL COMPLETION DIAGRAM

PROJECT/CLIENT: LOCATION :
 DRILLING CONTRACTOR:
 DRILLING METHOD AND EQUIPMENT USED:
 WATER LEVEL: START : END : LOGGED BY:

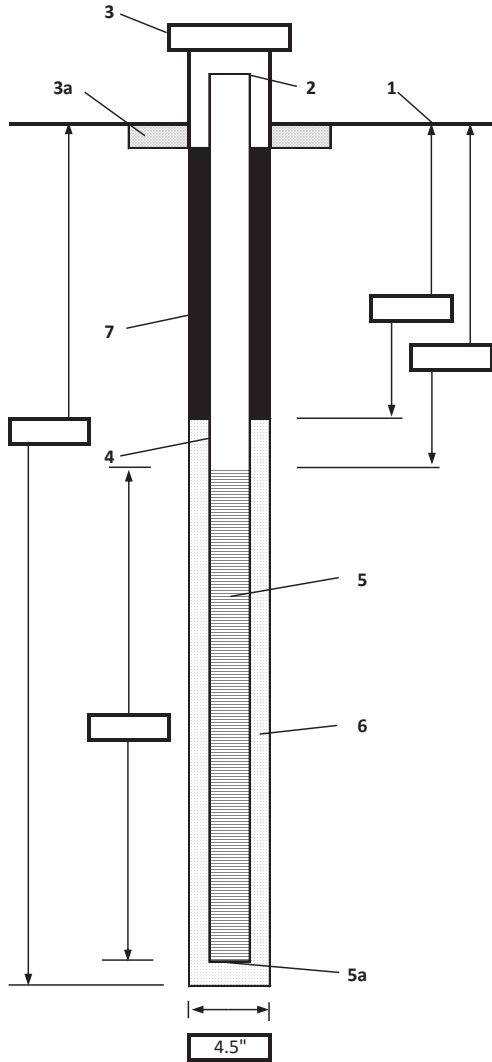

1- Ground elevation at well	_____	TBD
2- Top of casing elevation	_____	TBD
3- Wellhead protection cover type	_____	8" x 48" steel riser
a) concrete pad dimensions	_____	20" diameter
4- Dia./type of well casing	_____	2" Schedule 40 PVC
5- Type/slot/size of screen	_____	2" Schedule 40 PVC 0.010" screen
a) End cap	_____	2" D x 4" L threaded end cone
6- Type of screen filter	_____	Premier Colorado Silica Sand 12/20
7- Type of seal	_____	Baroid Casing Seal
Development method	_____	See Development Sheet
Development time	_____	See Development Sheet
Estimated purge volume	_____	See Development Sheet
Comments	_____	

Attachment 2: Well Development Form

This page intentionally blank

STANDARD OPERATING PROCEDURE

SOP-10

GROUNDWATER GAUGING, MONITORING, AND SAMPLING

This Standard Operating Procedure (SOP) describes field procedures for collecting representative groundwater samples from monitoring wells and temporary well points. This SOP is prepared in accordance with the Alaska Department of Environmental Conservation (ADEC) Field Sampling Guidance (ADEC 2022) and Environmental Protection Agency (EPA) Low-flow (Minimal Drawdown) Ground-Water Sampling Procedure (EPA 1996). Refer to the Work Plan for specific sampling locations and analytes.

1. EQUIPMENT AND MATERIALS

Equipment and supplies utilized during groundwater sampling may include the following:

- PPE (safety glasses and nitrile gloves, other PPE as required by site conditions)
- RAE Systems MiniRAE photoionization detector (PID), if needed to check vapor emitted from well casing
- Water level meter with audible alarm and a cable marked in 0.01 foot increments
- Oil-water interface probe (if LNAPL is suspected)
- Decontamination equipment (deionized water, Alconox, 5-gallon bucket, paper towels)
- YSI 556 Multi-Probe System and cable
- Flow cell/ sensor guard/ calibration cups
- Calibration solutions for YSI (pH 4, 7, and 10, ORP, and conductivity)
- Discharge lines/silicone tubing and fittings
- Turbidity diverter
- Hach 2100P Portable Turbidity Meter or equivalent
- Graduated cylinder or beaker
- Graduated buckets
- Submersible (stainless steel centrifugal Proactive Monsoon pump with low-flow controller, or equivalent), bladder pump, or peristaltic pump depending on type of contaminants present and well depth

- Disposable Teflon bailers and twine
- Tubing (Teflon-lined and silicone)
- Camera
- Logbook, weatherproof pen, sharpie, etc.
- Groundwater Sampling Forms
- Sample labels
- Sampling containers and packing materials

2. FREE PRODUCT, WATER LEVEL, AND TOTAL DEPTH GAUGING

PROCEDURES

The depth to free product (if present) and the depth to groundwater will be measured with an oil/water interface probe. Interface probes provide distinct responses when immersed in nonconductive product or conductive water.

If the well is sealed with an airtight cap, allow time for the pressure to equilibrate after the cap is removed. Before taking measurements, locate the reference point on the well casing. Typically, the reference point is marked with a permanent surveyor's reference mark, such as a small notch cut into the casing or a permanent ink mark at the top of the casing (TOC). If no reference mark is present, mark the north side of the monitoring well casing and collect water level measurements from this mark. Measure the depth to water (DTW) using the following procedures:

1. Open the monitoring well lid and remove the well plug. If air monitoring is warranted to determine the presence of volatile organic compounds (VOCs), a PID (MiniRAE 2000 or similar) will be used to monitor the following:
 - Ambient conditions prior to removing the well plug and opening the well lid and plug.
 - Ambient conditions in the breathing zone when opening the well or removing the well plug.
 - Headspace immediately after removing the well plug.
 - Breathing zone after the well plug has been removed.
2. With the water level meter or interface probe switched on, slowly lower the probe down the monitoring well until the probe contacts the groundwater or LNAPL surface, as indicated by the audible alarm. Do not let the probe free-fall down the well. Always hold on to the meter's reel handle.

3. Raise the probe out of the water or LNAPL until the audible alarm stops. Continue raising and lowering the probe until a precise level is determined within 0.01 foot.
4. If LNAPL is present in the well, measure and record the depth from the top of casing reference point to the top surface of the LNAPL layer. The oil-water indicator probe alarm will sound a continuous tone when LNAPL is detected.
5. Continue to lower the probe until the meter indicates groundwater. The alarm will emit an intermittent beep when water is detected. Record the DTW measurement from the TOC reference point to the static groundwater level.
6. Measure the total well depth (TD) by lowering the probe to the bottom of the well. Turn off the alarm and slowly lower the water level meter until the cable goes slack. Do not let the probe free-fall down the well. Always hold on to the meter's reel handle. Record the TD from the TOC reference point. Gently raise and lower the water level meter probe to tap the bottom of the well until a precise well depth is determined within 0.01 foot.
7. Record the DTW and TD measurements in the field logbook or on the Groundwater Sampling Form (Attachment 1).
8. Decontaminate water level meters and interface probes between monitoring wells in accordance with SOP-15 to avoid cross-contamination.
9. For later development of potentiometric maps, measure DTW and TD in all monitoring wells at a site as quickly as practicable.

3. WATER QUALITY MONITORING AND SAMPLING PROCEDURES

Submersible, bladder, or peristaltic pumps are typically used for purging and sampling with pump selection dependent on the target analytes and water depth. Prior to sampling, monitoring equipment must be calibrated. Monitoring wells are then purged until stabilization is reached for wells with adequate recharge. Water quality parameters will be monitored during purging using a YSI 556 water quality meter and a portable turbidity meter. Turbidity meters, such as the Hach Model 2100P Portable Turbidimeter, measure turbidity from 0.01 to 1000 NTU in automatic range mode with automatic decimal point placement. Note that different instrument models exist, and the appropriate operation and procedures manual should be referenced prior to use.

For sample collection of VOCs, a peristaltic pump should not be used unless approval from ADEC is obtained prior to sample collection. If a peristaltic pump is used for sample collection, VOC samples should be collected using Hydrasleeve groundwater samplers. Wells that contain free product are not typically sampled.

3.1 Monitoring Equipment Calibration Procedures

Prior to initiating purging, bump checks must be conducted for the YSI 556 and turbidity meter. Bump check readings should be documented on their respective forms (Attachments 2 and 3). Bump check the YSI for pH, conductivity, ORP, and DO. Always bump check pH with a 3-point method to account for the full pH range. If any reading is outside the expected calibration standard, the equipment will be re-calibrated. If the instrument remains outside the expected calibration standard, the instrument will be removed from project use and replaced as soon as practicable. Flag any data recorded from a meter with suspected calibration issues on the applicable field forms. Store the YSI probe according to manufacturer instructions in pH 4.0 solution. Do not store the probe in deionized.

Calibrate or bump check the turbidity meter daily prior to use and record the results on the calibration form (Attachment 3). Calibration standards are provided with the meter.

3.2 Purging Procedures

Purging is the process by which stagnant water is removed from a well prior to sample collection to allow groundwater from the adjacent formation to enter the well. This allows for collection of a sample representative of actual aquifer conditions.

Purging will be conducted in accordance with EPA and ADEC low-flow sampling guidelines (EPA 1996, ADEC 2022). Monitoring wells will be purged, at minimum, the equivalent of three times the well volume, or until three of the four stabilization parameters (specific conductance, oxidation reduction potential [ORP], pH, and dissolved oxygen [DO]) have stabilized. If using temperature for stabilization, four of the five stabilization parameters should be stabilized. The volume of water purged from each well will be calculated based on the length of the water column and well casing diameter. The formula to calculate the water volume to be purged is as follows:

Purge volume = 3 well casing volumes = (total depth of casing (ft) – depth to groundwater) * gallons per linear foot * 3. Refer to the Groundwater Sampling Form for the various gallons per linear foot based on the casing diameter of the well.

$$V = *0.041D^2(d_2-d_1)$$

V= Volume in gallons

D = Inside diameter of well casing in inches

d₂ = Total depth of well in feet

d₁ = Depth to water surface in feet

*0.041 is based on a 1-inch diameter well.

The general procedures for collecting water quality parameters during purging using a YSI 556 with a flow cell include the following:

1. Lower the pump (submersible or bladder) or tubing (peristaltic) to the target depth below the static water level. Record the depth of the pump on the Groundwater Sampling Form (Attachment 1). For wells screened across the groundwater interface, a pump intake of 1.0 to 2.0 feet below the static water level is typically used. For wells with submerged screens, set the pump intake at the middle of the screened interval.
2. Allow the purge water to visually clear before connecting the flow cell to prevent sediment from building up in the bottom of the flow cell.
3. After the water visually clears, place the YSI 556 probe into the flow cell. Temporarily turn off the pump and connect the water line to the connector at the bottom of the flow cell. Connect a silicone discharge tube to the effluent connector at the top of the flow cell and place the other end of the discharge tube into a graduated 5-gallon bucket.
4. Turn on the pump and allow the flow-thru cell to completely fill with water.
5. Measure and adjust the flow rate. The flow rate should not exceed 500 mL per minute for low flow purging and drawdown should remain stable at less than 0.3 feet, when possible.
6. Measure and record DO, ORP, conductivity, pH, turbidity, temperature, and the depth to groundwater every 3-5 minutes until the well is stabilized or until three well volumes have been purged. A minimum of three measurements should be taken and recorded on the Groundwater Sampling Form (Attachment 1). A well is considered stable when three of the parameters in Table 1 meet the stability criterion (four if using temperature):

Table 1 Stability Criteria for Low-Flow Purging

Parameter ¹	Units	Recording Precision	Stability Criterion
pH	-	0.01	±0.1
Temperature	°C	0.01	±0.2°C or ±3%
Conductivity	µS/cm	1	±3%
Turbidity	NTU	0.1	± 10% or ± 1 NTU (whichever is greater)
ORP	mV	1	± 10
DO	mg/L	0.1	± 10% or 0.2 mg/L (whichever is greater)

Note:

Stability criteria from ADEC Field Sampling Guidance (ADEC 2022).

¹ Only three parameters are required to stabilize, four when using temperature.

Turbidity readings consistently below 10 nephelometric turbidity units (NTU) are considered stabilized.

7. To measure turbidity, collect a representative sample in the clean glass vial provided with the turbidity meter. For sediment laden wells, use a diverter to collect the turbidity sample directly from the water line, bypassing the flow cell. Fill to the line marked on the vial (approximately 15 mL), taking care to handle the vial by the top. Cap the vial. Wipe the vial with a paper towel to remove water spots and fingerprints. Turn the instrument on and place it on a flat sturdy surface. Insert the vial into the instrument compartment so the diamond or orientation mark aligns with the raised orientation mark in front of the vial compartment. Press READ and the result will show in nephelometric turbidity (NTU).
8. Once the well has met the stabilization criteria, disconnect the water line from the flow cell and proceed with sample collection directly from the water line.
9. For low yielding wells that cannot be stabilized without substantial draw down, purge the well dry and allow the well to recharge to approximately 80% of its pre-purge volume before collecting analytical samples.

3.3 Groundwater Sample Collection Procedures

Samples should be collected using the following steps:

1. When purging is complete, disconnect the flow through cell from the tubing.
2. Don new nitrile gloves prior to handling sample bottles.
3. Collect samples in the appropriate containers (with preservatives if required by the analytical methods). Begin with volatile sample collection. Slowly fill the 40 mL vials to prevent splashing and entrainment of air bubbles. Reduce the pumping rate, if necessary, to control the flow rate. Care should be taken to avoid touching the mouth of the discharge line, the top of the sample bottle, the inside of the cap, or the Teflon septum. A septum that falls out of the cap onto the ground cannot be used. The vial will be filled completely so that a convex meniscus forms. The cap will then be secured and the bottle inverted, tapped firmly, and checked for the presence of air bubbles. Analytical results will be compromised if air is trapped in the sample container.
4. After volatile sample containers are filled, proceed with filling non-volatile sample containers. Note that these do not need to be filled all the way to the cap like the volatile sample containers and space should be left so the groundwater sample does not touch the cap.
5. Ensure field Quality Control (QC) sample requirements included in the Work Plan are followed. QC samples may include trip blanks, equipment blanks, field duplicates, and the collection of additional sample volumes for the laboratory's quality control (matrix spike

and matrix spike duplicates). The frequency of QC sample collection will be outlined in the Work Plan. Refer to SOP-14 QC procedures.

6. Once sample collection is complete, turn off the sample pump and remove the tubing and pump from the well. Decontaminate all reusable down well sampling equipment in accordance with SOP-15 and pack up equipment for transport to next well.
7. Handle purge water in accordance with the Work Plan or Waste Management Plan.
8. Chain-of-custody procedures and sample management should be conducted in accordance with SOP-17.

4. POTENTIAL INTERFERENCES

Two potential interferences associated with groundwater sampling are cross-contamination and a lack of sample representation due to improper well purging or stabilization. To prevent cross-contamination between wells, dedicated tubing will be placed in each well and all non-disposable equipment that may directly or indirectly contact samples, will be decontaminated prior to use in another well. Equipment decontamination will be performed in accordance with SOP-15. To ensure that representative conditions within the aquifer are captured during sample collection, purging will be conducted at a rate that produces minimal drawdown until water quality parameters have stabilized or three well volumes have been removed or as described in Section 3.2.

5. REFERENCES

Alaska Department of Environmental Conservation (ADEC). 2022. Field Sampling Guidance. January.

Environmental Protection Agency (EPA). 1996. Low-Flow (Minimal Drawdown) Ground-Water Sampling Procedures. EPA/540/S-95/504. R.W. Puls and M.J. Barcelona. April.

Hach Company. 2008. Hach Portable Turbidity Meter Model 2100P Instrument and Procedure Manual. April.

YSI Incorporated. 2009. YSI 556 Multi Probe System Operations Manual. August.

ATTACHMENTS

Attachment 1: Groundwater Sampling Form

Attachment 2: YSI Calibration Form

Attachment 3: Turbidity Meter Calibration Form

This page intentionally blank

Attachment 1: Groundwater Sampling Form

This page intentionally blank



Groundwater Sampling

Submitted Date:

Project Information		
Project Name	Client	Site

Location Information				
Well ID	Event Date	Weather		Ambient Temperature (°F)
		Overcast ☁		39
Well Condition				
Good		Nathaniel Gingery, Kyle Therrien		Ambient: Breathing Space: Down Well:
Well Diameter	Well Stickup Height	Current Depth to Water	Total Well Depth	Height of Water Column
in	ft ags	t btoc	ft btoc	
Tubing Type	Pump Depth	Volume of Water in Well	Minimum Purge Volume	Maximum Purge Volume
	ft btoc	gal	gal	gal
Parameter Reading Equipment	Pump Type	Pump Start Time	Pump End Time	Total Volume Purged
YSI, Turbidimeter	Bladder Pump Recharge: Discharge: Cycle:			gal
Stability was reached by:				

Stability Readings										
Reading Time	Depth to Water (ft btoc)	Draw Down (ft)	Volume Purged (mL)	Flow Rate (mL/min)	Temperature (°C) ±3%	pH ±0.1	Conductivity (µS/cm) ±3%	ORP (mV) ±10mV	DO (mg/L) ±10%	Turbidity (NTU) ±10% or ±1 NTU

Sample Information				
Sample ID	Sample Time	Sample Date	QC Type	
Method				
Bottle				
Preservative				

Comments

Site Photos

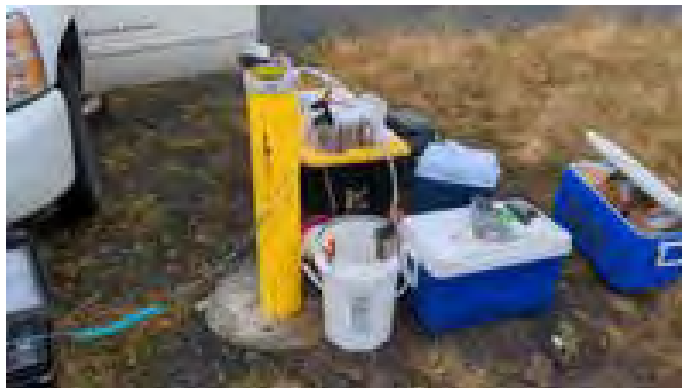

Photo Name

Photo Direction

This page intentionally blank

Attachment 2: YSI Calibration Form

This page intentionally blank

Attachment 3: Turbidity Meter Calibration Form

This page intentionally blank

STANDARD OPERATING PROCEDURE

SOP-11

SURFACE WATER SAMPLING

This Standard Operating Procedure (SOP) describes field procedures for collecting surface water samples from stagnant and flowing water bodies for field screening and analytical analysis. This SOP is prepared in accordance with the Alaska Department of Environmental Conservation (ADEC) Field Sampling Guidance (ADEC 2022). Refer to the Work Plan for specific sampling locations and analytes.

1. EQUIPMENT AND MATERIALS

Equipment and supplies utilized during groundwater sampling may include the following:

- PPE (nitrile gloves, safety glasses, waders, etc.)
- Sampling device (peristaltic pump, submersible pump, bailer, bottle, automatic sampler)
- Extension pole
- Tubing if pump is used
- Battery for pumps
- Nylon rope or steel cable
- Decontamination equipment (deionized water, Alconox, 5-gallon bucket, paper towels)
- YSI 556 Multi-Probe System and cable
- Calibration solutions for YSI (pH 4, 7, and 10, ORP, and conductivity)
- Hach 2100P Portable Turbidity Meter or equivalent
- Camera
- Logbook, weatherproof pen, sharpie, etc.
- Sample labels
- Laboratory-supplied sample containers, preservatives, labels, custody seals, and temperature blanks
- Survey stakes, flags, buoys, or anchors to mark sample locations

- Zip-top plastic bags
- Gel ice
- Trash bags
- Global positioning system (GPS)

2. SURFACE WATER SAMPLING PROCEDURES

Surface water can be collected from just beneath the water surface, mid-water column, or just above the bottom. Target sample depths will be specified in the project Work Plan. Surface water samples can be collected using a variety of methods and sampling devices. The most common collection methods involve either hand collection or collection using sampling equipment. For hand collection, a clean, unpreserved sample bottle or bailer is used to collect water from the water body. Care must be exercised if using this technique to minimize sediment and water disturbance. A method used to collect undisturbed samples involves using a peristaltic or submersible pump to remove water from a target depth within the waterbody. The tubing or pump can be affixed to an extension pole and deployed from shore for nearshore samples to prevent sediment disturbance from impacting the sample. Sample collection procedures for sampling by hand include the following:

1. Don new nitrile gloves and other PPE
2. Decontaminate reusable sample equipment
3. Wade into the water to the target sample location. Take care to avoid disturbing sediment from the bottom. If the water is flowing, stand downstream of the sample collection location and allow any disturbed sediment to be flushed out before beginning sample collection.
4. Collect sample by lowering a clean, unpreserved 1-liter sample bottle, facing neck down, into the water body to the target depth.
5. Once at the target depth, turn the bottle until the neck is facing slightly upwards with the mouth facing into the current. Remove the bottle cap and allow the bottle to fill with water.
6. Cap the bottle while underwater and remove the bottle from the water body.
7. Decant the sample into the appropriate laboratory sample containers.
8. Repeat the above steps if additional sample volume is needed to fill the laboratory sample containers. Fill volatile sample containers first followed by non-volatile containers.

9. Mark survey location with lathe or other marker for later surveying or survey sample location immediately using GPS.
10. Manage samples in accordance with the procedures in SOP-17.

Sample collection procedures for sampling using a pump or sampler include the following:

1. Don new nitrile gloves and other PPE
2. Decontaminate reusable sample equipment
3. Deploy the tubing or sampler to the target location and depth. If using a sampler, deploy it in the closed position and only open the sampler when it is in place at the target depth.
4. If using a pump, once the tubing is deployed at the target depth, turn on the pump and allow water to flush through the tubing. Once the tubing is flushed and the water is running clear, begin filling laboratory sample containers. Volatile sample containers should be filled first followed by non-volatile containers. Note that use of a peristaltic pump is not permitted for volatile sample collection, unless pre-approved by ADEC.
5. Mark survey location with lathe or other marker for later surveying or survey sample location immediately using GPS.
6. Manage samples in accordance with the procedures in SOP-17.

Water quality parameters may be monitored before or after sampling (as specified in the Work Plan) using a YSI 556 water quality meter and a portable turbidity meter. If sediment disturbance is a concern, these readings should be collected after collecting the analytical surface water sample. Calibration should be performed on the instruments prior to use in accordance with the procedures detailed in SOP-10. The YSI 556 probe should be placed in the probe sensor guard and lowered to the target sample depth in the surface water body. After allowing the instrument to equilibrate, readings should be recorded in the field logbook. Water for turbidity analysis should be collected using the selected sampling device (bottle, tubing, sampler, etc.) and transferred into the vial provided with the turbidimeter for reading.

3. REFERENCES

Alaska Department of Environmental Conservation (ADEC). 2022. Field Sampling Guidance. January.

Hach Company. 2008. Hach Portable Turbidity Meter Model 2100P Instrument and Procedure Manual. April.

National Oceanic and Atmospheric Administration and Research Planning, Inc. Guidelines for Collecting High Priority Ephemeral Data for Oil Spill in the Arctic in Support of Natural Resource Damage Assessment. 2014. September.

YSI Incorporated. 2009. YSI 556 Multi Probe System Operations Manual. August.

STANDARD OPERATING PROCEDURE

SOP-14

QUALITY CONTROL SAMPLES

The purpose of this Standard Operating Procedure (SOP) is to direct field personnel in the requirements necessary for collecting field quality control (QC) samples from certain matrixes. Field QC samples are collected to ensure the reliability and validity of field and laboratory data, and include field duplicates, matrix spike and matrix spike duplicates (MS/MSD), temperature blanks, trip blanks, and equipment blanks.

1. SAMPLING PROCEDURES

The following sections describe the procedures for collecting QC samples.

1.1 Field duplicate

Field duplicates are collected to determine whether sample matrix heterogeneity, contaminant distribution, or sample collection methods affect analytical precision. The field sampler ensures that primary and duplicate samples are effectively identical by collecting the samples from the same location, at the same time, with the same techniques, and from the same matrix. Non-volatile samples should be homogenized in a metal bowl or sealable zip-top bag prior to sample collection. Volatile samples should not be homogenized to minimize loss of volatile constituents; however, an effort should be made to collect samples from the same matrix and part of the sample interval.

At a minimum, one blind field duplicate should be collected per day and per 10 samples for each analytical method and matrix for offsite laboratory analysis. In some cases, such as when only one monitoring well per day can be sampled because of low yielding groundwater, it is not feasible to achieve the one field duplicate per day requirement. If anticipated prior to conducting project work, these site-specific deviations should be included in the Work Plan. If multiple sample coolers are shipped together, an effort should be made during sample packaging to include a duplicate in each cooler.

Field duplicates are submitted as blind samples with a unique sample number and collection time to the approved laboratory for analysis (ADEC 2022). A duplicate sample collection time of one hour before the primary sample time is recommended to ensure there are no holding time issues.

1.2 Matrix Spike and Matrix Spike Duplicate

MS/MSD samples are collected to evaluate the precision and accuracy of laboratory procedures in the project sample matrix. The MS/MSD compound is added at the laboratory. This sample is collected at the same time as the primary sample using the same procedure, equipment, and

type of container. The MS/MSD sample should be labeled the same as the primary sample with a matching sample identification and time denoted on the chain-of-custody form to ensure that the project MS/MSD pair is used in the laboratory report. The MS/MSD should be noted in the QC column of the chain-of-custody. At a minimum, the frequency of MS/MSD samples collected is one for each analytical batch. Note that the analytical laboratory often batches samples in the same cooler together for shipments containing multiple coolers, so an effort should be made during sample packaging to include an MS/MSD in each cooler. The MS/MSD evaluation process is specified in the Quality Assurance Project Plan (QAPP).

1.3 Temperature Blank

A temperature blank must be included in each sample cooler. A temperature blank is measured by the laboratory to verify and document that the cooler temperature is received between 0 and 6 degrees Celsius (°C). Temperature blanks consist of plastic bottles filled with water, typically prepared by the laboratory. Once shipments are received by the laboratory, the temperature is recorded on the chain-of-custody to document that preservation requirements were met.

1.4 Trip Blanks

Trip blanks must accompany volatile samples, including gasoline range organics and volatile organic compounds. Trip blanks are prepared by the laboratory and are used to establish that the sample has not been contaminated by external sources during transport to and from the field. Trip blanks are samples of reagent-grade water, properly preserved in a controlled environment by the laboratory prior to field mobilization. Trip blanks are kept with the sample containers throughout the sampling process and returned to the laboratory with the analytical samples. One trip blank must accompany each cooler containing volatile samples. All trip blanks must be labeled and included on the chain-of-custody. Trip blank sample times will be recorded as 0800. The trip blank evaluation process is specified in the QAPP.

1.5 Equipment Blanks

Equipment blanks may be used to evaluate the effectiveness of decontamination procedures. The equipment rinsate blank is collected by pouring or pumping deionized water onto or into the sampling equipment after the equipment has been decontaminated, and then collecting the rinsate water for analysis of an analytical suite identical to that performed for the associated sample(s). The required equipment rinsate blank collection frequency and evaluation process are specified in the QAPP. Decontamination procedures must be performed in accordance with SOP-15 Equipment Decontamination.

2. REFERENCES

Alaska Department of Environmental Conservation (ADEC). 2022. Field Sampling Guidance. January.

This page intentionally blank

STANDARD OPERATING PROCEDURE

SOP-15

EQUIPMENT DECONTAMINATION

The purpose of this Standard Operating Procedure (SOP) is to describe the procedures for decontamination of reusable equipment.

1. EQUIPMENT AND MATERIALS

Equipment and materials utilized for decontamination may include:

- Level D Personal Protective Equipment (nitrile or rubber gloves, safety glasses, safety toed boots, hard hat and safety vest if decontaminating drilling or heavy equipment)
- Hand tools for bulk contamination removal (shovels, brooms, etc.)
- Liquinox or Alconox
- Spray bottles, or pump sprayer
- Pressure washer/steam cleaner (for larger equipment such as augers)
- Potable water
- Distilled or deionized water
- Bristle brushes
- Plastic tubs
- Plastic sheeting
- Department of Transportation (DOT)-approved, 5-gallon buckets with screw top lids
- DOT-approved, 55-gallon open-top drums
- Contractor-grade plastic bags
- Paper towels

2. DECONTAMINATION PROCEDURES

Reusable sampling equipment must be decontaminated between samples and at the end of each day. Drilling and excavation equipment should be decontaminated prior to beginning site activities, before collecting each sample when non-dedicated sampling equipment is used, and after completing site activities. Decontamination procedures are detailed in the following subsections.

2.1 Decontamination Area

A localized decontamination area should be identified for larger drilling and excavation equipment. The area should have easy access and level ground to minimize slip, trip, and fall hazards. The decontamination area should be large enough to temporarily store clean equipment and materials and stage drums of investigation-derived waste (IDW). When decontaminating larger drilling tooling, such as hollow-stem augers, line each area with a heavy-gauge plastic sheeting and include a collection system designed to capture potential decontamination wastes (water and residual soil). Containerize decontamination water and residual soil in approved containers, such as DOT-approved 55-gallon drums. Decontamination areas should be organized in a manner to minimize overspray and risk to the surrounding environment.

Smaller equipment (spoons, trowels, groundwater sampling pumps, etc.) may be decontaminated near the sampling locations. In this case, all required decontamination supplies must be mobilized to the sampling location. A 5-gallon bucket with a screw top lid or a plastic tub should be used to capture decontamination water, which should be transferred to larger containers, as necessary.

2.2 Sampling Equipment Decontamination

Improper decontamination can cause cross-contamination. To avoid cross-contamination, sampling equipment must be either disposed of after one use or decontaminated after each use. Disposable or dedicated sampling equipment should be used whenever possible. When non-dedicated, reusable equipment is used, it should be decontaminated in stages in a way that minimizes contaminant release to the environment. The following procedures should be used:

- 1) Remove as much bulk contamination as possible from equipment at the point of origin.
- 2) Wash equipment thoroughly with potable water containing a laboratory-grade detergent, such as Liquinox or Alconox. Use a bristle brush to remove any remaining residual contamination.
- 3) Rinse equipment thoroughly with potable water.
- 4) Rinse equipment thoroughly with distilled or deionized water. Note that some instruments can be damaged by deionized water, such as YSI 556 probes.
- 5) Air dry equipment in clean area free of dust or other fugitive contaminants. Alternatively, wet equipment may be dried with a clean, disposable paper towel to assist the drying process. All equipment should be dry before reuse.
- 6) Store clean and dry sampling equipment within a protective medium (plastic bag or carrying case).

2.3 Heavy Equipment Decontamination

Heavy equipment decontamination must be performed prior to transporting or walking equipment between contaminated areas. Decontamination will focus on minimizing the spread of contaminated media resulting from equipment movement or transport. This decontamination process will use dry methods (brooms, brushes, shovels, etc.) to remove large, easily dislodged deposits of soil and other contaminated media from equipment (tracks, buckets, etc.) prior to exiting the exclusion zone. The Field Lead may alter decontamination procedures based on dry decontamination effectiveness.

Final decontamination should be conducted when equipment is no longer needed onsite. A decontamination area should be established to collect decontamination materials, sludge, and water. Bulk contamination should be removed using shovels and brushes, and the equipment should be further cleaned using a pressure washer with a detergent wash, followed by a potable water rinse, where necessary.

2.4 Personnel and Personal Protective Equipment Decontamination

During environmental investigations and removal actions, boots and gloves are commonly the most contaminated types of personal protective equipment (PPE). Contaminated solids, such as mud, should be scraped and wiped from boots. Personnel decontamination involves removal of bulk contamination first. Any remaining contamination should be removed using soapy water and brushes. Once all debris is removed, rinse the boots with clean water. If boots are not laden with solid materials, a brush can be used to knock off or remove any residual solid materials. If the boots have contacted liquid-phase contaminants, it is important that the contaminants be removed using soapy water and a brush, followed by a clean water rinse. If the contaminants have adsorbed into the boots, the boots must be replaced. Gloves should be removed rolling the glove off from the top down to avoid contact with contaminated soil.

Following removal and cleaning of reusable PPE, field personnel should wash their hands or any exposed body parts that may have contacted the associated contamination.

3. INVESTIGATION DERIVED WASTE MANAGEMENT

Typical investigation derived wastes consist of soil cuttings, decontamination water, and solid wastes. These wastes should be handled in accordance with the following steps:

- 1) Soil cuttings should be containerized in open-top, DOT-approved, 55-gallon drums. Decontamination water should be collected in plastic troughs or tubs, DOT-approved 55-gallon drums, or DOT-approved 5-gallon buckets with screw top lids.
- 2) Solid wastes generated during decontamination activities should be containerized in contractor grade plastic bags.

- 3) All wastes must be treated or disposed of in accordance with applicable state and federal regulations, as specified in the Work Plan or Waste Management Plan.
- 4) Prior to transporting soil cuttings or decontamination water off-site, an ADEC Contaminated Media Transport and Treatment or Disposal Approval Form must be submitted to the ADEC Project Manager for approval (Attachment 1).

4. QUALITY CONTROL

Quality Control (QC) samples may be collected to verify that the decontamination procedures are effective. QC samples include equipment rinsate blanks and equipment wipe samples, which are described in SOP-14 Quality Control Samples.

ATTACHMENTS

Attachment 1: ADEC Contaminated Media Transport and Treatment or Disposal Approval Form

**Attachment 1: ADEC Contaminated Media Transport and Treatment or Disposal Approval
Form**

This page intentionally blank



ALASKA DEPARTMENT OF ENVIRONMENTAL CONSERVATION
DIVISION OF SPILL PREVENTION AND RESPONSE
 Contaminated Sites and Prevention and Emergency Response Programs
Transport, Treatment, & Disposal Approval Form for Contaminated Media

DEC HAZARD/SPILL ID #		NAME OF SPILL OR CONTAMINATED SITE	
SITE OR SPILL LOCATION			
CURRENT LOCATION AND TYPE OF CONTAMINATED MEDIA		SOURCE OF THE CONTAMINATION	
COMPOUNDS OF CONCERN	ESTIMATED VOLUME	DATE(S) GENERATED	
POST TREATMENT ANALYSIS REQUIRED <i>(such as GRO, DRO, RRO, BTEX, and/or Chlorinated Solvents)</i>			
COMMENTS			

Facility Accepting the Contaminated Media

NAME OF THE FACILITY	PHYSICAL ADDRESS/PHONE NUMBER

Responsible Party and Contractor Information

BUSINESS/NAME	ADDRESS/PHONE NUMBER

Name of the Person Requesting Approval (printed)

Title/Association

Signature

Date

Phone Number

-----DEC USE ONLY-----

Based on the information provided, ADEC approves transport of the above-described media for treatment in accordance with the approved facility operations plan. The Responsible Party or their consultant must submit to the DEC Project Manager a copy of weight/volume receipts of the loads transported to the facility and a post treatment analytical report. If the media is contaminated soil, it shall be transported as a covered load in compliance with 18 AAC 60.015.

DEC Project Manager Name (printed)

Project Manager Title

Signature

Date

Phone Number

This page intentionally blank

STANDARD OPERATING PROCEDURE

SOP-17

SAMPLE MANAGEMENT

This Standard Operating Procedure (SOP) will be used to direct field personnel in the techniques and requirements for sample management, including maintaining a chain-of-custody (COC); and labeling, packing, shipping environmental samples to the laboratory for analysis.

1.0 MATERIALS

Equipment required includes:

- Sample labels
- Laboratory receipt forms
- Field custody forms (COC form)
- Custody seals
- Inter-laboratory transfer documentation, if applicable
- Weatherproof labels for sample containers
- Coolers
- Gel ice packs
- Sorbent pads
- Contractor-grade plastic bags
- Bubble wrap and/or foam inserts
- Plastic zip-top bags, quart and gallon
- Clear tape
- Strapping tape
- Cooler labels: keep cool/refrigerate/do not freeze, this end up, fragile, dangerous goods in excepted quantities, shipping address, etc.

2.0 PROCEDURES

An environmental sample is any sample that has less than reportable quantities of any hazardous constituents according to Department of Transportation (DOT) 49 CFR - Section 172. This section

describes the procedures for maintaining COC; and labeling, packing, and shipping collected samples.

2.1 Sample Chain-of-Custody Procedures

The COC record accompanies all sample shipments. Two COC records are prepared for each shipment. One COC record is placed in a re-sealable plastic bag with the bag sealed shut to prevent water intrusion from moisture in the cooler, and the bag is taped inside the cooler lid. The duplicate or electronic copy of the COC record is retained by the sampler and provided to the Project Chemist and other sample coordinators. Airway bills are retained with the COC record and provided to the Project Chemist, so sample pickup can be coordinated with the laboratory. Airway bills must be scanned and stored in electronic format.

2.1.1 Sample Documentation

Sample identification documents are carefully prepared so that sample identification and COC are maintained. Sample identification documents include the field logbook, sample labels, custody seals, and COC records.

A sample is in custody if it meets one of the following conditions:

- Is in an authorized person's physical possession.
- Is in an authorized person's view after being in possession.
- Is in an authorized person's possession and then secured (locked up).
- Is kept in a secured area that is restricted to authorized personnel.

2.1.2 Field Custody

The following procedures should be adhered to in the field to ensure that custody is maintained:

- The sample collector is personally responsible for the care and custody of samples collected until they are properly transferred to another company representative or relinquished to the laboratory.
- The sample collector records sample data (time of collection, sample number, analytical requirements, and matrix) in the field logbook and/or on the appropriate field form.
- Sample labels are completed for each sample, using weatherproof ink.

2.1.3 Chain-of-Custody Record

The COC record is fully completed prior to sample shipment. When possible, an electronic COC record should be used. Required information on the COC includes the following:

- Client (contractor name)

- Reporting Information (Chemist name and contact information)
- Project Name
- Invoice information
- PO Number
- COC number
- Cooler ID
- Page number
- NPDL number (for USACE projects only)
- Field Sample ID
- Location ID
- Collection date
- Collection time (in 24-hour format)
- Sampler initials
- Quantity (number of containers)
- Container types (VOA, amber, 40 mL, etc.)
- Container volumes
- Preservative
- Sample matrix (soil, water, other)
- Requested laboratory analysis methods required for each jar
- Quality control (trip blanks and MS/MSD)
- Turn-around-time (TAT)
- Notes
- Special instructions

2.1.4 Custody Seals

Custody seals are preprinted, adhesive-backed seals with security slots designed to break if the seals are disturbed. Seals are signed and dated when applied to the cooler. Sample shipping containers (coolers) are sealed in as many places as necessary to ensure that the container cannot be opened without tearing the custody seals. Typically, one custody seal is placed along the front corner of the cooler, and a second is placed along the opposite back corner of the

cooler. Clear tape is placed over the seals to ensure that seals are not accidentally broken during shipment. If the custody seal was broken at some point during transport, the reason for breaking the seal, condition of the container contents, the cooler temperature, and anything added to or removed from the container must be documented on the COC form. The container must then be sealed with a new custody seal.

If a sample handler transports the samples directly to the laboratory without shipment, custody seals are not required.

2.1.5 Transfer of Custody

When transferring the possession of samples from the field sampler to a transporter or the laboratory, the sampler must sign, date, and note the time as “relinquished by” on the COC record. The receiver also signs, dates, and notes the time as “received by” on the COC record; however, when samples are transported by a common commercial carrier, such as Alaska Airlines or Federal Express, the carrier does not sign the COC record. Instead, the COC record is signed by the sampler as “relinquished by” prior to closing the sample coolers for shipment and relinquishing them to the commercial carrier.

2.1.6 Laboratory Custody

A designated sample custodian accepts custody of the shipped samples and verifies that the sample identifications match the COC record. The laboratory completes a cooler receipt form when samples are received. The cooler receipt form documents any discrepancies identified between the sample labels and COC, cooler temperature(s), sample preservation, and sample integrity. Cooler receipt information, including a signed COC, custody seals, and a completed cooler receipt form, are provided to the Project Chemist. If the project is for the USACE, these items must be emailed to receipt.cooler@usace.army.mil within 24 hours of cooler receipt.

2.2 Sample Labeling, Packing, and Shipping Procedures

Samples must be labeled using nomenclature defined in the project Work Plan. All sample labels must be weatherproof and contain the following information:

- Project or project number
- Sampler name or initials
- Sample identification
- Sample date and time (in 24-hour format)
- Laboratory analysis methods required for sample jar
- Preservatives added to sample jar

Adhesive sample labels are placed directly on the sample containers. If the labels do not adequately adhere due to moisture, secure the label by placing clear packing tape over the label. Sample containers that are weighed by the laboratory prior to use, such as those used for volatile soil sample collection, should not have any additional labels or tape placed on the container as it affects the weight. For those containers, use the label that is already provided on the jar. Only one label should be placed on each sample container.

2.2.1 Packing

When packing sample containers for shipment, the steps below must be followed.

1. Choose a cooler with structural integrity to withstand shipment. Secure and tape the drain plug with duct tape.
2. Be sure that container lids are tight and will not leak.
3. Ensure that the sample labels are intact, fully completed with the correct information, and that the sample identification exactly matches the COC record.
4. Place sample containers in bubble wrap, bubble bags, in their original boxes, or in re-sealable bags with sorbent pads, depending on the type of container. Wrap and package containers sufficiently to prevent cross contamination and ensure that containers remain intact during shipment (bubble wrap and plastic zip-top bags).
5. Place a layer of frozen gel ice packs, along the bottom of the cooler. Cover the ice packs with a layer of bubble wrap and then place a sorbent pad over the bubble wrap.
6. Line the cooler with a contractor-grade plastic bag.
7. Place the containers inside the contractor-grade plastic bag with caps up.
8. Ensure that a temperature blank is included in each cooler. The temperature blank should be placed at the same level and next to the samples, preferably in the center of the cooler.
9. If the cooler contains volatile samples, ensure that a trip blank is included.
10. Fill excess space between sample containers with additional bubble wrap or gel ice.
11. Tape the top of the contractor-grade plastic bag shut once all sample containers, trip blanks, and the temp blank are inside.
12. Place another layer of bubble wrap along the top of the cooler, and if possible, place a layer of gel ice packs along the top of the cooler. Use sufficient ice in packaging to ensure that samples are received by the laboratory at the proper temperature (0 to 6°C). Note that partially melted or soft gel ice packs should not be used to pack coolers for transport. A minimum of 8 frozen gel ice packs should be used to maintain sample temperature during transit for 24 hours.

13. Fill remaining headspace with additional packing material.
14. Place the completed COC record for the laboratory into a plastic zip-top bag, tape the bag to the inner side of the cooler lid, and then close the cooler.
15. Conduct a shake test by gently shaking the cooler to determine if the containers are shifting in the cooler. If so, add additional packing material until there are no sounds of shifting when shaken.
16. Wrap strapping tape around each end of the cooler two times to secure the lid. Place completed custody seals on the front and back of the cooler so that the cooler cannot be opened without breaking the seals. Place clear tape over custody seals.
17. Attach an address label containing the name and address of the shipper to the top of the cooler. Attach other markings such as “Refrigerate” or “Keep Cool,” “Do Not Freeze,” and “Fragile.” For samples with liquid (including preserved soil samples), place “up arrow” stickers on opposite sides of the cooler pointing in the same direction as the containers containing liquids. For samples containing dangerous goods in excepted quantities, place a “dangerous goods in excepted quantities” label with the hazard class number on the top of the cooler (see Section 2.2.2 for additional details).

2.2.2 Sample Shipping

Environmental samples are shipped as non-hazardous materials unless the samples meet the established DOT criteria for a “hazardous material” or the International Air Transport Association (IATA)/International Civil Aviation Organization (ICAO) air definition of “dangerous goods.” If the samples meet criteria for hazardous materials or dangerous goods, then DOT and IATA/ICAO regulations must be followed, which includes having qualified personnel make the shipments.

Samples shipped as “Dangerous Goods in Excepted Quantities” must have the appropriate labelling and be declared as dangerous goods to the shipping carrier; however, a dangerous goods “candy-striped” form and Notification to Caption (NOTOC) are not required (IATA 2020).

2.2.2.1 Soil Sample Shipments

Soil samples preserved with methanol, and any excess methanol vials, must be shipped as “Dangerous Goods in Excepted Quantities” per the IATA regulations. The volume for excepted quantities of methanol is 30 mL per container and 500 mL per cooler. The hazard class number is 3, flammable liquid. Sample jars with methanol in excess of 30 mL and coolers with methanol in excess of 500 mL require shipment as “Dangerous Goods in Limited Quantities” and require the completion of a “candy-striped” form.

2.2.2.2 Water Sample Shipments

Water samples preserved with hydrochloric acid or other insignificant amounts of preservative are not shipped as dangerous goods once filled; however, pre-preserved sample containers with preservative and no water added must be shipped as “Dangerous Goods in Excepted Quantities” per IATA regulations. The volume for excepted quantities of hydrochloric acid or nitric acid is 30 mL per container and 500 mL per cooler, respectively. The hazard class number is 8, corrosive. Sample jars with hydrochloric acid or nitric acid in excess of 30 mL and coolers with hydrochloric acid or nitric acid in excess of 500 mL require shipment as “Dangerous Goods” and require the completion of a “candy-striped” form.

Upon shipping samples, notify the laboratory contact that samples have been shipped and provide the airway bill number.

3.0 REFERENCES

Alaska Department of Environmental Conservation (ADEC). 2022. Field Sampling Guidance. January.

International Air Transport Association (IATA). 2020. Dangerous Goods Regulations Limited/Excepted Quantities Labels.

ATTACHMENTS

Attachment 1: Chain-of-Custody Form

This page intentionally blank

Attachment 1: Chain-of-Custody Form

This page intentionally blank

Chain-of-Custody Report

Collection Organization:	Chain-of-Custody:	Cooler ID:	NPDL Number:
Project Number:	Laboratory:	Bill To:	Report To:

COC Sample ID	Loc ID	Collection Date	Collection Time	Sampler	Quantity	Container Type	Volume	Preservative	Matrix	Analyses Requested	Group	QC	TAT	Notes:

Special Instructions:

Relinquish By:	Relinquish By:	Temperature Blank:
Signature/Printed Name	Signature/Printed Name	
Date/Time	Date/Time	
Received By:	Received By:	Cooler Temperature:
Signature/Printed Name	Signature/Printed Name	
Date/Time	Date/Time	

This page intentionally blank

STANDARD OPERATING PROCEDURE

SOP-18

LOGBOOK DOCUMENTATION AND FIELD NOTES

This Standard Operating Procedure (SOP) describes the content and format of field logbooks. It was generated in accordance with the Alaska Department of Environmental Conservation (ADEC) Field Sampling Guidance (ADEC 2022) and United States Army Corps of Engineers, Alaska District requirements. This SOP will be used to direct personnel in field documentation and record keeping requirements to ensure that field activities are properly documented.

Adequate documentation is necessary to describe the work performed. Attention to detail is vital as field logbooks are used in the reporting process as well as in administrative and judicial proceedings. As a result, it is important that documentation be factual, complete, accurate, consistent, and clear. All site personnel who make logbook entries are responsible for maintaining the required documentation. The Field Lead designates who will be responsible for field notebook and form entries.

1. FIELD LOGBOOK PROCEDURE

Field logbooks are bound, sequentially paginated, weatherproof notebooks used to record daily field activities and are permanently assigned to a specific project. All notes must be printed legibly in permanent ink.

1.1 Front Cover

The front cover of each logbook must include the following information:

- Owner of the book (Example: ARS Aleut Remediation)
- Book number
- Job name, Contract number, and/or Client
- Start date
- End date

1.2 Project Contact Information

Include project contact information on the inside front cover or first page of the logbook. Contact information may include names and phone numbers of subcontractors, project assistants, field team members, and emergency numbers from the Accident Prevention Plan and/or Site-Specific Health and Safety Plan.

1.3 Daily Entries

Logbook entries must abide by the following guidelines:

- Pages can never be removed from the logbook.
- All information is printed legibly in waterproof ink.
- Entries are written in chronological order using objective and factual language.
- Entries are written on subsequent lines such that no blank lines exist on any page.
- If any space remains on the bottom of the last page at the conclusion of the day's field entries, a diagonal line is drawn and signed to obscure any additional entries on that page.
- If corrections are necessary, a single line is drawn through the original entry. The corrected information is then added, initialed, and dated.

The minimum daily standard logbook entries include the following:

- Project name/Site ID/Client/Page Number
- Date and time
- Weather, site conditions, and other salient conditions
- Work start and stop times
- Full names, affiliations and project titles, and roles of personnel on site, including visitors
- Daily objectives
- Safety meetings/tailgates
- Time and location of activities
- Field observations and comments
- Level of personal protective equipment
- Photograph log (photograph name, frame number, description, date, and time)
- Name(s) of person(s) collecting samples or performing work
- Sketch of site location with north arrows when appropriate, sample and field screening locations, depths, and groundwater flow direction.
- Survey information (include latitude and longitude coordinates when possible)

- All field measurements (e.g., leak check results, geochemical parameters, field screening results).
- Sample record (sample identification, date, time, media, number of samples, and location)
- Sample shipping information (date, time, destination, location)
- Type of field instrumentation used (model and serial numbers)
- All daily equipment calibrations performed and maintenance
- Description of remediation activities performed (system performance, system calibration or maintenance record, excavation activities and volume of material removed).
- Other work performed and observations made
- Any deviations from the site-specific approved work plan
- Waste tracking information (when, media, how much, destination).

Correct erroneous field record or logbook entries with a single line through the error. Do not erase incorrect information. Date and initial revised entries.

2. FIELD DATA SHEETS

All other supportive unbound data documentation that is a part of the field records are maintained as part of the field forms. These entries are recorded in weatherproof ink on weatherproof paper and kept in a field file folder. It is not necessary to duplicated information recorded on a field form into the project logbook.

3. ELECTRONIC DATA SHEETS

Electronic data documents include photographs, GPS and survey data, etc. All electronic data that are part of the field records are downloaded to a designated location. Take care when downloading, storing, and managing data. Naming conventions (according to the Work Plan) are used to indicate the project, date, and other relevant information.

4. DOCUMENT CONTROL

At the conclusion of a task or project, all field documentation, including logbooks and field forms, is scanned and placed in a designated location (typically the “Field” folder). Electronic data and photographs collected during the field effort should also be saved to this location.

5. REFERENCES

Alaska Department of Environmental Conservation (ADEC). 2022. Field Sampling Guidance. January.

ATTACHMENT 4
LABORATORY CERTIFICATIONS

This page intentionally blank



THE STATE
of **ALASKA**
GOVERNOR MICHAEL J. DUNLEAVY

Department of Environmental Conservation

DIVISION OF SPILL PREVENTION AND RESPONSE
Contaminated Sites Program
Laboratory Approval Program

555 Cordova Street
Anchorage, Alaska 99501
Main: 907.465.5390
Fax: 907.269.7649
cs.lab.cert@alaska.gov

January 10, 2022

Charles Homestead
SGS North America Inc. - Anchorage
200 W. Potter Drive
Anchorage, AK 99518-1605

RE: Contaminated Sites Laboratory Approval **17-021**

Thank you for submitting a completed application to the Alaska Department of Environmental Conservation's Contaminated Sites Laboratory Approval Program (CS-LAP), on January 7, 2022. Based on your lab's Department of Defense Environmental Laboratory Accreditation Program (DoD-ELAP) approval through the American Association for Laboratory Accreditation (A2LA), SGS North America Inc. - Anchorage, located at the above address, is granted **Approved** status to perform the analyses listed in the attached *Scope of Approval*, for Alaska contaminated sites projects, including underground storage tanks and leaking underground storage tank sites (UST/LUST), under the July 1, 2017 amendments to 18 AAC 78. This approval is effective January 10, 2022 and expires on **January 31, 2024**.

Be aware that in accordance with 18 AAC 78.815(b) and 18 AAC 78.815(e), **any** changes in your lab's NELAP and/or DoD-ELAP approval status for **any** analytes in **any** methods or **any** matrices must be reported to the CS-LAP within 3 business days. This includes any suspension of any analyte(s) due to failed Performance Testing (PT) or Performance Evaluation (PE) samples.

FAILURE TO REPORT A CHANGE IN STATUS WILL RESULT IN REVOCATION OF ALL CS-LAP APPROVALS FOR ALL ANALYTES AND ALL METHODS IN ALL MATRICES FOR A PERIOD OF ONE YEAR.

Notification should be in writing sent to cs.lab.cert@alaska.gov. We recommend also contacting the CS-LAP by telephone to verify that the message was received.

If you have any questions, please contact the CS-LAP at (907) 465-5390, or by email at cs.lab.cert@alaska.gov. Labs are also highly encouraged to join the CS-LAP listserv by going to <http://list.state.ak.us/mailman/listinfo/cs.lab.approval>.

Respectfully,

Brian Engled

Attachment: Scope of Approval

Scope of Approval

CAS Number	Matrix	Hazardous Substance	Method	Accreditation Body
83-32-9	Soil	Acenaphthene	8270D	A2LA
83-32-9	Water	Acenaphthene	8270D	A2LA
83-32-9	Soil	Acenaphthene	8270D-SIM	A2LA
83-32-9	Water	Acenaphthene	8270D-SIM	A2LA
208-96-8	Soil	Acenaphthylene	8270D	A2LA
208-96-8	Water	Acenaphthylene	8270D	A2LA
208-96-8	Soil	Acenaphthylene	8270D-SIM	A2LA
208-96-8	Water	Acenaphthylene	8270D-SIM	A2LA
67-64-1	Soil	Acetone	8260D	A2LA
67-64-1	Water	Acetone	8260D	A2LA
309-00-2	Soil	Aldrin	8270D-SIM	A2LA
309-00-2	Water	Aldrin	8270D-SIM	A2LA
120-12-7	Soil	Anthracene	8270D	A2LA
120-12-7	Water	Anthracene	8270D	A2LA
120-12-7	Soil	Anthracene	8270D-SIM	A2LA
120-12-7	Water	Anthracene	8270D-SIM	A2LA
7440-36-0	Soil	Antimony (metallic)	6020B	A2LA
7440-36-0	Water	Antimony (metallic)	6020B	A2LA
7440-38-2	Soil	Arsenic, Inorganic	6020B	A2LA
7440-38-2	Water	Arsenic, Inorganic	6020B	A2LA
7440-39-3	Soil	Barium	6020B	A2LA
7440-39-3	Water	Barium	6020B	A2LA
56-55-3	Soil	Benz[a]anthracene	8270D	A2LA
56-55-3	Water	Benz[a]anthracene	8270D	A2LA
56-55-3	Soil	Benz[a]anthracene	8270D-SIM	A2LA
56-55-3	Water	Benz[a]anthracene	8270D-SIM	A2LA
71-43-2	Soil	Benzene	8260D	A2LA
71-43-2	Water	Benzene	8260D	A2LA
50-32-8	Soil	Benzo[a]pyrene	8270D	A2LA
50-32-8	Water	Benzo[a]pyrene	8270D	A2LA
205-99-2	Soil	Benzo[b]fluoranthene	8270D	A2LA
205-99-2	Water	Benzo[b]fluoranthene	8270D	A2LA
205-99-2	Soil	Benzo[b]fluoranthene	8270D-SIM	A2LA

Scope of Approval

CAS Number	Matrix	Hazardous Substance	Method	Accreditation Body
205-99-2	Water	Benzo[b]fluoranthene	8270D-SIM	A2LA
191-24-2	Soil	Benzo[g,h,i]perylene	8270D	A2LA
191-24-2	Water	Benzo[g,h,i]perylene	8270D	A2LA
191-24-2	Soil	Benzo[g,h,i]perylene	8270D-SIM	A2LA
191-24-2	Water	Benzo[g,h,i]perylene	8270D-SIM	A2LA
207-08-9	Soil	Benzo[k]fluoranthene	8270D	A2LA
207-08-9	Water	Benzo[k]fluoranthene	8270D	A2LA
207-08-9	Soil	Benzo[k]fluoranthene	8270D-SIM	A2LA
207-08-9	Water	Benzo[k]fluoranthene	8270D-SIM	A2LA
65-85-0	Soil	Benzoic Acid	8270D	A2LA
65-85-0	Water	Benzoic Acid	8270D	A2LA
100-51-6	Soil	Benzyl Alcohol	8270D	A2LA
100-51-6	Water	Benzyl Alcohol	8270D	A2LA
7440-41-7	Soil	Beryllium and compounds	6020B	A2LA
7440-41-7	Water	Beryllium and compounds	6020B	A2LA
111-44-4	Soil	Bis(2-chloroethyl)ether	8270D	A2LA
111-44-4	Water	Bis(2-chloroethyl)ether	8270D	A2LA
117-81-7	Soil	Bis(2-ethylhexyl)phthalate (DEHP)	8270D	A2LA
117-81-7	Water	Bis(2-ethylhexyl)phthalate (DEHP)	8270D	A2LA
108-86-1	Soil	Bromobenzene	8260D	A2LA
108-86-1	Water	Bromobenzene	8260D	A2LA
75-27-4	Soil	Bromodichloromethane	8260D	A2LA
75-27-4	Water	Bromodichloromethane	8260D	A2LA
75-25-2	Soil	Bromoform	8260D	A2LA
75-25-2	Water	Bromoform	8260D	A2LA
74-83-9	Soil	Bromomethane	8260D	A2LA
74-83-9	Water	Bromomethane	8260D	A2LA
85-68-7	Soil	Butyl Benzyl Phthalate	8270D	A2LA
85-68-7	Water	Butyl Benzyl Phthalate	8270D	A2LA
104-51-8	Soil	Butylbenzene, n-	8260D	A2LA
104-51-8	Water	Butylbenzene, n-	8260D	A2LA
135-98-8	Soil	Butylbenzene, sec-	8260D	A2LA
135-98-8	Water	Butylbenzene, sec-	8260D	A2LA

Scope of Approval

CAS Number	Matrix	Hazardous Substance	Method	Accreditation Body
98-06-6	Soil	Butylbenzene, tert-	8260D	A2LA
98-06-6	Water	Butylbenzene, tert-	8260D	A2LA
7440-43-9	Soil	Cadmium	6020B	A2LA
7440-43-9	Water	Cadmium	6020B	A2LA
75-15-0	Soil	Carbon Disulfide	8260D	A2LA
75-15-0	Water	Carbon Disulfide	8260D	A2LA
56-23-5	Soil	Carbon Tetrachloride	8260D	A2LA
56-23-5	Water	Carbon Tetrachloride	8260D	A2LA
5103-71-9	Soil	Chlordane, α -	8270D-SIM	A2LA
5103-71-9	Water	Chlordane, α -	8270D-SIM	A2LA
5103-74-2	Soil	Chlordane, γ -	8270D-SIM	A2LA
5103-74-2	Water	Chlordane, γ -	8270D-SIM	A2LA
12789-03-6	Soil	Chlordane, Total	8270D-SIM	A2LA
12789-03-6	Water	Chlordane, Total	8270D-SIM	A2LA
106-47-8	Soil	Chloroaniline, p-	8270D	A2LA
106-47-8	Water	Chloroaniline, p-	8270D	A2LA
108-90-7	Soil	Chlorobenzene	8260D	A2LA
108-90-7	Water	Chlorobenzene	8260D	A2LA
67-66-3	Soil	Chloroform	8260D	A2LA
67-66-3	Water	Chloroform	8260D	A2LA
74-87-3	Soil	Chloromethane	8260D	A2LA
74-87-3	Water	Chloromethane	8260D	A2LA
91-58-7	Soil	Chloronaphthalene, Beta-	8270D	A2LA
91-58-7	Water	Chloronaphthalene, Beta-	8270D	A2LA
7440-47-3	Soil	Chromium (Total)	6020B	A2LA
7440-47-3	Water	Chromium (Total)	6020B	A2LA
218-01-9	Soil	Chrysene	8270D	A2LA
218-01-9	Water	Chrysene	8270D	A2LA
7440-50-8	Soil	Copper	6020B	A2LA
7440-50-8	Water	Copper	6020B	A2LA
N/A	Soil	Cresol, m- (3-Methylphenol) + Cresol, p- (4-Methylphenol)	8270D	A2LA
N/A	Water	Cresol, m- (3-Methylphenol) + Cresol, p- (4-Methylphenol)	8270D	A2LA
95-48-7	Soil	Cresol, o- (2-Methylphenol)	8270D	A2LA

Scope of Approval

CAS Number	Matrix	Hazardous Substance	Method	Accreditation Body
95-48-7	Water	Cresol, o- (2-Methylphenol)	8270D	A2LA
72-54-8	Soil	DDD, 4,4'-	8270D-SIM	A2LA
72-54-8	Water	DDD, 4,4'-	8270D-SIM	A2LA
72-55-9	Soil	DDE, 4,4'-	8270D-SIM	A2LA
72-55-9	Water	DDE, 4,4'-	8270D-SIM	A2LA
50-29-3	Soil	DDT, 4,4'-	8270D-SIM	A2LA
50-29-3	Water	DDT, 4,4'-	8270D-SIM	A2LA
53-70-3	Soil	Dibenz[a,h]anthracene	8270D	A2LA
53-70-3	Water	Dibenz[a,h]anthracene	8270D	A2LA
132-64-9	Soil	Dibenzofuran	8270D	A2LA
132-64-9	Water	Dibenzofuran	8270D	A2LA
124-48-1	Soil	Dibromochloromethane	8260D	A2LA
124-48-1	Water	Dibromochloromethane	8260D	A2LA
106-93-4	Soil	Dibromoethane, 1,2- (Ethylene Dibromide)	8260D	A2LA
106-93-4	Water	Dibromoethane, 1,2- (Ethylene Dibromide)	8260D	A2LA
106-93-4	Soil	Dibromoethane, 1,2- (Ethylene Dibromide)	8260D-SIM	A2LA
106-93-4	Water	Dibromoethane, 1,2- (Ethylene Dibromide)	8260D-SIM	A2LA
74-95-3	Soil	Dibromomethane (Methylene Bromide)	8260D	A2LA
74-95-3	Water	Dibromomethane (Methylene Bromide)	8260D	A2LA
84-74-2	Soil	Dibutyl Phthalate	8270D	A2LA
84-74-2	Water	Dibutyl Phthalate	8270D	A2LA
95-50-1	Soil	Dichlorobenzene, 1,2-	8260D	A2LA
95-50-1	Water	Dichlorobenzene, 1,2-	8260D	A2LA
95-50-1	Soil	Dichlorobenzene, 1,2-	8270D	A2LA
95-50-1	Water	Dichlorobenzene, 1,2-	8270D	A2LA
541-73-1	Soil	Dichlorobenzene, 1,3-	8260D	A2LA
541-73-1	Water	Dichlorobenzene, 1,3-	8260D	A2LA
541-73-1	Soil	Dichlorobenzene, 1,3-	8270D	A2LA
541-73-1	Water	Dichlorobenzene, 1,3-	8270D	A2LA
106-46-7	Soil	Dichlorobenzene, 1,4-	8260D	A2LA
106-46-7	Water	Dichlorobenzene, 1,4-	8260D	A2LA
106-46-7	Soil	Dichlorobenzene, 1,4-	8270D	A2LA
106-46-7	Water	Dichlorobenzene, 1,4-	8270D	A2LA

Scope of Approval

CAS Number	Matrix	Hazardous Substance	Method	Accreditation Body
91-94-1	Soil	Dichlorobenzidine, 3,3'-	8270D	A2LA
91-94-1	Water	Dichlorobenzidine, 3,3'-	8270D	A2LA
75-71-8	Soil	Dichlorodifluoromethane (Freon-12)	8260D	A2LA
75-71-8	Water	Dichlorodifluoromethane (Freon-12)	8260D	A2LA
75-34-3	Soil	Dichloroethane, 1,1-	8260D	A2LA
75-34-3	Water	Dichloroethane, 1,1-	8260D	A2LA
107-06-2	Soil	Dichloroethane, 1,2-	8260D	A2LA
107-06-2	Water	Dichloroethane, 1,2-	8260D	A2LA
75-35-4	Soil	Dichloroethylene, 1,1-	8260D	A2LA
75-35-4	Water	Dichloroethylene, 1,1-	8260D	A2LA
156-59-2	Soil	Dichloroethylene, 1,2-cis-	8260D	A2LA
156-59-2	Water	Dichloroethylene, 1,2-cis-	8260D	A2LA
156-60-5	Soil	Dichloroethylene, 1,2-trans-	8260D	A2LA
156-60-5	Water	Dichloroethylene, 1,2-trans-	8260D	A2LA
120-83-2	Soil	Dichlorophenol, 2,4-	8270D	A2LA
120-83-2	Water	Dichlorophenol, 2,4-	8270D	A2LA
78-87-5	Soil	Dichloropropane, 1,2-	8260D	A2LA
78-87-5	Water	Dichloropropane, 1,2-	8260D	A2LA
10061-01-5	Soil	Dichloropropene, cis-1,3-	8260D	A2LA
10061-01-5	Water	Dichloropropene, cis-1,3-	8260D	A2LA
10061-02-6	Soil	Dichloropropene, trans-1,3-	8260D	A2LA
10061-02-6	Water	Dichloropropene, trans-1,3-	8260D	A2LA
60-57-1	Soil	Dieldrin	8270D-SIM	A2LA
60-57-1	Water	Dieldrin	8270D-SIM	A2LA
N/A	Soil	Diesel Range Organics (C10 – C25)	AK 102	A2LA
N/A	Water	Diesel Range Organics (C10 – C25)	AK 102	A2LA
84-66-2	Soil	Diethyl Phthalate	8270D	A2LA
84-66-2	Water	Diethyl Phthalate	8270D	A2LA
105-67-9	Soil	Dimethylphenol, 2,4-	8270D	A2LA
105-67-9	Water	Dimethylphenol, 2,4-	8270D	A2LA
131-11-3	Soil	Dimethylphthalate	8270D	A2LA
131-11-3	Water	Dimethylphthalate	8270D	A2LA
51-28-5	Soil	Dinitrophenol, 2,4-	8270D	A2LA

Scope of Approval

CAS Number	Matrix	Hazardous Substance	Method	Accreditation Body
51-28-5	Water	Dinitrophenol, 2,4-	8270D	A2LA
121-14-2	Soil	Dinitrotoluene, 2,4- (2,4-DNT)	8270D	A2LA
121-14-2	Water	Dinitrotoluene, 2,4- (2,4-DNT)	8270D	A2LA
606-20-2	Soil	Dinitrotoluene, 2,6- (2,6-DNT)	8270D	A2LA
606-20-2	Water	Dinitrotoluene, 2,6- (2,6-DNT)	8270D	A2LA
123-91-1	Soil	Dioxane, 1,4-	8260D-SIM	A2LA
123-91-1	Water	Dioxane, 1,4-	8260D-SIM	A2LA
959-98-8	Soil	Endosulfan I	8270D-SIM	A2LA
959-98-8	Water	Endosulfan I	8270D-SIM	A2LA
33213-65-9	Soil	Endosulfan II	8270D-SIM	A2LA
33213-65-9	Water	Endosulfan II	8270D-SIM	A2LA
1031-07-8	Soil	Endosulfan sulfate	8270D-SIM	A2LA
1031-07-8	Water	Endosulfan sulfate	8270D-SIM	A2LA
72-20-8	Soil	Endrin	8270D-SIM	A2LA
72-20-8	Water	Endrin	8270D-SIM	A2LA
75-00-3	Soil	Ethyl Chloride	8260D	A2LA
75-00-3	Water	Ethyl Chloride	8260D	A2LA
100-41-4	Soil	Ethylbenzene	8260D	A2LA
100-41-4	Water	Ethylbenzene	8260D	A2LA
206-44-0	Soil	Fluoranthene	8270D	A2LA
206-44-0	Water	Fluoranthene	8270D	A2LA
86-73-7	Soil	Fluorene	8270D	A2LA
86-73-7	Water	Fluorene	8270D	A2LA
N/A	Soil	Gasoline Range Organics (C6 – C10)	AK 101	A2LA
N/A	Water	Gasoline Range Organics (C6 – C10)	AK 101	A2LA
76-44-8	Soil	Heptachlor	8270D-SIM	A2LA
76-44-8	Water	Heptachlor	8270D-SIM	A2LA
1024-57-3	Soil	Heptachlor Epoxide	8270D-SIM	A2LA
1024-57-3	Water	Heptachlor Epoxide	8270D-SIM	A2LA
118-74-1	Soil	Hexachlorobenzene	8270D	A2LA
118-74-1	Water	Hexachlorobenzene	8270D	A2LA
87-68-3	Soil	Hexachlorobutadiene	8260D	A2LA
87-68-3	Water	Hexachlorobutadiene	8260D	A2LA

Scope of Approval

CAS Number	Matrix	Hazardous Substance	Method	Accreditation Body
87-68-3	Soil	Hexachlorobutadiene	8270D	A2LA
87-68-3	Water	Hexachlorobutadiene	8270D	A2LA
77-47-4	Soil	Hexachlorocyclopentadiene	8270D	A2LA
77-47-4	Water	Hexachlorocyclopentadiene	8270D	A2LA
67-72-1	Soil	Hexachloroethane	8270D	A2LA
67-72-1	Water	Hexachloroethane	8270D	A2LA
591-78-6	Soil	Hexanone, 2-	8260D	A2LA
591-78-6	Water	Hexanone, 2-	8260D	A2LA
193-39-5	Soil	Indeno[1,2,3-cd]pyrene	8270D	A2LA
193-39-5	Water	Indeno[1,2,3-cd]pyrene	8270D	A2LA
78-59-1	Soil	Isophorone	8270D	A2LA
78-59-1	Water	Isophorone	8270D	A2LA
7439-92-1	Soil	Lead, Total	6020B	A2LA
7439-92-1	Water	Lead, Total	6020B	A2LA
7439-96-5	Soil	Manganese	6020B	A2LA
7439-96-5	Water	Manganese	6020B	A2LA
7439-97-6	Soil	Mercury (elemental)	6020B	A2LA
7439-97-6	Water	Mercury (elemental)	6020B	A2LA
72-43-5	Soil	Methoxychlor	8270D-SIM	A2LA
72-43-5	Water	Methoxychlor	8270D-SIM	A2LA
78-93-3	Soil	Methyl Ethyl Ketone (2-Butanone)	8260D	A2LA
78-93-3	Water	Methyl Ethyl Ketone (2-Butanone)	8260D	A2LA
108-10-1	Soil	Methyl Isobutyl Ketone (4-methyl-2-pentanone)	8260D	A2LA
108-10-1	Water	Methyl Isobutyl Ketone (4-methyl-2-pentanone)	8260D	A2LA
1634-04-4	Soil	Methyl tert-Butyl Ether (MTBE)	8260D	A2LA
1634-04-4	Water	Methyl tert-Butyl Ether (MTBE)	8260D	A2LA
75-09-2	Soil	Methylene Chloride	8260D	A2LA
75-09-2	Water	Methylene Chloride	8260D	A2LA
90-12-0	Soil	Methylnaphthalene, 1-	8270D	A2LA
90-12-0	Water	Methylnaphthalene, 1-	8270D	A2LA
90-12-0	Soil	Methylnaphthalene, 1-	8270D-SIM	A2LA
90-12-0	Water	Methylnaphthalene, 1-	8270D-SIM	A2LA
91-57-6	Soil	Methylnaphthalene, 2-	8270D	A2LA

Scope of Approval

CAS Number	Matrix	Hazardous Substance	Method	Accreditation Body
91-57-6	Water	Methylnaphthalene, 2-	8270D	A2LA
91-57-6	Soil	Methylnaphthalene, 2-	8270D-SIM	A2LA
91-57-6	Water	Methylnaphthalene, 2-	8270D-SIM	A2LA
91-20-3	Soil	Naphthalene	8260D	A2LA
91-20-3	Water	Naphthalene	8260D	A2LA
91-20-3	Soil	Naphthalene	8270D	A2LA
91-20-3	Water	Naphthalene	8270D	A2LA
91-20-3	Soil	Naphthalene	8270D-SIM	A2LA
91-20-3	Water	Naphthalene	8270D-SIM	A2LA
7440-02-0	Soil	Nickel, Total	6020B	A2LA
7440-02-0	Water	Nickel, Total	6020B	A2LA
98-95-3	Soil	Nitrobenzene	8270D	A2LA
98-95-3	Water	Nitrobenzene	8270D	A2LA
62-75-9	Soil	Nitrosodimethylamine, N-	8270D	A2LA
62-75-9	Water	Nitrosodimethylamine, N-	8270D	A2LA
621-64-7	Soil	Nitroso-di-N-propylamine, N-	8270D	A2LA
621-64-7	Water	Nitroso-di-N-propylamine, N-	8270D	A2LA
86-30-6	Soil	Nitrosodiphenylamine, N-	8270D	A2LA
86-30-6	Water	Nitrosodiphenylamine, N-	8270D	A2LA
12674-11-2	Soil	PCB - Aroclor-1016	8082A	A2LA
12674-11-2	Water	PCB - Aroclor-1016	8082A	A2LA
11104-28-2	Soil	PCB - Aroclor-1221	8082A	A2LA
11104-28-2	Water	PCB - Aroclor-1221	8082A	A2LA
11141-16-5	Soil	PCB - Aroclor-1232	8082A	A2LA
11141-16-5	Water	PCB - Aroclor-1232	8082A	A2LA
53469-21-9	Soil	PCB - Aroclor-1242	8082A	A2LA
53469-21-9	Water	PCB - Aroclor-1242	8082A	A2LA
12672-29-6	Soil	PCB - Aroclor-1248	8082A	A2LA
12672-29-6	Water	PCB - Aroclor-1248	8082A	A2LA
11097-69-1	Soil	PCB - Aroclor-1254	8082A	A2LA
11097-69-1	Water	PCB - Aroclor-1254	8082A	A2LA
11096-82-5	Soil	PCB - Aroclor-1260	8082A	A2LA
11096-82-5	Water	PCB - Aroclor-1260	8082A	A2LA

Scope of Approval

CAS Number	Matrix	Hazardous Substance	Method	Accreditation Body
N/A	Soil	PCB – Total	8082A	A2LA
N/A	Water	PCB – Total	8082A	A2LA
87-86-5	Soil	Pentachlorophenol	8270D	A2LA
87-86-5	Water	Pentachlorophenol	8270D	A2LA
85-01-8	Soil	Phenanthrene	8270D	A2LA
85-01-8	Water	Phenanthrene	8270D	A2LA
85-01-8	Soil	Phenanthrene	8270D-SIM	A2LA
85-01-8	Water	Phenanthrene	8270D-SIM	A2LA
108-95-2	Soil	Phenol	8270D	A2LA
108-95-2	Water	Phenol	8270D	A2LA
103-65-1	Soil	Propyl benzene	8260D	A2LA
103-65-1	Water	Propyl benzene	8260D	A2LA
129-00-0	Soil	Pyrene	8270D	A2LA
129-00-0	Water	Pyrene	8270D	A2LA
129-00-0	Soil	Pyrene	8270D-SIM	A2LA
129-00-0	Water	Pyrene	8270D-SIM	A2LA
N/A	Soil	Residual Range Organics (C25 – C36)	AK 103	A2LA
N/A	Water	Residual Range Organics (C25 – C36)	AK 103	A2LA
7782-49-2	Soil	Selenium	6020B	A2LA
7782-49-2	Water	Selenium	6020B	A2LA
7440-22-4	Soil	Silver	6020B	A2LA
7440-22-4	Water	Silver	6020B	A2LA
7440-24-6	Soil	Strontium	6020B	A2LA
7440-24-6	Water	Strontium	6020B	A2LA
100-42-5	Soil	Styrene	8260D	A2LA
100-42-5	Water	Styrene	8260D	A2LA
630-20-6	Soil	Tetrachloroethane, 1,1,1,2-	8260D	A2LA
630-20-6	Water	Tetrachloroethane, 1,1,1,2-	8260D	A2LA
79-34-5	Soil	Tetrachloroethane, 1,1,2,2-	8260D	A2LA
79-34-5	Water	Tetrachloroethane, 1,1,2,2-	8260D	A2LA
127-18-4	Soil	Tetrachloroethylene	8260D	A2LA
127-18-4	Water	Tetrachloroethylene	8260D	A2LA
7440-28-0	Soil	Thallium, Total	6020B	A2LA

Scope of Approval

CAS Number	Matrix	Hazardous Substance	Method	Accreditation Body
7440-28-0	Water	Thallium, Total	6020B	A2LA
108-88-3	Soil	Toluene	8260D	A2LA
108-88-3	Water	Toluene	8260D	A2LA
8001-35-2	Soil	Toxaphene	8270D-SIM	A2LA
8001-35-2	Water	Toxaphene	8270D-SIM	A2LA
76-13-1	Soil	Trichloro-1,2,2-trifluoroethane, 1,1,2- (Freon 113)	8260D	A2LA
76-13-1	Water	Trichloro-1,2,2-trifluoroethane, 1,1,2- (Freon 113)	8260D	A2LA
87-61-6	Soil	Trichlorobenzene, 1,2,3-	8260D	A2LA
87-61-6	Water	Trichlorobenzene, 1,2,3-	8260D	A2LA
120-82-1	Soil	Trichlorobenzene, 1,2,4-	8260D	A2LA
120-82-1	Water	Trichlorobenzene, 1,2,4-	8260D	A2LA
120-82-1	Soil	Trichlorobenzene, 1,2,4-	8270D	A2LA
120-82-1	Water	Trichlorobenzene, 1,2,4-	8270D	A2LA
71-55-6	Soil	Trichloroethane, 1,1,1-	8260D	A2LA
71-55-6	Water	Trichloroethane, 1,1,1-	8260D	A2LA
79-00-5	Soil	Trichloroethane, 1,1,2-	8260D	A2LA
79-00-5	Water	Trichloroethane, 1,1,2-	8260D	A2LA
79-01-6	Soil	Trichloroethylene	8260D	A2LA
79-01-6	Water	Trichloroethylene	8260D	A2LA
75-69-4	Soil	Trichlorofluoromethane	8260D	A2LA
75-69-4	Water	Trichlorofluoromethane	8260D	A2LA
95-95-4	Soil	Trichlorophenol, 2,4,5-	8270D	A2LA
95-95-4	Water	Trichlorophenol, 2,4,5-	8270D	A2LA
88-06-2	Soil	Trichlorophenol, 2,4,6-	8270D	A2LA
88-06-2	Water	Trichlorophenol, 2,4,6-	8270D	A2LA
96-18-4	Soil	Trichloropropane, 1,2,3-	8260D	A2LA
96-18-4	Water	Trichloropropane, 1,2,3-	8260D	A2LA
96-18-4	Soil	Trichloropropane, 1,2,3-	8260D-SIM	A2LA
96-18-4	Water	Trichloropropane, 1,2,3-	8260D-SIM	A2LA
95-63-6	Soil	Trimethylbenzene, 1,2,4-	8260D	A2LA
95-63-6	Water	Trimethylbenzene, 1,2,4-	8260D	A2LA
108-67-8	Soil	Trimethylbenzene, 1,3,5-	8260D	A2LA
108-67-8	Water	Trimethylbenzene, 1,3,5-	8260D	A2LA

Scope of Approval

CAS Number	Matrix	Hazardous Substance	Method	Accreditation Body
7440-62-2	Soil	Vanadium, Total	6020B	A2LA
7440-62-2	Water	Vanadium, Total	6020B	A2LA
108-05-4	Soil	Vinyl Acetate	8260D	A2LA
108-05-4	Water	Vinyl Acetate	8260D	A2LA
75-01-4	Soil	Vinyl Chloride	8260D	A2LA
75-01-4	Water	Vinyl Chloride	8260D	A2LA
179601-23-1	Soil	Xylene, m+p-	8260D	A2LA
179601-23-1	Water	Xylene, m+p-	8260D	A2LA
95-47-6	Soil	Xylene, o-	8260D	A2LA
95-47-6	Water	Xylene, o-	8260D	A2LA
1330-20-7	Soil	Xylene, Total	8260D	A2LA
1330-20-7	Water	Xylene, Total	8260D	A2LA
7440-66-6	Soil	Zinc, Total	6020B	A2LA
7440-66-6	Water	Zinc, Total	6020B	A2LA



SCOPE OF ACCREDITATION TO ISO/IEC 17025:2017

SGS NORTH AMERICA INC. – ALASKA DIVISION
 200 W Potter Dr.
 Anchorage, AK 99518
 Mary McDonald Phone: (907)-550-3203
 mary.mcdonald@sgs.com

ENVIRONMENTAL

Valid To: December 31, 2023

Certificate Number: 2944.01

In recognition of the successful completion of the A2LA evaluation process, (including an assessment of the laboratory's compliance with ISO/IEC 17025:2017, the 2009 TNI Environmental Testing Laboratory Standard, and the requirements of the DoD Environmental Laboratory Accreditation Program (DoD ELAP) as detailed in version 5.4 of the DoD/DOE Quality Systems Manual for Environmental Laboratories) accreditation is granted to this laboratory to perform recognized EPA methods using the following testing technologies and in the analyte categories identified below:

Testing Technologies

Inductively Coupled Plasma Mass Spectroscopy, Gas Chromatography, Gas Chromatography/Mass Spectrometry, Ion Chromatography, Hazardous Waste Characteristics Tests, Total Organic Carbon

<u>Parameter/Analyte</u>	<u>Solid & Chemical Materials</u>	
	<u>Aqueous</u>	<u>Solid</u>
<u>Metals</u>		
Aluminum	EPA 6020B	EPA 6020B
Antimony	EPA 6020B	EPA 6020B
Arsenic	EPA 6020B	EPA 6020B
Barium	EPA 6020B	EPA 6020B
Beryllium	EPA 6020B	EPA 6020B
Boron	EPA 6020B	EPA 6020B
Cadmium	EPA 6020B	EPA 6020B
Calcium	EPA 6020B	EPA 6020B
Chromium	EPA 6020B	EPA 6020B
Cobalt	EPA 6020B	EPA 6020B
Copper	EPA 6020B	EPA 6020B
Iron	EPA 6020B	EPA 6020B
Lead	EPA 6020B	EPA 6020B
Magnesium	EPA 6020B	EPA 6020B
Manganese	EPA 6020B	EPA 6020B
Mercury	EPA 6020B EPA 7470A	EPA 6020B EPA 7471A
Molybdenum	EPA 6020B	EPA 6020B

<u>Parameter/Analyte</u>	<u>Solid & Chemical Materials</u>	
	<u>Aqueous</u>	<u>Solid</u>
Nickel	EPA 6020B	EPA 6020B
Potassium	EPA 6020B	EPA 6020B
Selenium	EPA 6020B	EPA 6020B
Silver	EPA 6020B	EPA 6020B
Sodium	EPA 6020B	EPA 6020B
Strontium	EPA 6020B	EPA 6020B
Thallium	EPA 6020B	EPA 6020B
Vanadium	EPA 6020B	EPA 6020B
Zinc	EPA 6020B	EPA 6020B
Metals Digestion Methods	EPA 3010A	EPA 3050B
Toxicity Characteristic Leaching Procedure	EPA 1311	EPA 1311
<u>Nutrients</u>		
Nitrate (as N)	EPA 9056A	EPA 9056A
Nitrate + Nitrite (as N)	EPA 9056A	EPA 9056A
Nitrite (as N)	EPA 9056A	EPA 9056A
<u>Demands</u>		
Total Organic Carbon	EPA 9060A	EPA 9060A
<u>Wet Chemistry</u>		
Bromide	EPA 9056A	EPA 9056A
Chloride	EPA 9056A	EPA 9056A
Fluoride	EPA 9056A	EPA 9056A
Sulfate	EPA 9056A	EPA 9056A
<u>Purgeable Organics (Volatiles)</u>		
Acetone	EPA 8260D	EPA 8260D
Benzene	EPA 8260D EPA 8021B	EPA 8260D EPA 8021B
Bromobenzene	EPA 8260D	EPA 8260D
Bromochloromethane	EPA 8260D	EPA 8260D
Bromodichloromethane	EPA 8260D	EPA 8260D
Bromoform	EPA 8260D	EPA 8260D
Bromomethane	EPA 8260D	EPA 8260D
2-Butanone	EPA 8260D	EPA 8260D
n-Butylbenzene	EPA 8260D	EPA 8260D
sec-Butylbenzene	EPA 8260D	EPA 8260D
tert-Butylbenzene	EPA 8260D	EPA 8260D
Carbon Disulfide	EPA 8260D	EPA 8260D
Carbon Tetrachloride	EPA 8260D	EPA 8260D
Chlorobenzene	EPA 8260D	EPA 8260D
Chloroethane	EPA 8260D	EPA 8260D
Chloroform	EPA 8260D	EPA 8260D
Chloromethane	EPA 8260D	EPA 8260D

<u>Parameter/Analyte</u>	<u>Solid & Chemical Materials</u>	
	<u>Aqueous</u>	<u>Solid</u>
2-Chlorotoluene	EPA 8260D	EPA 8260D
4-Chlorotoluene	EPA 8260D	EPA 8260D
Dibromochloromethane	EPA 8260D	EPA 8260D
1,2-Dibromo-3-chloropropane (DBCP)	EPA 8260D EPA 8260D SIM	EPA 8260D EPA 8260D SIM
Dibromomethane	EPA 8260D	EPA 8260D
1,2-Dibromoethane (EDB)	EPA 8260D EPA 8260D SIM	EPA 8260D EPA 8260D SIM
1,2-Dichlorobenzene	EPA 8260D	EPA 8260D
1,3-Dichlorobenzene	EPA 8260D	EPA 8260D
1,4-Dichlorobenzene	EPA 8260D	EPA 8260D
Dichlorodifluoromethane	EPA 8260D	EPA 8260D
1,1-Dichloroethane	EPA 8260D	EPA 8260D
1,2-Dichloroethane	EPA 8260D	EPA 8260D
1,1-Dichloroethene	EPA 8260D	EPA 8260D
cis-1,2-Dichloroethene	EPA 8260D	EPA 8260D
trans-1,2-Dichloroethene	EPA 8260D	EPA 8260D
1,2-Dichloropropane	EPA 8260D	EPA 8260D
1,3-Dichloropropane	EPA 8260D	EPA 8260D
2,2-Dichloropropane	EPA 8260D	EPA 8260D
1,1-Dichloropropene	EPA 8260D	EPA 8260D
cis-1,3-Dichloropropene	EPA 8260D	EPA 8260D
trans-1,3-Dichloropropene	EPA 8260D	EPA 8260D
1,4-Dioxane	EPA 8260D SIM	EPA 8260D SIM
Ethyl Benzene	EPA 8260D EPA 8021B	EPA 8260D EPA 8021B
Freon 113	EPA 8260D	EPA 8260D
2-Hexanone	EPA 8260D	EPA 8260D
Hexachlorobutadiene	EPA 8260D	EPA 8260D
Isopropylbenzene	EPA 8260D	EPA 8260D
4-Isopropyltoluene	EPA 8260D	EPA 8260D
Methylene chloride	EPA 8260D	EPA 8260D
4-Methyl-2-pentanone	EPA 8260D	EPA 8260D
Methyl tert-butyl ether	EPA 8260D	EPA 8260D
Naphthalene	EPA 8260D	EPA 8260D
n-Propylbenzene	EPA 8260D	EPA 8260D
Styrene	EPA 8260D	EPA 8260D
1,1,1,2-Tetrachloroethane	EPA 8260D	EPA 8260D
1,1,2,2-Tetrachloroethane	EPA 8260D	EPA 8260D
Tetrachloroethene	EPA 8260D	EPA 8260D
Toluene	EPA 8260D EPA 8021B	EPA 8260D EPA 8021B
1,2,3-Trichlorobenzene	EPA 8260D	EPA 8260D
1,2,4-Trichlorobenzene	EPA 8260D	EPA 8260D
1,1,1-Trichloroethane	EPA 8260D	EPA 8260D
1,1,2-Trichloroethane	EPA 8260D	EPA 8260D

<u>Parameter/Analyte</u>	<u>Solid & Chemical Materials</u>	
	<u>Aqueous</u>	<u>Solid</u>
Trichloroethene	EPA 8260D	EPA 8260D
Trichlorofluoromethane	EPA 8260D	EPA 8260D
1,2,3-Trichloropropane	EPA 8260D EPA 8260D SIM	EPA 8260D EPA 8260D SIM
1,2,4-Trimethylbenzene	EPA 8260D	EPA 8260D
1,3,5-Trimethylbenzene	EPA 8260D	EPA 8260D
Vinyl Acetate	EPA 8260D	EPA 8260D
Vinyl Chloride	EPA 8260D	EPA 8260D
Xylenes, Total	EPA 8260D EPA 8021B	EPA 8260D EPA 8021B
1,2-Xylene (O-Xylene)	EPA 8260D EPA 8021B	EPA 8260D EPA 8021B
1,3-Xylene & 1,4-Xylene (M+P-Xylene)	EPA 8260D EPA 8021B	EPA 8260D EPA 8021B
Toxicity Characteristic Leaching Procedure (ZHE)	EPA 1311	EPA 1311
Volatiles Preparation Methods	EPA 5030B	EPA 5035A
<u>Total Petroleum Hydrocarbons (TPH)</u>		
Gasoline Range Organics	EPA 8015C AK 101 (AK State Method)	EPA 8015C AK 101 (AK State Method)
GRO Preparation Methods	EPA 5030B	EPA 5035A
Diesel Range Organics	EPA 8015C AK 102 (AK State Method)	EPA 8015C AK 102 (AK State Method)
Residual Range Organics	EPA 8015C AK 103 (AK State Method)	EPA 8015C AK 103 (AK State Method)
DRO/RRO Preparation Methods	EPA 3520C Modified EPA 3630C	EPA 3550C, EPA 3630C
<u>Extractable Organics (Semi-volatiles)</u>		
Acenaphthene	EPA 8270D EPA 8270D SIM	EPA 8270D EPA 8270D SIM
Acenaphthylene	EPA 8270D EPA 8270D SIM	EPA 8270D EPA 8270D SIM
Aniline	EPA 8270D	EPA 8270D
Anthracene	EPA 8270D EPA 8270D SIM	EPA 8270D EPA 8270D SIM
Azobenzene	EPA 8270D	EPA 8270D
Benzoic Acid	EPA 8270D	EPA 8270D
Benzo(a)anthracene	EPA 8270D EPA 8270D SIM	EPA 8270D EPA 8270D SIM
Benzo(b)fluoranthene	EPA 8270D EPA 8270D SIM	EPA 8270D EPA 8270D SIM
Benzo(k)fluoranthene	EPA 8270D EPA 8270D SIM	EPA 8270D EPA 8270D SIM
Benzo(ghi)perylene	EPA 8270D EPA 8270D SIM	EPA 8270D EPA 8270D SIM

<u>Parameter/Analyte</u>	<u>Solid & Chemical Materials</u>	
	<u>Aqueous</u>	<u>Solid</u>
Benzo(a)pyrene	EPA 8270D EPA 8270D SIM	EPA 8270D EPA 8270D SIM
Benzyl Alcohol	EPA 8270D	EPA 8270D
Bis (2-chloroethoxy) Methane	EPA 8270D	EPA 8270D
Bis (2-chloroethyl) Ether	EPA 8270D	EPA 8270D
Bis (2-chloroisopropyl) Ether	EPA 8270D	EPA 8270D
Bis (2-ethylhexyl) Phthalate	EPA 8270D	EPA 8270D
4-bromophenylphenyl Ether	EPA 8270D	EPA 8270D
Butyl Benzyl Phthalate	EPA 8270D	EPA 8270D
Carbazole	EPA 8270D	EPA 8270D
4-Chloroaniline	EPA 8270D	EPA 8270D
4-Chloro-3-methylphenol	EPA 8270D	EPA 8270D
1-Chloronaphthalene	EPA 8270D	EPA 8270D
2-Chloronaphthalene	EPA 8270D	EPA 8270D
2-Chlorophenol	EPA 8270D	EPA 8270D
4-Chlorophenyl Phenyl Ether	EPA 8270D	EPA 8270D
Chrysene	EPA 8270D EPA 8270D SIM	EPA 8270D EPA 8270D SIM
Dibenzo(a,h)anthracene	EPA 8270D EPA 8270D SIM	EPA 8270D EPA 8270D SIM
Dibenzofuran	EPA 8270D	EPA 8270D
1,2-Dichlorobenzene	EPA 8270D	EPA 8270D
1,3-Dichlorobenzene	EPA 8270D	EPA 8270D
1,4-Dichlorobenzene	EPA 8270D	EPA 8270D
3,3'-Dichlorobenzidine	EPA 8270D	EPA 8270D
2,4-Dichlorophenol	EPA 8270D	EPA 8270D
2,6-Dichlorophenol	EPA 8270D	EPA 8270D
Diethyl Phthalate	EPA 8270D	EPA 8270D
2,4-Dimethylphenol	EPA 8270D	EPA 8270D
Dimethyl Phthalate	EPA 8270D	EPA 8270D
di-n-Butyl Phthalate	EPA 8270D	EPA 8270D
di-n-Octyl Phthalate	-----	EPA 8270D
2,4-Dinitrophenol	EPA 8270D	EPA 8270D
2,4-Dinitrotoluene	EPA 8270D	EPA 8270D
2,6-Dinitrotoluene	EPA 8270D	EPA 8270D
Fluoranthene	EPA 8270D EPA 8270D SIM	EPA 8270D EPA 8270D SIM
Fluorene	EPA 8270D EPA 8270D SIM	EPA 8270D EPA 8270D SIM
Hexachlorobenzene	EPA 8270D	EPA 8270D
Hexachlorobutadiene	EPA 8270D	EPA 8270D
Hexachlorocyclopentadiene	EPA 8270D	EPA 8270D
Hexachloroethane	EPA 8270D	EPA 8270D
Indeno(1,2,3-cd)pyrene	EPA 8270D EPA 8270D SIM	EPA 8270D EPA 8270D SIM
Isophorone	EPA 8270D	EPA 8270D

<u>Parameter/Analyte</u>	<u>Solid & Chemical Materials</u>	
	<u>Aqueous</u>	<u>Solid</u>
1-Methylnaphthalene	EPA 8270D EPA 8270D SIM	EPA 8270D EPA 8270D SIM
2-Methylnaphthalene	EPA 8270D EPA 8270D SIM	EPA 8270D EPA 8270D SIM
2-Methyl-4,6-dinitrophenol	EPA 8270D	EPA 8270D
2-Methylphenol (As O cresol)	EPA 8270D	EPA 8270D
3 & 4-Methylphenol (As P & M cresol)	EPA 8270D	EPA 8270D
Naphthalene	EPA 8270D EPA 8270D SIM	EPA 8270D EPA 8270D SIM
2-Nitroaniline	EPA 8270D	EPA 8270D
3-Nitroaniline	EPA 8270D	EPA 8270D
4-Nitroaniline	EPA 8270D	EPA 8270D
Nitrobenzene	EPA 8270D	EPA 8270D
2-Nitrophenol	EPA 8270D	EPA 8270D
4-Nitrophenol	EPA 8270D	EPA 8270D
n-Nitrosodimethylamine	EPA 8270D	EPA 8270D
n-Nitrosodi-n-propylamine	EPA 8270D	EPA 8270D
n-Nitrosodiphenylamine	EPA 8270D	EPA 8270D
Pentachlorophenol	EPA 8270D	EPA 8270D
Phenanthrene	EPA 8270D EPA 8270D SIM	EPA 8270D EPA 8270D SIM
Phenol	EPA 8270D	EPA 8270D
Pyrene	EPA 8270D EPA 8270D SIM	EPA 8270D EPA 8270D SIM
Pyridine	EPA 8270D	EPA 8270D
1,2,4-Trichlorobenzene	EPA 8270D	EPA 8270D
2,4,5-Trichlorophenol	EPA 8270D	EPA 8270D
2,4,6-Trichlorophenol	EPA 8270D	EPA 8270D
<u>Pesticides/Herbicides/PCBs</u>		
Aldrin	EPA 8270D SIM	EPA 8270D SIM
alpha-BHC	EPA 8270D SIM	EPA 8270D SIM
alpha-Chlordane	EPA 8270D SIM	EPA 8270D SIM
beta-BHC	EPA 8270D SIM	EPA 8270D SIM
delta-BHC	EPA 8270D SIM	EPA 8270D SIM
gamma-BHC	EPA 8270D SIM	EPA 8270D SIM
gamma-Chlordane	EPA 8270D SIM	EPA 8270D SIM
Chlordane (technical)	EPA 8270D SIM	EPA 8270D SIM
4,4'-DDD	EPA 8270D SIM	EPA 8270D SIM
4,4'-DDE	EPA 8270D SIM	EPA 8270D SIM
4,4'-DDT	EPA 8270D SIM	EPA 8270D SIM
Dieldrin	EPA 8270D SIM	EPA 8270D SIM
Endosulfan I	EPA 8270D SIM	EPA 8270D SIM
Endosulfan II	EPA 8270D SIM	EPA 8270D SIM
Endosulfan Sulfate	EPA 8270D SIM	EPA 8270D SIM
Endrin	EPA 8270D SIM	EPA 8270D SIM

<u>Parameter/Analyte</u>	<u>Solid & Chemical Materials</u>	
	<u>Aqueous</u>	<u>Solid</u>
Endrin Aldehyde	EPA 8270D SIM	EPA 8270D SIM
Endrin Ketone	EPA 8270D SIM	EPA 8270D SIM
Heptachlor	EPA 8270D SIM	EPA 8270D SIM
Heptachlor Epoxide	EPA 8270D SIM	EPA 8270D SIM
Methoxychlor	EPA 8270D SIM	EPA 8270D SIM
PCB-1016 (Aroclor)	EPA 8082A	EPA 8082A
PCB-1221 (Aroclor)	EPA 8082A	EPA 8082A
PCB-1232 (Aroclor)	EPA 8082A	EPA 8082A
PCB-1242 (Aroclor)	EPA 8082A	EPA 8082A
PCB-1248 (Aroclor)	EPA 8082A	EPA 8082A
PCB-1254 (Aroclor)	EPA 8082A	EPA 8082A
PCB-1260 (Aroclor)	EPA 8082A	EPA 8082A
Semivolatle Extraction Methods	EPA 3520C Modified EPA 3535A	EPA 3550C EPA 3665A
Toxaphene	EPA 8270D SIM	EPA 8270D SIM
Toxicity Characteristic Leaching Procedure	EPA 1311	EPA 1311
<u>Hazardous Waste Characteristics</u>		
Corrosivity	EPA 9040C	EPA 9045D
Ignitability	EPA 1020B	-----



Accredited Laboratory

A2LA has accredited

SGS NORTH AMERICA INC. - ALASKA DIVISION
Anchorage, AK

for technical competence in the field of
Environmental Testing

In recognition of the successful completion of the A2LA evaluation process that includes an assessment of the laboratory's compliance with ISO/IEC 17025:2017, the 2009 TNI Environmental Testing Laboratory Standard, and the requirements of the Department of Defense Environmental Laboratory Accreditation Program (DoD ELAP) as detailed in version 5.4 of the DoD/DOE Quality System Manual for Environmental Laboratories (QSM), accreditation is granted to this laboratory to perform recognized EPA methods as defined on the associated A2LA Environmental Scope of Accreditation. This accreditation demonstrates technical competence for this defined scope and the operation of a laboratory quality management system (refer to joint ISO-ILAC-IAF Communiqué dated *April 2017*).



Presented this 9th day of December 2021.

A blue ink signature of a person, written over a horizontal line.

Vice President, Accreditation Services
For the Accreditation Council
Certificate Number 2944.01
Valid to December 31, 2023

For the tests to which this accreditation applies, please refer to the laboratory's Environmental Scope of Accreditation.

ATTACHMENT 5
RESUMES

This page intentionally blank

QUINN MEEHAN, PG	PROGRAM MANAGER
-------------------------	------------------------

Mr. Meehan has nearly 20 years of experience as an environmental professional (Geologist and Project/Program Manager) throughout Alaska, the Pacific Northwest, and Hawaii. Quinn’s experience spans the range of the remedial process from site characterization to Decision Documents/Records of Decision, remedial action, and long-term monitoring and NAPL recovery programs. He has performed and managed this work in Alaska for a variety of federal and private sector markets, including oil and gas and Kenai Peninsula projects. He has executed and managed environmental projects in remote and austere Alaska locations with inclement conditions and complex logistics. He successfully communicates and coordinates with a variety of clients, regulatory agencies, stakeholders, and contractors. As a manager he works directly with the client to meet project objectives; assembles and unites the project team; supervises and mentors field and office personnel; provides overall oversight of subcontractors; directs, tracks, and delivers the project scope; coordinates project-specific and schedule requirements; ensures overall health/safety/environmental and policy/regulatory compliance; prepares proposals and cost estimates; and handles the financial and administrative aspects of a project.

EDUCATION/QUALIFICATIONS

<p>Total Cumulative Years: 19 Employer: ARS Aleut Remediation, LLC Present Position/Title: Program/Project Manager US Citizen: Yes Education: B.S., Geology, University of Washington, 2004</p>	<p>Certifications: State of Alaska Professional Geologist (PG, No. 112679); American Institute of Professional Geologists Certified Professional Geologist (CPG, No. 11836) Relevant Training: NSTC North Slope Unescorted + Hydrogen Sulfide Safety Training, Alyeska Pipeline Safety Training, PFAS Field Sampling Training, OSHA HAZWOPER 8-hr Site Supervisor Training; OSHA HAZWOPER 8-hr refresher Training; OSHA HAZWOPER 40-hr Training; ATV Safety Institute course per EM-385-1-1; Dakota Technologies LIF Data Interpretation</p>
--	---

RELEVANT EXPERIENCE

Program/Project Manager, Hilcorp Alaska and Hilcorp North Slope, Program Management and Chemistry Support, Variety of Kenai Peninsula, Cook Inlet, and Prudhoe Bay Sites, AK. Currently manages program and chemistry support provided to Hilcorp Alaska and Hilcorp North Slope environmental programs. Support includes accrual tracking, file structure development and management, technical document reviews, regulator correspondence, environmental GIS database and web-map development, QAPP generation, chemical data quality reviews, database queries, and reporting support. Includes support of BCU4, CLU3, KGF, and SRF. Provides technical consultation, coordinates the team, and performs all administrative aspects of the projects.

Project Manager, Hilcorp Kenai Peninsula Waste Sites Groundwater Monitoring Program, SRF Grind and Inject Facility, Kenai Peninsula, AK. Project Manager for a long-term groundwater monitoring project at a waste storage facility. Monitoring included visual inspections, well maintenance, gauging, and groundwater sampling. Collaborated with the client, established the team, oversaw all aspects of the work, and provided document reviews. All work was completed on time and under budget.

Project Manager, Hilcorp, Farm Yard Spill, Kenai, AK. Project Manager for spill response activities associated with a 200-gallon hydraulic oil spill. Collaborated with the client and team, oversaw all aspects of the work, and provided data and document reviews. All work was completed on time and under budget.

Project Manager, GE Oil and Gas, Phase I and Phase II ESA, Kenai, AK. Managed and performed Phase I and Phase II ESAs across two Kenai properties. Worked closely with client on facility operation details, environmental goals of existing facility, and acquisition of neighboring property. Performed detailed records reviews, interviewed and coordinated with facility operators, performed visual inspections,

oversaw soil boring and monitoring well installation, developed monitoring wells, low-flow groundwater sampling, collected soil and groundwater samples, and characterized septic tank conditions. All work was completed on time and under budget.

Program Manager, Heavy Equipment Supplier, Environmental Services, Alaska and Pacific Northwest Facilities. Program Manager for a major northwest heavy equipment supply and maintenance provider. Provided groundwater investigation, long term groundwater monitoring, LNAPL recovery, Phase I/II, and Stormwater Prevention, Control, and Countermeasure services. Negotiated Decision Document with State agency and subsequently attained site closure for benzene groundwater issue.

Project Manager, USACE, RI, Cold Bay, AK. Project Manager of a multi-year RI performed at a former military facility comprising over 1000 acres. Field work was performed over two seasons, with each event spanning over 100 consecutive days. A total of 350 sites were investigated. Field work included completion of over 2,000 UVOST, 550 soil borings, 100 passive soil gas samplers, 50 Incremental Sampling Methodology samples, EM-61 and ground penetrating radar (GPR) geophysical surveys, land surveys, and the collection of more than 500 analytical soil samples.

Project Manager, USACE, RI, Kodiak, AK. Project Manager for a follow-on RI at a former aviation gasoline (AVGAS) underground tank farm. Delineating the nature and extent of AVGAS and chlorinated solvent contamination in soil, groundwater, surface water, and sediment. Integral in planning drill rig access across steep terrain in order to fill data gaps from previous RI. The Contractor Performance Assessment Report indicated exceptional ratings for quality, schedule, and management: *“work quality during execution of this task order has been exceptional.”* The project was completed on time and under budget.

Project Manager, USACE, RI, Yakutat, AK. Project Manager for RI at seven areas of concern, including a landfill, former aboveground storage tanks (ASTs), and former power plants. Quinn’s management and proactive approach was reflected through client feedback on the project: *“Contractor has been actively communicating with the USACE PDT and ADEC. Frequent back and forth communication about technical details...allowed for a scientific based rationale to be developed and proposal of no further action for three sites. This is expected to save the Government millions of dollars in unnecessary cleanup costs.”*

Project Manager, USACE, RI/FS/PP, Kruzof Island, AK. Project Manager, Field Manager, and Technical Lead for RI/FS/PP at a former military site on a remote island outside of Sitka. The RI was conducted in two phases and included site inspections; soil, sediment, groundwater, and surface water sampling; and geophysical survey to evaluate drums, AST, power plant, septic tanks, and a landfill. Involved in all aspects of planning and management of project tasks, which required evaluating many challenging logistical considerations including site access, sample shipment, and communications from a remote uninhabited location.

Project Manager, U.S. Army Corps of Engineers (USACE), RI and Removal Action, Cape Yakak, Adak Island, AK. Project Manager of a RI and soil/waste removal action project at a former WWII military facility on Adak Island. Over 50 separate sites were investigated, and 540 tons of hydrocarbon/lead impacted soil and waste debris removed. The RI included groundwater and surface water investigations. Established team, lead waste management activities, and oversaw all aspects of the project.

Geologist, Chevron, Long-Term Monitoring, Swanson River, AK. Performed facility coordination, visual inspections, groundwater and surface water sampling, and reporting long-term monitoring activities to address xylenes at the Swanson River Field.

Geologist, Shell, Long-Term Monitoring, Multiple Sites, WA. Geologist for a long-term monitoring program across more than 20 mid-stream and downstream assets. Performed planning, facility coordination, visual inspections, groundwater sampling, liquid level gauging, passive and active LNAPL recovery, and reporting. Conducted sample management including labeling, packing, and shipping samples under proper chain-of-custody.

SARA HADDEN PROJECT MANAGER

Ms. Hadden brings over 20 years of diverse work experience in the environmental field, where she has technical expertise with numerous aspects of the planning and execution of environmental compliance and remediation projects. She has performed environmental investigations and remediation on various projects. Project scopes have included Preliminary Assessments, Site Investigations, Remedial Investigations, Feasibility Studies, Decision Documents, removal actions, remediation, and long-term monitoring projects. She has a working knowledge of federal, state, and local laws, regulations, and guidance, including CERCLA, RCRA, TSCA, CAA, CWA, 18 AAC 60, 18 AAC 75, and 18 AAC 78.

Sara brings the background and breadth of experience necessary to successfully plan for and manage the execution of environmental investigations across the state of Alaska. She will use her knowledge of relevant state and federal guidelines; sampling methods; and contaminant fate and transport to ensure regulatory compliance and support client objectives and decision-making.

EDUCATION/QUALIFICATIONS

<p>Total Cumulative Years: 20 Employer: ARS Aleut Remediation, LLC Present Position/Title: Project Manager/Environmental Scientist US Citizen: Yes Education: M.S., Environmental Quality Science, 2004, University of Alaska Anchorage; B.S., Biology, Southern Oregon University, 2001; A.S. Science, Cottey College, 1998.</p>	<p>Certifications: ADEC-Qualified Environmental Professional Relevant Training: OSHA 40-hr-Hazardous Site Training (with annual 8-hour refresher); OSHA 8-hr Site Manager and Supervisor Training for Hazardous Site Operations and Emergency Response; 30-hr OSHA Construction Outreach Training; OSHA Excavation Competent Person; USACE Construction Quality Management for Contractors; DOT Hazardous Materials Transportation; IATA Dangerous Goods Transportation; Lead Risk Assessor Certification; AHERA Building Inspector Certification; Bear Awareness Training; First Aid/CPR/AED; Niton XRF Analyzer Operator training; Managing Uncertainty with Systematic Planning for Environmental Decision Making</p>
--	---

RELEVANT EXPERIENCE

Project Manager, Delta Western, Rocky Point Management Area (RPMA) Groundwater Monitoring and Operations and Maintenance (O&M) Support; Dutch Harbor, AK. Sara works with, manages, and supports the current local environmental subcontractor for this project on behalf of Delta Western. This project includes the execution of long-term monitoring and O&M activities for the RPMA in Dutch Harbor, Alaska, which involves groundwater sampling, product recovery, surface water sampling, and sediment sampling, as well as the O&M of oil-water separators at the site. Sara coordinates with the local subcontractor to expedite accurate and efficient sampling and O&M activities, and coordinates with the analytical laboratory for glassware orders as well as sample receipts. In 2022, Sara spent time in the field with the local subcontractor to mentor the field staff in proper sample collection and handling. Sara also manages reporting and data management including the completion of ADEC checklists and generating the annual reports to document each season’s sampling and O&M activities.

Environmental Scientist/Chemist, Hilcorp Contaminated Sites Groundwater Monitoring and Optimization Support, Kenai, AK. This \$1M groundwater monitoring and optimization program involved 175 wells at 16 AOCs in Kenai. Sara supported the biennial sampling program which included the planning, field implementation, and reporting efforts. Sara also supported the review of nearly 20 years of environmental records to optimize Hilcorp’s 230 wells requiring data collection to 175 wells.

Environmental Scientist, Hilcorp North Slope Environmental Program Support, Prudhoe Bay, AK. This project included updating the RCRA program QAPP for the Prudhoe Bay facility recently acquired by Hilcorp to be more efficient and effective and in line with Hilcorp’s management strategies. The RCRA program includes the management, investigation, and sampling of numerous EPA and ADEC regulated

sites at the North Slope facility and involves working closely with the various subcontractors that have been paramount to the execution of this work. Sara provided technical support as well as chemistry support including coordination with analytical laboratories and sample and data management and review.

Environmental Scientist/Chemist, Hilcorp Waste Sites and Site Closure Support, Kenai, AK. This \$200K project included the well installation, development, and sampling of waste site wells in addition to ensuring that the facility permits were maintained in compliance with ADEC solid waste requirements. This project grew into the development of closure documentation to assist Hilcorp in retiring their waste facilities. Closure efforts included conducting statistical analyses based on the evaluation of historical data trends to obtain closure of sites for Hilcorp. Sara managed tasks toward the successful closure of the Beaver Creek Unit Drilling Waste Disposal site as well as a second closure by ADEC at the Swanson River Central Drilling Waste Facility. Sara also supported the annual waste sampling program for three waste sites across two of Hilcorp's development units.

Project Manager/Technical Lead, FAA/USACE/USCG, Annette Island, AK. This project included site investigation and remediation activities, as well as long-term groundwater monitoring activities. As the Project Manager, Sara was responsible for coordinating Closure and After Action reporting activities, ensuring the generation of quality documents, and managing the budget and schedule. Sara was responsible for the closeout of this project and managed the budget to zero dollars to ensure the best value to the client. Sara managed the annual groundwater monitoring program which involved the planning for, execution of, and reporting on sample collection of over 50 groundwater monitoring wells. She developed a decision tree to systematically remove wells from the sampling program to benefit the client's objectives. The decision tree was approved by the local regulatory agency (MIC) and the number of wells sampled on an annual basis was reduced from over 50 to 30. Sara led excavation, sample collection, and sample management activities, managed subcontractors on site, and authored After Action and Closure Reports.

Technical Lead/Environmental Scientist, USACE, Amaknak Pre-WWII Tank Farm FUDS, Unalaska, Alaska. This project included optimization of the groundwater monitoring program at the Pre-WWII Tank Farm FUDS in Amaknak, as well as the completion of a five-year review. Work included an upgrade of onsite remedies, groundwater network optimization, and groundwater gauging and sampling. Sara managed the generation of multiple deliverables including a Groundwater Monitoring Optimization and Sampling Plan, an Annual Groundwater Report, a Periodic Review, a Groundwater Use Determination Memorandum, and a GIS database for public use. Sara also served as the Project Manager for this project during the field effort.

Environmental Scientist, USACE, FUDS Groundwater Sampling at Nome, Tok, Big Delta, and Northway, AK. Sara supported this multi-year project during the planning and reporting phases. Tasks included updating existing planning documents and authoring long-term monitoring reports and periodic reviews (27 report versions in total); providing support to multiple project teams in performing fieldwork, which included monitoring well development at six wells, groundwater sampling at 52 wells, drinking water sample collection, and data downloads from pressure transducers.

Ms. Mattice has 5 years of environmental remediation experience. She has performed various stages of the remedial process, such as Site Inspections, Site Characterization, Remedial Investigations, Work Plans, and Remedial Actions. Her areas of technical expertise as a Technical Lead/Geological Engineer on large- and small-scale projects include fieldwork execution, document production, groundwater sampling, surface water sampling, monitoring well inventory, product recovery, procurements, remote logistics planning and management, and sample management. Nicole has remote/austere experience throughout Alaska in locations such as Swanson River Oil Field (SRF), Kenai Gas Field (KGF), Cannery Loop Unit Pad 3 (CLU3), and Beaver Creek Unit Pad 4 (BCU4) on the Kenai Peninsula, Northway Village, Tok, and Cold Bay.

EDUCATION/QUALIFICATIONS

Total Cumulative Years: 5
Employer: ARS Aleut Remediation, LLC
Present Position/Title: Geological Engineer
US Citizen: Yes
Education: B.S., Geological Engineering with emphasis in Environmental and Petroleum Engineering, Missouri University of Science and Technology, 2017

Certifications: Engineer-in-Training (EIT); ADEC-Qualified Environmental Professional
Relevant Training: OSHA HAZWOPER 40-hr Training; OSHA HAZWOPER 8-hr refresher Training; ATV Safety course; 49 CFR DOT Hazardous Materials Transportation; ICAO/IATA Dangerous Goods Transportation; Wildlife Awareness Training; Delayed Care First Aid/CPR/AED; USACE Construction Quality Management for Contractors Certificate; Confined Space Entry Training

RELEVANT EXPERIENCE

Technical Lead/Field Lead/Geological Engineer, Hilcorp Contaminated Sites Long-Term Groundwater Monitoring Program, SRF Tank Settings (TS), SRF Electric Shop, KGF, BCU4, and CLU3, Kenai Peninsula, AK. Technical and Document Lead during 2019-2022 reporting and planning seasons for SRF TS, SRF Electric Shop, KGF, BCU4, and CLU3. Lead author for all 2019, 2021, and 2022 Groundwater Monitoring Work Plans and Groundwater Monitoring Reports for Alaska Department of Environmental Conservation (ADEC) approval. Evaluated optimizations to the groundwater monitoring program in all 2019-2021 reports and further evaluated the program’s optimizations in 2021 by performing Mann-Kendall trend analysis for all sites. Performed as Field Lead in 2021 and field sampler in 2019 for all sites, which included 7 TS units at SRF, 1 former tank area at the SRF Electric Shop, and 6 oilfield pads across 4 sites (KGF, BCU4 North and South, and CLU3) on the Kenai Peninsula, Alaska. A combined total of 195 monitoring wells were included in the groundwater monitoring program and the activities performed included groundwater gauging, monitoring well inspections and maintenance, groundwater and surface water sample collection, product recovery and monitoring, and visual site assessments. Coordinated with oilfield personnel daily to complete work permits, conduct safety briefings, flare pit supervision/safety when applicable, and simultaneous operations awareness. Maintained the field schedule while adjusting as needed for reasons such as accommodating client site visits as they became available, simultaneous oilfield operations, smaller field team than scheduled, working around client trainings, and wildlife interferences/obstructions. Procured field supplies and rental sampling equipment and prepared a team of 5 for remote work. Arranged vehicle and lodging accommodations. Communicated with client daily to provide completed activities updates, next day activities planned, schedule concerns (if any), and safety observations. Closely monitored fatigue management of field crew due to hot temperatures, long working hours, and extensive schedule. Managed more than 800 groundwater and surface water samples. Lead waste management tracking and disposal. Coordinated land surveying for all wells that required surveying.

Geological Engineer/Field Sampler, Hilcorp, Kenai Peninsula Waste Sites Groundwater Monitoring Program, SRF Grind and Inject Facility, Kenai Peninsula, AK. Organized vehicle and lodging logistics for one-week field effort. Procured field supplies and rented sampling equipment prior to mobilization in preparation for remote work. Conducted groundwater gauging and sampling at 6 monitoring wells. Tracked, packaged, and shipped approximately 60 groundwater samples. Tracked waste management and organized waste for proper disposal. Authored the 2019 Groundwater Monitoring Report for ADEC approval.

Geological Engineer, Hilcorp General Support, Prudhoe Bay and Kenai Peninsula, AK. Provided technical guidance regarding the potential need to replace a Kenai Peninsula monitoring well. Assisted with the Prudhoe Bay Unit environmental program presentation materials.

Geological Engineer/Field Lead/Field Sampler, USACE, RCRA Long Term Monitoring, Site 1 Landfill, and Sites 3, 6A, and 7A, Kodiak, AK. Quarterly monitoring program for hazardous waste management units. Performed as Field Lead during the Q4 groundwater sampling and surface water sampling event for Site 1 Landfill. Performed as field sampler for all other sites. Organized logistics, such as vehicle rental, crew lodging, and shipping supplies and equipment via Alaska Air Cargo. Field activities performed at Sites 1, 3, 6A, and 7A during each event included gauging and monitoring well inspections of 69 monitoring wells, collecting groundwater samples from 27 monitoring wells, collecting 3 surface water samples, and conducting a monitoring well inventory of all 370 monitoring wells on the property.

Geological Engineer/Field Sampler, USACE, Nike Site Bay Formerly Used Defense Site (FUDS) F10AK0850, Project 03 Hazardous, Toxic, and Radioactive Waste, Remedial Investigation and Remedial Action, Goose Bay, AK. Authored the 2021 Remedial Investigation Work Plan. Lead the 2-week groundwater sampling field effort at a remote site in the Knik Arm of Alaska inaccessible by vehicle. Independently collected groundwater samples from 36 monitoring wells using low-flow methods and developed 6 newly installed monitoring wells. Additionally, supported geophysical investigation through ground penetrating radar, deployed and collected 80 passive soil gas samplers, and collected 10 incremental sampling methodology soil samples. Procured and mobilized supplies and equipment for each groundwater sampling event.

Project Engineer/Field Sampler, USACE, FUDS Long-Term Groundwater Monitoring Program, Haines-Fairbanks Pipeline Gate Valve #52 and Timber Pump Station, Northway Staging Field (Ham Lake), Northway Alaska Communication System, Tok, Delta Junction, and Northway Junction, AK. Organized vehicle and lodging logistics for each field effort, approximately one week each. Procured field supplies, rented sampling equipment, and prepared team for remote work. Conducted groundwater gauging and sampling at a combined total of 40 monitoring wells across 4 sites. Performed site inspections at 2 sites investigating current land use, institutional controls, site disturbances, and monitoring well conditions. Packaged and shipped all groundwater samples to analytical laboratory. Authored the 2018 Groundwater Sampling Reports for ADEC approval.

Geological Engineer, USACE, Umiat Test Well #7 FUDS Feasibility Study, Umiat, AK. Co-authored the Feasibility Study. Researched site history and previous investigations at Umiat, Alaska. Developed the Conceptual Site Model based on potential human, animal, and plant interactions with remaining contamination. Coordinated with GIS team to design feasibility study figures depicting site location and features, previous soil sampling locations, and historic analytical results.

KYLE THERRIEN	SURVEY/GIS/GEOLOGIST
----------------------	-----------------------------

Mr. Therrien is a Qualified Environmental Professional with five years of experience in contaminated site characterization and cleanup; three and a half years of experience as a Geologist. He is experienced working in remote locations, including the Swanson River Oil Field (SRF), Kenai Gas Field (KGF), Cannery Loop Unit Pad 3 (CLU3), and Beaver Creek Unit Pad 4 (BCU4) on the Kenai Peninsula, and has a solid understanding of the critical role safety and environmental awareness plays in the success of projects. He has extensive experience working as a Geologist on large- and small-scale projects across Alaska, for clients including Hilcorp, USACE, AFCEC, FAA, USCG, and AKARNG.

EDUCATION/QUALIFICATIONS	
---------------------------------	--

<p>Total Cumulative Years: 8 Employer: ARS Aleut Remediation, LLC Present Position/Title: Geologist/Survey/GIS US Citizen: Yes Education: B.S., Geological Sciences, University of Alaska, Anchorage, 2015</p>	<p>Certifications: Young Professional Member, American Institute of Professional Geologists, Alaska, MEM-2921. Relevant Training: FAA Remote Pilot Standard CFR 107 UAS Pilot License; USACE Construction Quality Management for Contractors Certificate; NSTC North Slope Unescorted + Hydrogen Sulfide Safety Training; HAZWOPER 40-hr and 8-hr refresher, HAZWOPER Supervisor 8-hr; OSHA Construction 30-hr; First Aid/CPR/AED; OSHA Confined Spaces Training, DOT Hazardous Materials Transportation; IATA Dangerous Goods Transportation Section 1.5 and 49 CFR 172.700-172.704; North Slope Training Cooperative Course; Wilderness First Responder by LTR Training Services, Inc; Wildlife Awareness and Defense by LTR Training Services, Inc; Remote Worker Ice Safety and Rescue Training by Alaska Rescue</p>
---	---

RELEVANT EXPERIENCE

Geologist/Geospatial Specialist, Hilcorp Contaminated Sites Long-Term Groundwater Monitoring Program, SRF Tank Settings (TS), SRF Electric Shop, KGF, BCU4, and CLU3, Kenai Peninsula, AK. Performed as geospatial data management lead during 2017-2020 reporting and planning seasons for SRF TS, SRF Electric Shop, KGF, BCU4, and CLU3. Performed as geologist/field sampler during the 2019 and 2017 fieldwork for all sites, which included 7 TS units at SRF, 1 former tank area at the SRF Electric Shop, and 6 oilfield pads across 4 sites (KGF, BCU4 North and South, and CLU3) on the Kenai Peninsula, Alaska. A combined total of 195 monitoring wells were included in the groundwater monitoring program and the activities performed each event included groundwater gauging, monitoring well inspections and maintenance, groundwater sample collection, surface water sample collection, product recovery and monitoring, and visual site assessments. Coordinated with oilfield personnel daily to complete work permits, conduct safety briefings, identify the need for supervision when conducting work in flare pits, and to notify of simultaneous operations. Provided geospatial data management and generated figures for the 2017 and 2019 Groundwater Monitoring Work Plans for SRF TS, SRF Electric Shop, KGF, BCU4, and CLU3. Provided geospatial data management and generated figures for all five 2019 Groundwater Monitoring Reports for Alaska Department of Environmental Conservation (ADEC) approval and supported the four 2017 Groundwater Monitoring Reports.

Geologist, Hilcorp Kenai Peninsula Waste Sites Groundwater Monitoring Program, SRF Grind and Inject Facility, Kenai Peninsula, AK. Performed field sampling activities for a long-term groundwater

monitoring project at a waste storage facility. Evaluated chemical data and prepared reporting documents for ADEC review and approval. Authored the 2022 Groundwater Monitoring Report for ADEC approval.

Geologist/Field Sampler, Hilcorp Farm Yard Spill, Kenai Peninsula, AK. Conducted waste characterization sampling for soils excavated and containerized during a spill response for a 200-gallon hydraulic oil spill.

Field Team Lead/UAV Pilot/Surveyor, BLM Mining Claims Site Inventory and Removal Actions, various sites. This \$2 million project included the planning and execution of a systematic inventory of over 250 abandoned mining claims located throughout Alaska in preparation for transfer of ownership these claims to the State of Alaska. Kyle worked with the team to coordinate the complex mobilizations over two field seasons, requiring barges, UTVs, and helicopters to reach remote sites. Originated and developed technical capabilities for the company specifically to execute this project, including the addition of fixed-wing UAVs to expedite the acquisition of aerial imagery. Produced over 5,000 acres of orthomosaic imagery to document mining claim status. This project required close coordination amongst many stakeholders including BLM, USACE, DNR, and local villages. A removal action was also conducted under this contract which included the removal and disposal of various hazardous building materials, the demolition and removal of a garage structure, and the excavation and disposal of POL-contaminated soil. Kyle supported the work planning, reporting efforts, and led crews while in the field.

Geologist, FAA Former Farewell Station, Remedial Investigation and Action, Farewell, AK. Executed pre-sampling stakeout using RTK and post-sampling surveying of new sample locations, including daily set-up of survey equipment and check shots. Drill rig (Geoprobe 6620 direct push) assistant/geologist tasked with field screening and sampling 74 soil borings and installing temp wells at 11 areas of concern. Conducted rotocopter UAS flights to collect orthomosaic imagery for reporting purposes. Contributed to planning, field implementation, geospatial data management, and reporting efforts.

Geologist/Field Sampler, Adak Public Works Building Monofil Groundwater Monitoring, T1470 Inert Waste Monofill, Adak, AK. Led two groundwater sampling field efforts in May and November by collecting groundwater samples from three monitoring wells using low-flow methods. Utilized electronic field forms for monitoring well inspection, gauging, and low-flow sampling activities. Conducted sample management including labeling, packing, and shipping samples under proper chain-of-custody. Authored the 2022 Groundwater Monitoring Report, which included remedial activities such as monitoring well condition documentation, groundwater sampling, groundwater gauging, UAV orthomosaic imagery collection, soil cuttings characterization sampling, and site survey.

Geologist/Geospatial Specialist, USACE, Nike Site Bay FUDS Remedial Investigation, Goose Bay, AK. Through multiple contracts this project has included the extensive investigation of chlorinated volatile organic carbon contamination in soil, groundwater, and soil gas at Nike Site Bay located outside Wasilla, Alaska. During Phase I, executed pre-sampling location stakeout using survey RTK methods for soil and groundwater sampling plans based on a site wide gridded system. Contributed to planning, field implementation, and reporting efforts. During Phase II, provided geospatial data management and figure generation to support RI work plan for delineating chlorinated solvent contamination. Supported the development of a sampling approach to collect data needed to determine the nature and extent of contamination. Remedial investigation field work consisted of three mobilizations. Acted as geologist/qualified sampler for the duration of the remedial investigation which consisted of drilling five deep wells in a secondary aquifer, thirteen shallow wells in a perched aquifer, forty soil borings, three geotechnical soil borings, two temporary wells, and sixteen discrete surface soil samples.

Geospatial Specialist/ Drilling Assistant, AFCEC PFOA/PFOS and Comingled PFOA/PFOS/POL F35 Soil Stockpiles Characterization Sampling at Eielson Air Force Base, AK. Assisted with ISM sampling of nine soil stockpiles for PFAS/PFOA and hydrocarbon compounds, characterizing 10,600 cubic yards of soil during the pilot study. Work was conducted in adverse freezing conditions, which required strategic decisions to complete the pilot study successfully.

KARINA PACKER, PE	PROJECT ENGINEER
--------------------------	-------------------------

Ms. Packer brings over seven years of work experience in the environmental field, where she has diverse field project experience throughout Alaska. At ARS Aleut Remediation, LLC (Aleut), Karina is a Registered Professional Environmental Engineer (PE) involved in front-end planning as well as fieldwork, report writing, and engineering design. Her field experience includes several large, multi-year groundwater monitoring efforts, soil boring and monitoring well installation, spill response, air sampling, surveying, sample management, O&M of remedial systems, and third-party construction QA oversight. Karina has prior experience working through all stages of the CERCLA process, including site investigations, feasibility studies, and long-term operation/monitoring for clients such as USACE, AFCEC, and USCG. Karina has been consistently supporting Hilcorp for the past four years, including performing groundwater monitoring at Kenai Peninsula Sites.

EDUCATION/QUALIFICATIONS

<p>Years In Proposed Position: 7 Total Cumulative Years: 11 Employer: ARS Aleut Remediation, LLC Present Position/Title: Project Engineer US Citizen: Yes Education: B.E. with Mechanical Focus, Thayer School of Engineering at Dartmouth College, 2015. B.A. in Engineering Sciences, Dartmouth College, 2015</p>	<p>Certifications: Environmental PE (EV- 153395), Relevant Training: North Slope Training Cooperative -Unescorted; OSHA 40-hr-Hazardous Site Training (with annual 8-hour refresher); Contractor Construction Quality Management; DOT Hazardous Materials Transportation; IATA Dangerous Goods Transportation; First Aid/CPR/AED; ADEC-Qualified Environmental Professional</p>
--	--

RELEVANT EXPERIENCE

Project Engineer/Field Lead, Hilcorp Kenai Peninsula Waste Sites Groundwater Monitoring Program, SRF Grind and Inject Facility, Kenai Peninsula, AK. Led the field effort for annual groundwater monitoring effort at the G&I Pad at Swanson River in 2020, 2021, and 2022. Performed monitoring well redevelopment, general site and monitoring well inspections, monitoring well maintenance such as cutting down casings of frost-jacked wells, groundwater gauging, groundwater sampling, and sample management. Karina applied lessons learned during each subsequent event for improved field efficiencies and used Aleut’s digital forms during the 2022 event for added quality checks and streamlined reporting. Authored the 2020 Groundwater Monitoring Report for ADEC approval and assisted with the 2021 and 2022 reports.

Air Compliance Technician, Hilcorp Alaska and Hilcorp North Slope Air Compliance Program Support. Ongoing support for the Air Compliance group for Hilcorp Alaska LLC. and Hilcorp North Slope LLC. Includes familiarity with all Alaska-based facilities, required reporting assistance, and general team support. Covered one of the three Air SME positions for 7 cumulative months in 2022, providing Air Compliance support for East Prudhoe Bay Unit Facilities and the Alaskan Islands. Accompanied ADEC Inspector for 2022 FCE Inspections at seven Prudhoe Bay Unit facilities.

Project Engineer/Field Sampler, Hilcorp Stump Lake Spill Response, Beluga River Unit, Alaska. Assisted a spill response effort in Beluga River by providing field screening to direct excavation efforts and confirmation sampling following excavation. Performed sample management including labelling, packaging, and shipping under proper chain-of-custody. Authored the Closure Report, which received a “No Further Action” designation from ADEC in 2020. Following the spill response effort, conducted a unit-wide survey of existing monitoring wells to assess usability and identify gaps for development of a groundwater sampling plan.

Project Engineer/Field Sampler, Installation-Wide Monitoring Program, Eielson AFB, Alaska. Performed semi-annual groundwater monitoring at Eielson Airforce Base 2015-2018. Coordinated personnel and equipment mobilizations from both Anchorage and Fairbanks. Performed sample management duties including sample tracking, quality checks, labelling, maintaining sample temperature,

cooler packaging, chain-of custody, shipment, and laboratory coordination. Worked with team during reporting to optimize subsequent monitoring events, including identifying areas of efficiency and reducing number of wells sampled.

Project Engineer/Technical Lead, Buskin Beach Lube Pits Monitoring Well Installation and AS/SVE Pilot Study, Kodiak, AK. Performed multiple site visits for information gathering and inspections and led field teams during three separate mobilizations to complete delineation of chlorinated solvents and install air sparging and soil vapor extraction wells for remediation pilot testing. Coordinated equipment procurement, shipping, and personnel logistics for team of environmental samplers and subcontractors. Managed drilling team to install four sets of air sparging and soil vapor extraction wells. Conducted pilot study, including air sampling, soil sampling, groundwater sampling, and groundwater response monitoring through slug testing and long-term transducer deployment.

Project Engineer, Monofill Permitting, Adak, AK. Supported inert waste monofill construction by providing onsite hazardous waste survey and assessment prior to building demolition. Helped steer safety planning onsite for asbestos mitigation and temporary cap construction. Assisted with preparation of the permit application, including creating the initial engineering design of the monofill.

JACOB BOUGERE, EIT**ENVIRONMENTAL ENGINEER**

Mr. Bougere is a Qualified Environmental Professional with two years of experience performing environmental site investigations and remedial actions, to include preparing planning documents, reports, and feasibility studies and conducting fieldwork. His field experience includes groundwater sampling, product recovery, surface water and porewater sampling, removal actions, subsurface and surface soil sampling (discrete, composite, and incremental sampling methodology [ISM]), sediment sampling, and monitoring well installation and development, and surveying. Jacob has remote/austere experience throughout Alaska in locations such as Swanson River Oil Field (SRF), Kenai Gas Field (KGF), Cannery Loop Unit Pad 3 (CLU3), and Beaver Creek Unit Pad 4 (BCU4) on the Kenai Peninsula, Chernofski Harbor on Unalaska Island, and Eareckson Air Station on Shemya Island. Jacob has two years of experience working on large- and small-scale projects for clients including Hilcorp, USACE, AFCEC, FAA, and USCG.

EDUCATION/QUALIFICATIONS

Total Cumulative Years: 2
Employer: ARS Aleut Remediation, LLC
Present Position/Title: Environmental Engineer
US Citizen: Yes
Education: B.S., Environmental Engineering, Louisiana State University, 2020

Certifications: Engineer-in-Training (EIT); ADEC-Qualified Environmental Professional
Relevant Training: OSHA HAZWOPER 40-hr Training and 8-hr refresher; OSHA HAZWOPER Supervisor 8-hr Training; USACE and NAVFAC Construction Quality Management Training for Contractors, DOT Hazmat Employee Training/IATA Dangerous Goods Shipping Training; Delayed Care First Aid/CPR/AED; Confined Space Entry Training

RELEVANT EXPERIENCE

Environmental Engineer/Field Sampler, Hilcorp Alaska, LLC, Contaminated Sites Long-Term Groundwater Monitoring Program, SRF Tank Settings (TS), SRF Electric Shop, KGF, BCU4, and CLU3, Kenai Peninsula, AK. Performed groundwater gauging, groundwater and surface water sampling, product recovery, monitoring well development, and monitoring well maintenance at seven TS units, one former tank area, and six pads across four sites on the Kenai Peninsula in support of bi-annual groundwater monitoring program. Over a three-week period, assisted with the gauging of 170 wells, groundwater sample collection at 98 wells, surface water sample collection at 20 locations, and product recovery at six wells. Reduced risk while undergoing unique safety challenges including operating near flare stacks, within marshlands, and near wildlife: coordinated with gas field lead operator and donned flame-retardant gear/proper PPE prior to entering flare pit; negotiated unstable ground and used gear such as floatation sleds while operating within marshland; remained cognizant of caribou, bears, and moose while conducting operations. Supported bi-annual monitoring program report. Supported production of the 2021 Groundwater Monitoring Program Report for SRF TS units and the 2021 Groundwater Monitoring Program Report for KGF.

Environmental Engineer, USACE Alaska, Removal Actions and Investigations, Chernofski Harbor Supply and Storage, Formerly Used Defense Site (FUDS), Unalaska, AK. Performed nine total weeks of removal action and investigation fieldwork at 111 project features within the remote Chernofski FUDS in the Aleutian Islands and was the field sample manager for two mobilizations with 750 total primary samples collected. Performed ISM soil sampling, discrete subsurface and surface soil sampling, sediment sampling, porewater sampling, monitoring well development and sampling, transducer installation and tidal influence evaluation, slug testing, guided excavations of petroleum, oil, and lubricant (POL) and/or lead-contaminated soil within and around areas with cultural resources, excavation confirmation soil sampling, and assisted with ultra-violet optical screening tool (UVOST) operations, direct-push soil borings, and monitoring well installations. During fieldwork, over 3,200 tons of contaminated soil, 1,203 linear feet of

fuel piping, one aboveground storage tank, and two underground storage tanks were removed, 253 UVOST probes and 199 soil borings were advanced, 24 monitoring wells and 13 temporary well points were installed. Lead author for the Removal Action and Investigation Report that totaled over 5,000 pages, including 104 figures, and supported production of the Site Visit Report and Removal Action and Investigation Work Plan.

Environmental Engineer, USACE Omaha, Former Lincoln Air Force Base Tank 27 Site Closure, Lincoln Municipal Airport, Lincoln, NE. Developed light non-aqueous phase liquid (LNAPL) manual skimming test standard operating procedure in accordance with the ASTM International Standard Guide for Estimation of LNAPL Transmissivity. Performed the manual skimming test on a monitoring well adjacent to an active airplane runway over a five-day period and analyzed results of test to determine transmissivity of the LNAPL formation at the site that was then used for site closure determination. Managed the manual skimming test activities as part of a two-person team. Authored a Work Plan Addendum that included a free product removal event, LNAPL transmissivity data collection, a year of quarterly gauging at four monitoring wells, well abandonment, and reporting. Prepared the Technical Memorandums for the free product recovery event, LNAPL transmissivity test, and quarterly gauging events. Authored the Site Closure Report, and the site was successfully closed following decommissioning of the monitoring wells and receipt of the No Further Action letter from the Nebraska Department of Environment and Energy.

Environmental Engineer/Field Sampler, USACE Alaska, Remedial Investigation and Feasibility Study, Nike Site Bay FUDS, Goose Bay, AK. Performed discrete surface and subsurface soil sampling, geotechnical soil sampling, soil characterization, field screening using a photoionization detector, ISM soil sampling, groundwater gauging, passive soil gas sampling, and monitoring well development throughout one feature of concern, four features of assessment, and 16 features of interest over the course of three mobilizations in support of remedial investigation. Collected 399 primary and 40 duplicate soil samples from split-spoons at 47 shallow soil borings, assisted with surveying, collected ISM soil samples, developed six newly installed monitoring wells, gauged six monitoring wells, and deployed three passive soil gas samplers. Maintained sample summary and produced chain of custody forms for sample delivery to analytical laboratory. Assisted with the development of the Work Plan, Remedial Investigation Report, and the Feasibility Study.

Environmental Engineer/Field Lead/Field Sampler, USCG Base Kodiak RCRA Long-Term Monitoring Site 1 Landfill, and Sites 3, 6A, and 7A, Base Kodiak, Kodiak Island, AK. Quarterly monitoring program for hazardous waste management units subject to RCRA corrective actions as part of a Post-Closure Plan. Performed as Field Lead for the October 2022 Q4 groundwater sampling, surface water sampling, and monitoring well inventory event. Performed as field sampler during the January 2021 Q1, April 2021 Q2, January 2022 Q1, and July 2022 Q3 events. Assisted with the collection of groundwater samples from up to 27 monitoring wells depending on the quarter, collected groundwater level and total well depth measurements, performed monitoring well maintenance and inventory activities, performed surface water and seep sampling, performed asphalt cap inspections, conducted a monitoring well inventory of 370 monitoring wells, and collected three differential pressure measurements and 11 flow rate measurements to inspect the vapor intrusion mitigation system in place.

Environmental Engineer/Field Sampler, FAA, Remedial Investigation and Groundwater Monitoring at the Former Radio Range Towers and Former Civil Aeronautics Administration Garage, Northway Field FAA Station, Northway, AK. Performed a Remedial Investigation at a former FAA facility. Assisted with the installation of 18 UVOST probes. Collected seven soil samples at varying depths from five soil borings. Assisted with the installation and construction of three groundwater monitoring wells. Developed three newly installed monitoring wells and assisted with the collection of groundwater samples from 18 existing monitoring wells and three newly installed monitoring wells at former FAA facilities.

Mr. Gingery has over 13 years of experience working on environmental projects in Alaska and abroad. He has extensive experience developing and implementing QA/QC programs, providing field support, and processing and managing analytical data. His experience includes work plan and technical report authoring, environmental sample collection, on-site mobile laboratory operations, bench chemistry, and data management. As a Project Chemist at ARS Aleut Remediation, LLC (Aleut), Nathaniel’s primary focus is chemistry support for various efforts conducted throughout Alaska and the Pacific Northwest. He also provides field support, conducting environmental sampling for a variety of media including groundwater. In addition to being an accomplished field team member for remote field efforts across Alaska, Nathaniel has developed, implemented, and supported digital data collection using ArcGIS Pro and Survey123. He has provided chemistry support for a variety of groundwater monitoring and other projects in accordance with State and Federal regulatory programs including ADEC Contaminated Sites Program, ADEC Solid Waste, RCRA, CERCLA, and CWA.

EDUCATION/QUALIFICATIONS

Total Cumulative Years: 13
Employer: ARS Aleut Remediation, LLC
Present Position/Title: Chemist
US Citizen: Yes
Education: B.S., Natural Science with a Minor in Chemistry, University of Alaska, Anchorage, 2017.

Certifications: ADEC-Qualified Environmental Professional
Relevant Training: OSHA 40-hr Hazardous Site Training (with annual 8-hour refresher); OSHA 30-hr Construction Safety and Health Training; OSHA Confined Spaces Training; DOT Hazardous Materials Transportation; IATA Dangerous Goods Transportation; First Aid/CPR/AED; UFP-QAPP training

RELEVANT EXPERIENCE

Project Chemist, Hilcorp Alaska Environmental Program Support, Kenai and Cook Inlet, AK. Provides environmental chemistry and data management support for Hilcorp’s Kenai and Cook Inlet oil and gas assets. Supports the management and validation of environmental data collected in support of environmental programs including ADEC Contaminated Sites monitoring, compliance, and remediation projects.

Project Chemist, Hilcorp North Slope Environmental Program Support, Prudhoe Bay, AK. Provides environmental chemistry support for Hilcorp’s upstream and midstream oil and gas assets. Supports the management and validation of environmental data collected in support of environmental programs including ADEC Contaminated Sites monitoring, compliance, and remediation projects.

Project Chemist/Field Sampler, Hilcorp Kenai Peninsula Waste Sites Groundwater Monitoring Program, SRF Grind and Inject Facility, Kenai Peninsula, AK. Conducted monitoring well inspections, groundwater gauging, and sampling activities. Supported chemistry elements for a long-term groundwater monitoring project at the Swanson River Grind & Inject Facility. Evaluated chemical data and prepared reporting documents for ADEC Solid Waste program review and approval. Designed and maintained digital data collection forms and an end use system for automated data flow from fieldwork to reporting.

Project Chemist/Field Sampler, Inert Waste Monofill Groundwater Monitoring, Adak, AK. Coordinated with the analytical laboratory to procure glassware. Conducted monitoring well inspections, groundwater gauging, and sampling activities. Designed and maintained digital data collection forms and an end use system for automated data flow from fieldwork to reporting. Evaluated chemical data and prepared reporting documents, including a data quality report, for ADEC Solid Waste program review and approval. Assisted in the collection of geospatial data and drone survey imagery.

Project Chemist/Field Sampler, Eareckson Air Station Landfill Groundwater Sampling Support, Eareckson, AK. Reviewed glassware orders and equipment inventory to ensure proper sampling supplies/equipment were available. Led and trained Eareckson-based field technicians in proper gauging, purging, and sampling methods. Conducted monitoring well inspections, groundwater gauging, and sampling activities. Performed sample management activities, including labeling, packing, shipping, and maintaining the chain-of-custody. Evaluated chemical data and prepared reporting documents, including a data quality report, for ADEC Solid Waste program review and approval.

Project Chemist, Joint Base Elmendorf-Richardson (JBER) ORC Remedial Investigation, JBER, AK. Reviewed and validated analytical chemistry data and generated report crosstabs. Managed databases of current and historical chemistry data and worked with GIS team to produce report figures. Developed digital data collection and storage and worked with GIS team to integrate data into an online dashboard. Worked with authoring teams to write environmental project work plans and reports. Coordinated with analytical laboratories to ensure the accurate and timely delivery of sample kits to meet project requirements. Served as site safety officer and sample team member for field efforts.

Project Chemist, JBER Fence-to-Fence Monitoring, JBER, AK. Served as field staff on F2F quarterly groundwater and soil gas monitoring efforts. Managed and shipped samples to lab. Performed data qualification and wrote data quality review for several quarters.

Project Chemist, King Salmon AFS Remedial Investigation, King Salmon, AK. Developed and supported digital data collection, storage, and export to report format. Worked with GIS team to ensure offsite project managers had a real-time picture of field progress. Planned, purchased, and mobilized field supplies and equipment. Worked as member of field team collecting soil, sediment, groundwater, and surface water samples. Installed and sampled sub-slab soil gas ports. Filled in as field team lead on multiple occasions, including overseeing subcontractors to ensure the final soil borings were completed at the end of the project.

Project Chemist, Eklutna Remedial Investigation/Risk Assessment, Eklutna, AK. Assisted in the installation of a sitewide electronic water level monitoring system and performed monthly readings for 13 consecutive months. Managed and shipped environmental samples to the lab. Collected passive soil gas and ambient air samples. Performed data quality assessment and wrote validation reports for both field mobilizations.

Project Chemist, Palau LRS Investigation. Worked with laboratory to ensure safe and IATA compliant sample transport in and out of Palau. Performed data quality assessment and wrote validation report.

Project Chemist, Eielson AFB PBR, Eielson, AK. Designed a data structure to handle decades of sample data and set up queries to generate report figures displaying targeted data.

Analytical Chemist, Multiple Project at SGS North America, Inc, Anchorage, AK. Responsible for conducting chemical analyses, maintaining instruments, and reporting accurate data for analytical methods including residential and industrial water quality suites, contaminated sites remediation testing, and compliance testing. Responsibilities included water quality sample analysis for drinking water methods, environmental sample extraction and analysis, and mobile laboratory operation.